



HFO10 Service Manual (HMI Controls)



Service Manual

\$50.00 USD

Manual Part Number 12A4171M20
(Revision 5/2026)

Important Safety Information



Any improper attempt to repair major equipment may result in personal injury, property damage, or loss of life. Before installing, operating, adjusting, or servicing the HFO10, please read this manual and become familiar with its contents, understand the operation of this machine, and be aware of possible dangers.

Safety Symbols and What They Mean

Heed the following safety symbols, which may appear in this manual and/or on the machine.

Symbol	Meaning
	Danger: Indicates an immediate hazard and that special precautions are necessary to avoid severe personal injury or death.
	Warning: Indicates a strong possibility of a hazard and that an unsafe practice could result in severe personal injury.
	Caution: Indicates that hazards or unsafe practices could result in personal injury or damage to product or property.

NOTICE

This manual belongs to the owner of the following Vogt Ice machine:

Model # _____ Serial # _____

This manual must remain on the premises with the above-listed machine at all times. After machine start-up, store the manual in a safe place where it can be readily available for future reference in maintaining, troubleshooting, or servicing the machine. Designate a person to be responsible for the manual.

Failure to comply with this notice will result in unnecessary inconvenience and possible additional expenses.

This manual is designed to assist with the installation, start-up, operation, maintenance, troubleshooting, and servicing of this equipment. This Tube-Ice® machine is designed to provide a lifetime of service when installed, maintained, and serviced properly.

This information is intended for use by individuals with adequate backgrounds in electrical, refrigeration, and mechanical expertise. Neither the manufacturer nor seller is responsible for the interpretation of this information, nor can they assume any liability in connection with its use.

If a situation calls for additional information not found in this manual, contact your distributor. If further assistance or information is needed, contact the factory by calling 1-502-635-3000 or faxing 1-502-635-3024.

Please read this manual carefully before attempting installation, operation, or servicing of this professionally designed piece of equipment.

The SuperCare group at Vogt Ice, LLC, provides assistance for all customer service needs, including part sales and warranty support. SuperCare also conducts training schools at the factory and can offer onsite training if needed.

The model and serial number of this Vogt equipment is located on the nameplate attached to the electrical control panel. If an electrical control panel was not furnished with this machine, the nameplate is located on the equipment frame or paneling. To enable SuperCare to handle your questions quickly and accurately, refer to the model and serial number when making inquiries about this machine.

Warranty Registration/Start-Up Form

The Warranty Registration/Start-Up Form on the next page must be completed and returned to Vogt Ice, LLC, within 2 weeks after the official start-up of the machine to initiate and ensure a full warranty. The form must be completed and either mailed to the address below, scanned and emailed to info@vogtice.com, or faxed to 1-800-770-8648. This form is also available online at www.vogtice.com/warrantyregistration/.

Please mail the completed form to:

Vogt Ice, LLC
1000 W. Ormsby Ave.
Suite 19
Louisville, KY 40210 USA

Vogt Ice, LLC 1000 W. Ormsby Ave, Ste. 19 Louisville, KY 40210 USA Phone: 502-635-3235 Fax: 502-635-3024		Vogt Order No.:	
		THIS FORM <u>MUST</u> BE SENT TO VOGT TO ACTIVATE WARRANTY	

Warranty Registration/Start-Up Form – Mid-Size Tube-Ice® Machines

Model Number:		Serial Number:	
---------------	--	----------------	--

This form must be filled out completely and signed by the customer in order to assure acceptance by Vogt.

Date of Start-Up:		Form Completed By:	
-------------------	--	--------------------	--

Distributor

Company Name:		Phone:	
---------------	--	--------	--

Address:		City:		State:		Zip:	
----------	--	-------	--	--------	--	------	--

Service Company

Company Name:		Phone:	
---------------	--	--------	--

Address:		City:		State:		Zip:	
----------	--	-------	--	--------	--	------	--

Customer (Location of Equipment)

Company Name:		Phone:	
---------------	--	--------	--

Address:		City:		State:		Zip:	
----------	--	-------	--	--------	--	------	--

PRE-OPERATION CHECK	OPERATION CHECK
----------------------------	------------------------

- Machine room suitable (50°F [10°C] min./110°F [43°C] max.)
 - Power Supply ___ V ___ Hz (machine not running)
 - Compressor crankcase heater on 12-hour minimum (packaged only)
 - All valves opened or closed as tagged
 - Solenoid valve stems in auto position
 - System checked for leaks and none found; all connections tight
 - Auxiliary equipment overloads wired into control circuit
 - Water supply and drains connected properly
 - Sufficient makeup water supplied (minimum 30 psig [2 bar])
 - Instruction manual and warranty certificate left onsite
- Name of person left with: _____

- Pump motor rotation direction correct
- Compressor motor rotation direction correct (packaged only)
- Power supply ___ V ___ Hz (machine running)
- Water pump amps RLA ___ Actual ___
- Condenser motor amps ___ (packaged only, if applicable)
- Incoming water temperature ___ °F (°C)
- Clear ice Yes No
- Suction pressure (psig [bar]): End of freeze ___
End of defrost ___ (packaged only)
- Discharge pressure (psig [bar]): End of freeze ___
End of defrost ___ (packaged only)

Comments:	

I certify that I have performed all the above procedures.

Technician Signature:		Customer Signature:	
-----------------------	--	---------------------	--

Table of Contents

HFO10 Mid-Size Ice Machine

Important Safety Information	3
<u>Safety Symbols and What They Mean</u>	3
NOTICE.....	4
Warranty Registration/Start-Up Form.....	4
Chapter 1 Introduction	1-1
Chapter 2 How the HFO10 Machine Works.....	2-1
Principles of Operation.....	2-1
Model Number	2-2
Piping.....	2-3
Freezing Period.....	2-6
Harvest Period.....	2-6
Refrigeration System Overview.....	2-7
<u>Charging Refrigeration Systems.....</u>	2-8
Chapter 3 Receipt of Machine.....	3-1
State of New Machine	3-1
Inspection	3-1
<u>Delivery Inspection Checklist.....</u>	3-1
Safety Tags and Labels.....	3-1
Pressure Relief Valves.....	3-1
Machine Location	3-2
Equipment Storage	3-2
Rated Capacity.....	3-2
Chapter 4 Installation of the HFO10	4-1
Machine Connections.....	4-1
Equipment Layout and Service Access	4-5
Lifting Procedures.....	4-6
Equipment Anchoring.....	4-7
Piping and Drain Connections	4-8
Water-Cooled Condenser Connections (Water-Cooled Machines Only).....	4-9
Cooling Tower (Water-Cooled Machines Only).....	4-9
Air-Cooled Condenser Connections (Air-Cooled Machines Only).....	4-10
Air-Cooled Condenser Installation Instructions.....	4-10
Air Cooled Condenser Wiring	4-16
Pressure Relief Valves.....	4-17
Wiring and Electrical Connections.....	4-17
Phase Check.....	4-18
Voltage Imbalance	4-18
Current Imbalance	4-19
Installation Checklist.....	4-20
Chapter 5 Start-Up, Shutdown, and Operation	5-1
Start-Up Checklist.....	5-1
Start-Up Procedure (Initial Start-Up).....	5-1

Shutdown Procedure.....	5-2
Start-Up and Shutdown Tips.....	5-2
Ice Quality.....	5-2
Adding Refrigerant.....	5-2
Chapter 6 Electrical Controls and Their Functions	6-1
Allen Bradley PLC with Touch Screen HMI	6-7
HMI Main Menu	6-7
HMI Primary Submenus.....	6-9
HMI Home Screen.....	6-14
HMI Detailed Screens	6-16
Control Panel Details	6-28
Chapter 7 Maintenance	7-1
Cleaning	7-1
Sanitizing.....	7-3
Water Distributors	7-5
Water Tank.....	7-6
Freezer Cover	7-6
Water-Cooled Condensers.....	7-6
Chemical Cleaning.....	7-7
Mechanical Cleaning.....	7-8
Compressor Lubrication	7-9
Lubrication of the Cutter Motor Gear Reducer	7-11
Preventive Maintenance	7-11
Daily Checklist.....	7-11
Weekly Checklist.....	7-12
Monthly or Yearly Checklist	7-12
Preventive Maintenance Form	7-13
Chapter 8 Troubleshooting	8-1
Machine Not Running.....	8-1
Freeze-Up from Extended Freeze Period	8-2
Freeze-Up from Ice Failing to Discharge.....	8-3
Poor Ice Quality	8-4
Low Ice Capacity	8-4
High Head Pressure (Water-Cooled Machines).....	8-5
High Head Pressure (Air-Cooled Machines)	8-6
Chapter 9 Servicing Operations	9-1
Adjustable Blowdown (for Clearer Ice).....	9-1
Automatic Blowdown	9-1
Makeup Water Float Valve	9-1
Refrigerant Float Switch	9-2
Hand Expansion Valve	9-3
Freezer Pressure Switch on Touch Screen HMI.....	9-3
Low Pressure Safety on Touch Screen HMI	9-3
High Pressure Safety on Touch Screen HMI	9-3
Head Pressure.....	9-3
Fan Cycling Pressure on Touch Screen HMI	9-3
Water-Regulating Valve (Water-Cooled Machines)	9-4
Cleaning Water-Cooled Condenser	9-4

Compressor Motor Protection 9-4

Compressor Motor Protection—Field Diagnosis..... 9-5

Compressor Motor Burnout 9-5

Oil Level Safety 9-6

Compressor Crankcase Heater (200 Watt)..... 9-6

Oil Separator..... 9-6

Control Circuit Protection..... 9-6

Thawing Timer 9-7

Pumpdown 9-7

Removing Refrigerant..... 9-10

Refrigerant Leaks 9-10

Non-Condensable Gases..... 9-10

Solenoid Valves..... 9-12

Capacity Control Valves 9-13

Circulating Water Pump Motor 9-14

Cutter Gear Reducer 9-14

Cutter Motor Replacement 9-15

Cutter Gear Reducer Removal and Replacement..... 9-15

Water Tank Removal 9-16

Cutter and Bearing Removal and Reinstallation..... 9-16

Crushed Ice Production 9-18

Appendix A Optional Accessories..... A-1

 Power Monitor, Wagner Model DTP-3..... A-1

 The Display A-1

 Adjustment of Parameters in Order of Display A-2

Appendix B Tables..... B-1

Appendix C Additional DocumentationC-1

Chapter 1 Introduction

Since Vogt introduced Tube-Ice® machines in 1938, the process of making Tube-Ice® ice has been widely recognized as the most economical means of ice production. These machines' economic and reliable operation has been proven repeatedly in a variety of installations throughout the world. The skill in engineering and fabrication Vogt Ice has learned in more than eight decades of experience is reflected in the HFO10 machine.

Using as little as one-third of the energy required by competing ice makers, Tube-Ice® machines produce the same amount of ice at great savings—in restaurants, sports arenas, packing plants, and wholesale operations around the world.

In addition, Tube-Ice® machines are renowned for their long service life, giving many customers more than 35 years of dependable service. Ask someone who owns one.

The HFO10 machine was introduced in 2017 as the next evolution of the Tube-Ice machine. It was developed to provide end users with a long-term synthetic refrigerant solution driven by a robust semi-hermetic screw compressor.

Hydrofluorocarbon (HFC) refrigerants are experiencing a phase-out in a variety of markets across the globe because of their high Global Warming Potential (GWP). This forces Original Equipment Manufacturers (OEMs) to build forward-thinking business strategies when selecting a replacement refrigerant for use in their equipment.

The challenge with implementing synthetic refrigerants in ice machines is to find the perfect balance between something that will work well in the application and be available for purchase for the foreseeable future. Finding this balance has been Vogt's focus.

Vogt's long-term refrigerant solution is HFO (hydrofluoroolefin) blends with similar properties as R134a. These HFO-based refrigerants have very low GWPs, which are in line with the European Union F-Gas Regulation phase-down and with projected refrigerant regulations in the United States.

In November 2017, at the International Packaged Ice Association convention, Vogt introduced the HFO10 machine. It is the first Tube-Ice machine designed to run on an HFO blend (R513A). This blend, along with other R134a-like HFO blends, is expected to be a long-term synthetic refrigerant solution. However, HFO blends are likely to be replaced by pure HFO refrigerants of the R1234-family. These pure HFOs will be retrofittable to the HFO10 machine, giving it a secure and well-defined future as the market evolves.

In addition to environmental benefits, the HFO10 machines operate at lower head pressures (approximately 130 psi or 9 bar), putting less overall stress on the system. Vogt uses Bitzer's innovative CSH semi-hermetic compact screw compressor, a robust design that is more reliable than a reciprocating compressor. A further benefit of the CSH compressor is that it produces less noise than the equivalent reciprocating design. The HFO10 has excellent energy efficiency, consuming as little as 2.68 kWh per 100 lb (45 kg) of ice produced.

The HFO10 machine is just the beginning of Vogt's new focus to innovate and introduce superior products to the marketplace.

Chapter 2 How the HFO10 Machine Works



Warning: Only service personnel experienced and certified in refrigeration and qualified to work with high-voltage electrical equipment should be allowed to install or work on this Tube-Ice® machine.

Principles of Operation

Chapter 2 Manual operation of the machine is controlled by the **Off**, **Ice**, and **Start** touch screen buttons on the **Home** screen of the HMI. These buttons appear on the default screen when power is supplied to the machine. Chapter 3 **Note:** Further references in this manual to the **Off**, **Ice**, **Start**, or **Run Water Pump** buttons are found on the **Home** screen of the HMI. See Chapter 6.

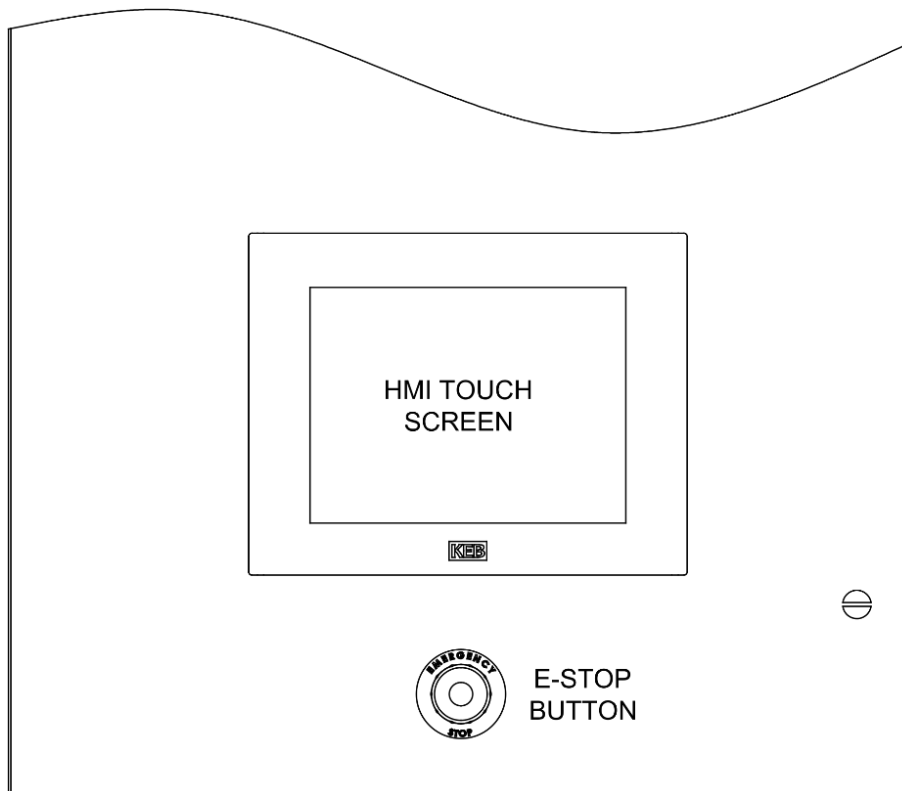

Figure 1: Control Panel Door

Automatic operation is controlled by the standard ice bin thermostats, which stop and start the ice maker based on the level of ice in the storage bin.

The type of ice produced, cylinder or crushed (optional), is determined by how the machine cutter is set up.

The unit will only stop when a thawing (harvest) period has been completed, whether by the pressing the **Off** touch screen button or the ice bin thermostat. To stop the machine instantly, push the **E-Stop** button. To restart the machine, turn the **E-Stop** button clockwise, clear the **E-Stop** fault on the touch screen, and push the **Start** touch screen button.

Air-cooled machines have a solenoid valve, sometimes referred to as the X valve, in the compressor discharge line and a check valve in the liquid return line to the receiver. These valves prevent the migration of refrigerant when the machine is not operating. The X valve is always open when the compressor is running.

Model Number

The machine nameplate is located on the left side of the control panel. The model number and machine description are located in the top left-hand corner. Figure 2 can be used to verify that the correct model has been received.

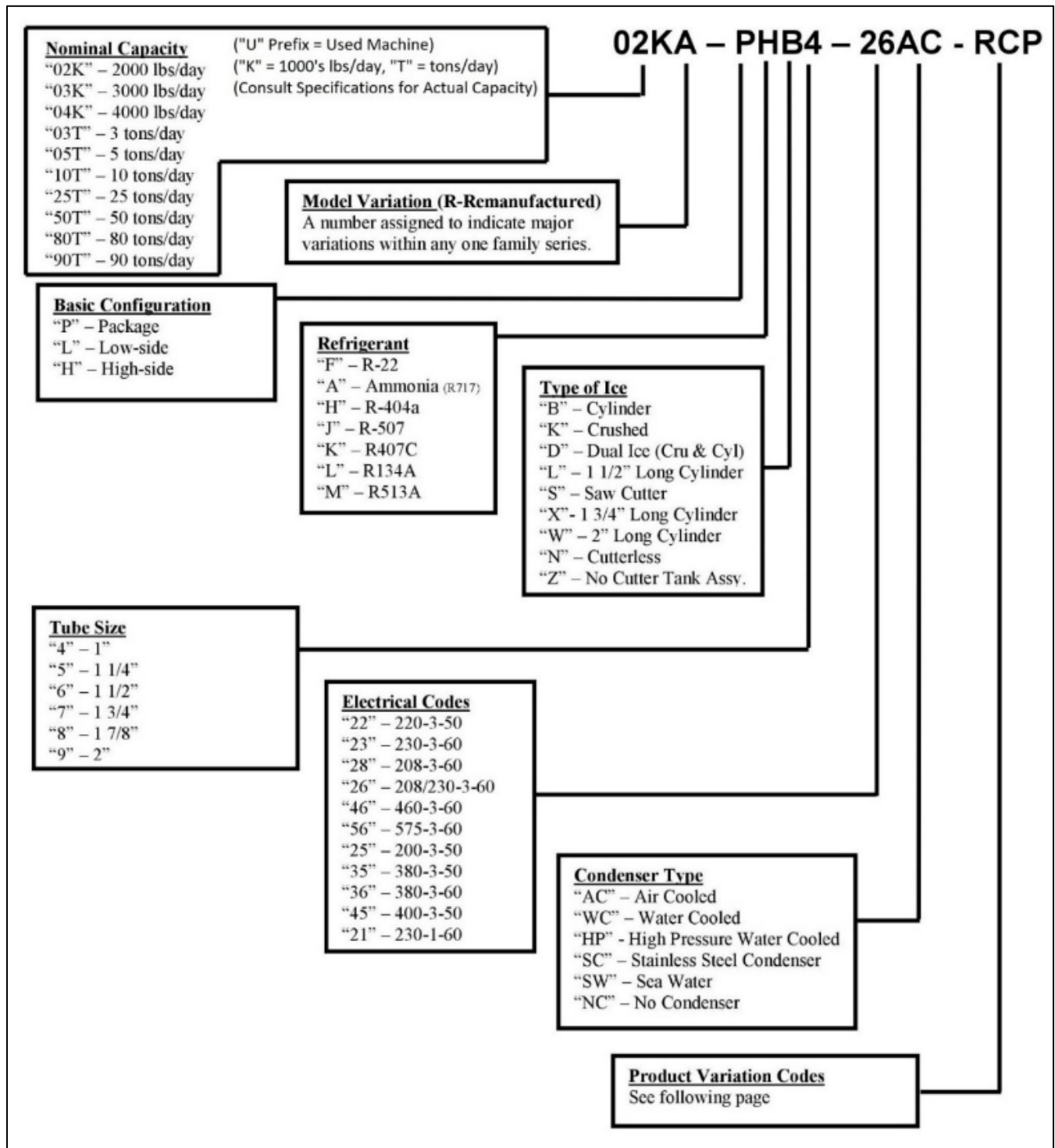

Figure 2: Vogt Model Nomenclature

Piping

Table 1 lists the piping nomenclature as labeled in Figure 3 and Figure 4, which illustrate the piping schematics of the refrigerant and water circuits of water- and air-cooled Tube-Ice® machines.

Table 1: HFO10 Piping Nomenclature

	Description		Description
1	Control Panel	32	A/C Condenser Service Connection
1PG	Suction Pressure Gauge	34	Compressor Suction Service Valve
2PG	Discharge Pressure Gauge	35	Compressor Discharge Service Valve
2	Freezer	37	Oil Charging/Drain Valve
3	Compressor	39	Water Tank Drain Valve
4PS	Dual High/Low Pressure Switch	40	Automatic Water Tank Blowdown
5M	Cutter Motor	41	Condenser Water Regulator (W/C Machines)
5R	Gear Reducer	41A	Condenser Pressure Control (A/C Machines)
6	Water Pump	43	Strainer
7	Water Tank (includes cutter assembly)	44	Receiver Drain Valve
8	Water Distributing Chamber	46	Filter Dryer
12	Makeup Water Float Valve	48	Muffler
13	Heat Exchanger	50	Receiver Safety Valve
15	Condenser	51	Freezer Safety Valve
15R	Receiver	52	Water Regulating Stop Valve (Water-Cooled Only)
16	Thawing Chamber	53	Cold Weather Solenoid Valve "X" (A/C Machines)
17	Expansion Valve	55	Discharge Line Stop Valve For A/C Machines
18	Thaw Gas Solenoid Valve (D)	56	Freezer/Pressure Switch
18S	Thawing Gas Pressure Switch	58	Liquid Outlet Valve (King Valve)
20	Liquid Line Solenoid Valve (A)	59	Receiver Purge Valve
22	Float Switch	69	Freezer Pressure Stop Valve
23	Condenser Water Inlet W/C Machines	70	Oil Return Stop Valve
23A	Makeup Water Inlet 3/4 FPT	88	Accumulator/Heat Exchanger
24	Condenser Water Outlet (W/C Machines)	90	Thawing Gas Stop Valve
25	Water Tank Drain Connection 1-in. FPT	91	Receiver Liquid Return Stop Valve
28	Refrigerant Charging Valve	94	Compressor Oil Pressure Safety Control
30	Receiver Sight Glass	101	Check Valve
31	Gauge Glass Stop Valve		

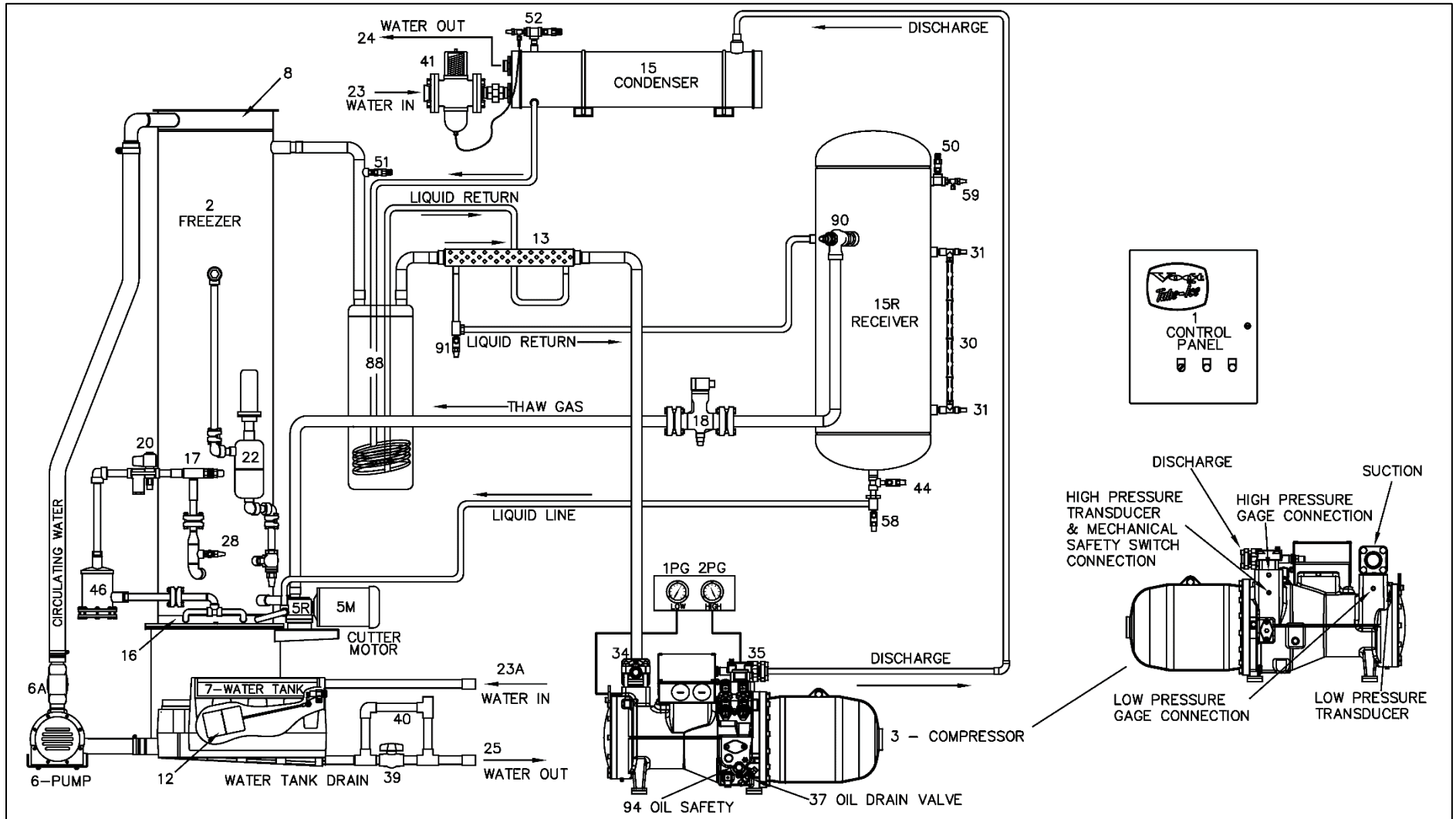

Figure 3: Water-Cooled Piping Schematic

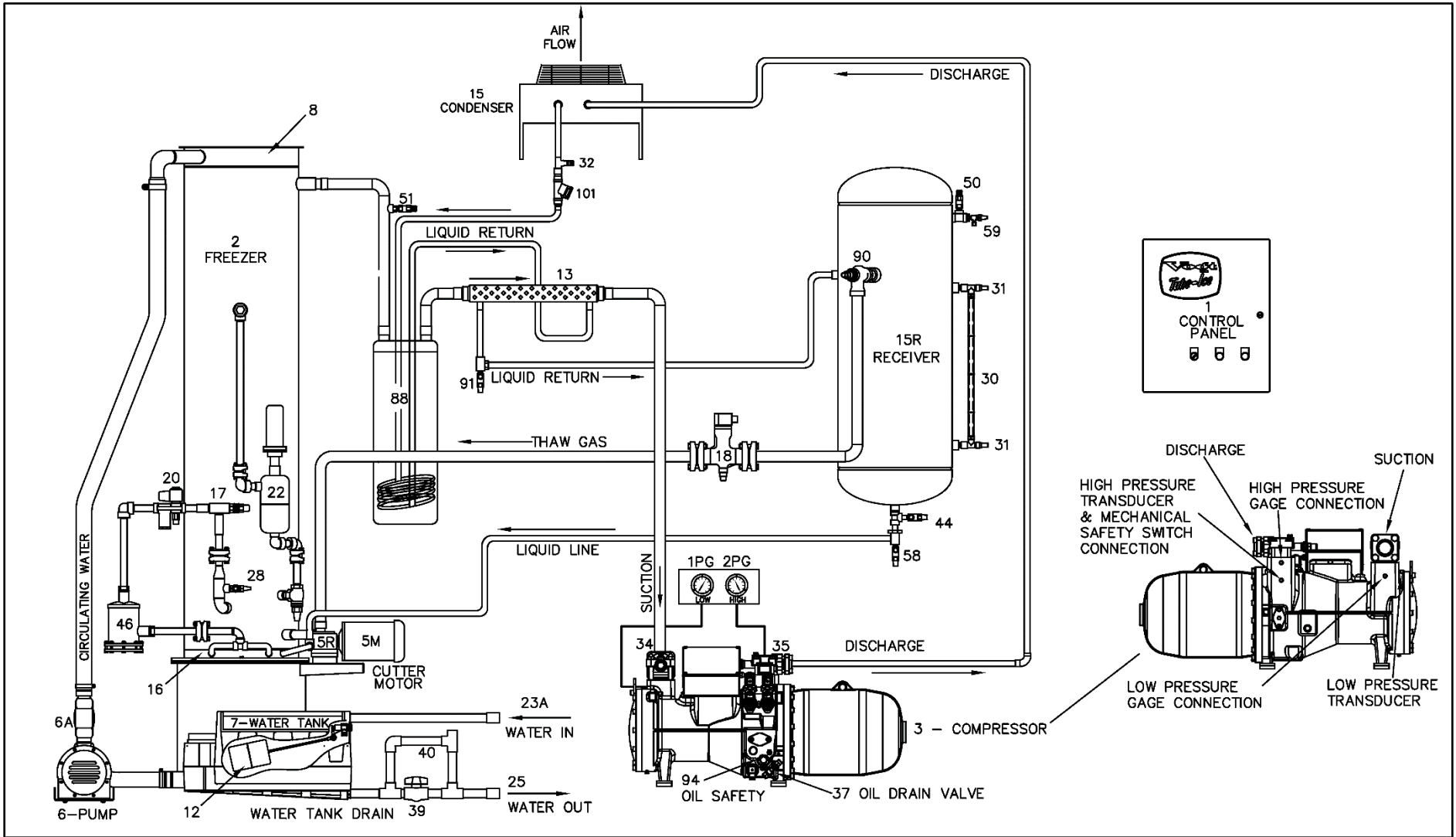

Figure 4: Air-Cooled Piping Schematic

Freezing Period

The freezer is a shell-and-tube type vessel, consisting of an outside shell with vertical tubes inside. Water freezes inside the tubes by the direct application of refrigerant to the shell side (outside) of the tubes. Ice is produced as the water continues to recirculate. As the ice thickens, the freezer suction pressure decreases. The **Freezer Pressure Switch** automatically initiates the thawing, or harvest, period as the freezer pressure reaches the setpoint in the PLC. Refer to *Freezer Pressure Switch on Touch Screen HMI*.

During the freezing period:

1. Water is constantly recirculated through the freezer tubes by a centrifugal pump.
2. Makeup water is maintained at the appropriate level by a float valve in the water tank.
3. A liquid line solenoid valve (A) is open, and a thaw gas solenoid valve (D) is closed.
4. Refrigerant gas from the top of the freezer passes through the suction accumulator, the heat exchanger, and the compressor.
5. The cool gas is compressed to a high-temperature, high-pressure gas that discharges through the oil separator and into the condenser.
6. In the condenser, heat is removed, and the gas is condensed to a high-temperature, high-pressure liquid.
7. This high-pressure liquid goes through the accumulator boil-out coil and suction line heat exchanger, where it gives up heat to the suction gas for compressor protection.
8. This liquid is subcooled and carried to the receiver.
9. Condensed liquid refrigerant from the receiver flows through the thawing chamber of the freezer, the filter/dryer, the liquid line solenoid valve (A), and then the expansion valve and capillary.
10. At the expansion valve and capillary feed, the refrigerant expands from a saturated liquid state of relatively high pressure to a very low-pressure, low-temperature liquid.
11. The float switch is wired to the liquid line solenoid valve (A).
12. The float switch energizes and de-energizes the liquid line solenoid valve (A) in response to the level of refrigerant in the freezer.
13. The cold liquid refrigerant enters the freezer, where it absorbs heat from the circulating water.
14. This cool gas is pulled out of the freezer at the suction outlet, thereby completing the circuit.

The freezing period is completed by the freezer pressure switch (FPS) in the Vogt 450 controller.

1. The water pump stops, and the liquid line solenoid valve (A) closes.
2. The thawing (harvest) period begins.

Harvest Period

During the harvest period:

1. The PLC stops the water pump, closes the liquid line solenoid valve (A) and starts the **Harvest Timer**.
2. The cutter motor starts after an adjustable **Cutter Delay** and the thaw gas solenoid valve (D) opens after an adjustable **Thaw Gas Valve Delay**.
3. The adjustable Thaw Gas Valve setpoints stored in the PLC open and close the thaw gas solenoid valve (D) valve to maintain the proper pressure for ice to release without adding unnecessary heat.
4. Warm gas from the receiver is discharged into the freezer through the valve, and the outer edge of the ice slightly thaws for sizing by the rotating cutter.
5. As the ice releases and drops through the rotating cutter and onto the cutter disc, it discharges through the side opening of the water tank.
6. The **Harvest Timer** is set for the time required to discharge all the ice plus 30 seconds (can be up to 5 minutes).

CAUTION

To prevent refreezing, make sure all ice clears the freezer with at least 30 seconds to spare before the next freezing period begins.

Refrigeration System Overview

The refrigeration system uses hydrofluoroolefin (HFO) blend refrigerant R513A.

It contains:

- Bitzer semi-hermetic compact screw compressor (CSH) with integral oil separator
- Refrigerant float switch
- Expansion valve
- Flooded evaporator (freezer)
- Hot gas defrost

As shown in the piping schematic, the compressor discharge gas leaves the compressor and goes into the condenser. Here, the gas is condensed into liquid as heat is removed from the water as it passes through the condenser during the freezing period.

A reservoir of liquid is accumulated in the receiver and flows as required, passing through the thawing chamber (located in the lower section of the freezer) then through the filter/dryer. The liquid line solenoid valve (A) opens and closes in response to the liquid level in the freezer, as determined by the refrigerant float switch mounted on the side of the freezer.

Liquid refrigerant floods the evaporator and comes in contact with the outside of the ice-making tubes through which water is being circulated. The heat contained in this water passes through the walls of the tubes, lowering the temperature of the water, causing it to freeze and to form a long tube of ice that adheres to the inside of each freezer tube. Since the purest water freezes first, the flowing water keeps the accumulated ice clear by washing separated solids down into the sump area of the water tank. The blowdown valve on the circulating water pump discharge helps to rid the water tank of increased dissolved solids found in harder water by flushing them out of the overflow during water pump operation.

During the harvest period, the water pump stops, therefore, all the water circulating in the freezer drops to the tank, the tank level increases, and the overflow will get rid of that extra water. The overflow is a hole at the top of the tank. Refer to Chapter 9 for more information about automatic blowdown.

The transfer of heat from the water to the liquid refrigerant causes it to boil and convert into a liquid-vapor mixture at the suction connection at the top of the freezer. This liquid-vapor mixture passes through the suction accumulator, where liquid droplets are removed and boiled off from the internal heating coil. The suction line heat exchanger boils off any residual droplets that may have passed through the suction accumulator, providing ample protection for the screw compressor.

As the ice forms in the freezer tubes, the suction pressure steadily decreases until it causes the freezer pressure switch (FPS) to close, initiating the harvest period.

During the harvest period, the thaw gas solenoid valve (D) is open, allowing warm high-pressure gas from the receiver to enter the freezer. This heat melts a thin film from the outside of the ice, reducing the outside diameter slightly, allowing it to fall free from the freezer tubes. This period lasts approximately 2-1/2 minutes.

Note: Freezing times will vary, depending on makeup water temperature and setting of the freezer pressure switch. As you become more familiar with the operation of your machine, you will be able to recognize and correct minor irregularities as they occur, which will help prevent major problems.

Charging Refrigeration Systems

CAUTION

Only technically qualified persons, experienced and knowledgeable in the handling of refrigerant and operation of refrigeration systems, should perform the operations described in this manual.

All local, federal, and EPA regulations must be strictly adhered to when handling refrigerants. If a refrigeration system is being charged from refrigerant cylinders, disconnect each cylinder when empty or when the system is fully charged.

Included with the machine is the required charge of R513A refrigerant (approximately 470 lb [213 kg]), isolated in the receiver. Before shipment of the machine, the compressor service valves and the stop valves in the various lines to the condenser and receiver were closed. These valves are tagged with instructions to be opened before start-up of the machine.

Before opening these valves, check all joints for leaks that may have developed during shipment. If no leaks are present, a positive pressure should show on the suction and discharge pressure gauges. They should indicate a pressure approximately equal to the ambient temperature, which can be found using the pressure temperature chart.

A gauge should be installed in the charging line to indicate refrigerant cylinder pressure. The cylinder may be considered empty of liquid refrigerant when the gauge pressure is 25 psig (1.7 bar) or less, and there is no frost on the cylinder. Close the refrigerant charging valve and cylinder valve before disconnecting the cylinder. Loosen the union in the refrigerant charging line carefully to avoid unnecessary release of refrigerant into the atmosphere. Refer to local and national regulations.

CAUTION

Immediately close the system charging valve at the commencement of the defrost or thawing cycle if a refrigerant cylinder is connected. Never leave a refrigerant cylinder connected to the system except during charging operation. Failure to observe either of these precautions can result in transferring refrigerant from the system to the refrigerant cylinder, over-filling it, and possibly causing the cylinder to rupture because of pressure from expansion of the liquid refrigerant.

CAUTION

It is not recommended that refrigerant be transferred from a refrigeration system directly into a cylinder. If such a transfer is made, the refrigerant cylinder must be an approved, clean cylinder that is free of any contaminants or foreign materials. The cylinder must be connected to an approved recovery mechanism with a safety shutoff sensor to ensure that contents do not exceed the net weight specified by the cylinder manufacturer or any applicable code requirements.

Chapter 3 Receipt of Machine

CAUTION

Only service personnel experienced in refrigeration and qualified to work with high-voltage electrical equipment should install or work on this machine. Eye protection must be worn by all personnel working on or around the machine. You must be familiar with and adhere to all local ordinances and laws regarding the handling, storing, and use of refrigerants. Refer to the safety data sheet.

State of New Machine

The HFO10 is a packaged ice-making machine, either water-cooled or air-cooled, complete with compressor, oil separator (integral to compressor), receiver, and condenser (if water-cooled). The machine was shipped in a fully pumped down state with all refrigerant stored and isolated in the receiver. All valves on the machine are tagged as to their state (open or closed) and their purpose. The machine was cleaned with ice machine cleaner and flushed so that it is ready for ice production.

Inspection

Upon receipt of the Tube-Ice® machine, inspect it for any obvious damage. If damage is found or suspected, note it on the trucker's Bill of Lading. Immediately submit a separate written request for inspection by the freight line's agent. Any repair work or alteration to the machine without the permission of Vogt Ice, LLC, can void the machine's warranty. Also, notify your Vogt distributor or the factory.

Delivery Inspection Checklist

- Inspect outer casings (if provided)
- Inspect piping and valves
- Inspect refrigerant sight glass for damage

The machine was shipped with a full refrigerant charge stored and isolated in the receiver. Visually check all lines for mechanical damage. If a leak is suspected, check all joints with a refrigerant leak detector supporting HFO blend refrigerants. All leaks should be reported to Vogt Ice, LLC, to obtain authorization and instructions for repair.

The machine is factory tested before shipment and supplied with a Certificate of Test report confirming the conditions under which it operated at the factory and that the machine operated as designed. Minor adjustment may be required at the installation site to achieve optimal performance.

Safety Tags and Labels

Be sure to read and adhere to all special tags and labels attached to valves or applied to various areas of the machine. They provide important information necessary for safe and efficient operation of your equipment. The unit may have valves in the open or closed position and may be tagged with information about the required position for start-up.

Pressure Relief Valves

Pressure relief valves are included on this packaged Tube-Ice® machine. One is located on the freezer (low-side), one is located on the top of the condenser (high-side), and a third is located on the top of the receiver (high-side). Vent each of the pressure relief valves to the atmosphere in compliance with local and national codes.



Failure to do so creates a safety hazard that could cause injury or loss of life.

Machine Location

The machine must be located inside a suitable building and must not be subjected to ambient temperatures below 50°F (10°C) or above 110°F (43°C). Heat from other sources, such as sunlight, furnaces, condensers, or unusual air currents (including fans or air-conditioning air flow) may affect the operation of the machine and should be avoided. The electrical components of the Tube-Ice® machine are rated NEMA 1 or IP10. As such, the machine should not be located in a hazardous area or sprayed with water. The machine should be installed on a drainable condensate drip pan or in an area where there is no possibility of standing water, but readily drain away from the machine.

Equipment Storage

If the equipment must be stored before installation, it should be indoors and protected from extreme temperatures and high humidity. These conditions can deteriorate the various components used in the manufacture and assembly of the equipment.

CAUTION

This equipment contains the HFO refrigerant blend R513A under pressure. Do not store in an area exposed to temperatures above 115°F (46°C) or in direct sunlight at temperatures above 105°F (40°C).

Rated Capacity

This machine is rated to produce a given amount of ice when operating under the proper conditions as specified in this manual. Be prepared to handle the ice produced as it is discharged from the machine and move it to the storage or bagging area promptly.

Installation of the HFO10

Machine Connections



Warning: Only service personnel experienced and certified in refrigeration and qualified to work with high voltage electrical equipment are allowed to install or work on this Tube-Ice® machine.

Preparing the machine for operation requires connecting the following to the appropriate locations on the machine:

- Electrical supply
- Makeup water supply
- Water blowdown drain
- Condenser water inlet and outlet

The diagrams on the following pages show the basic connection locations and orientation of the HFO10 machine.

4-2

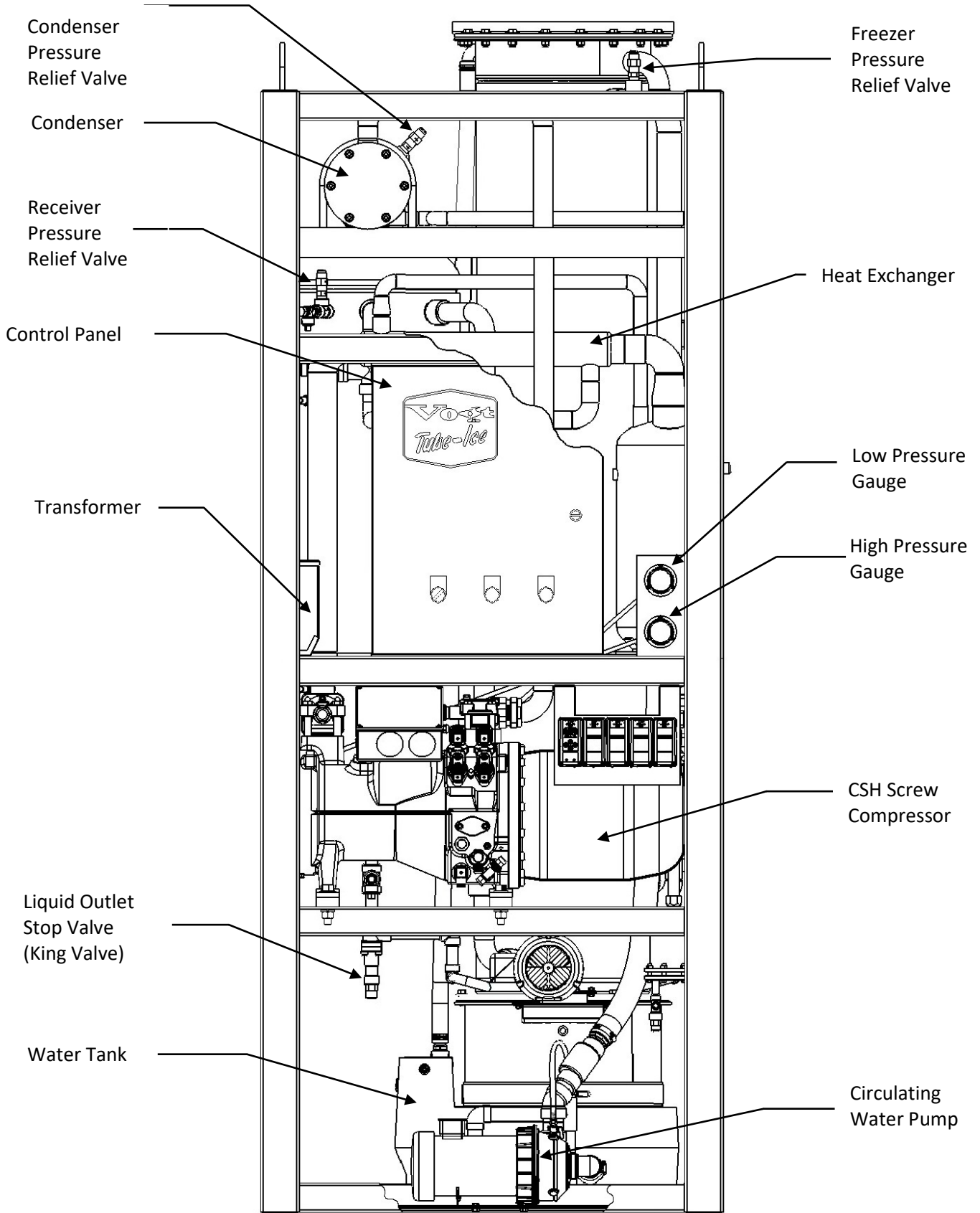

Figure 5: HFO10 Assembly Front View

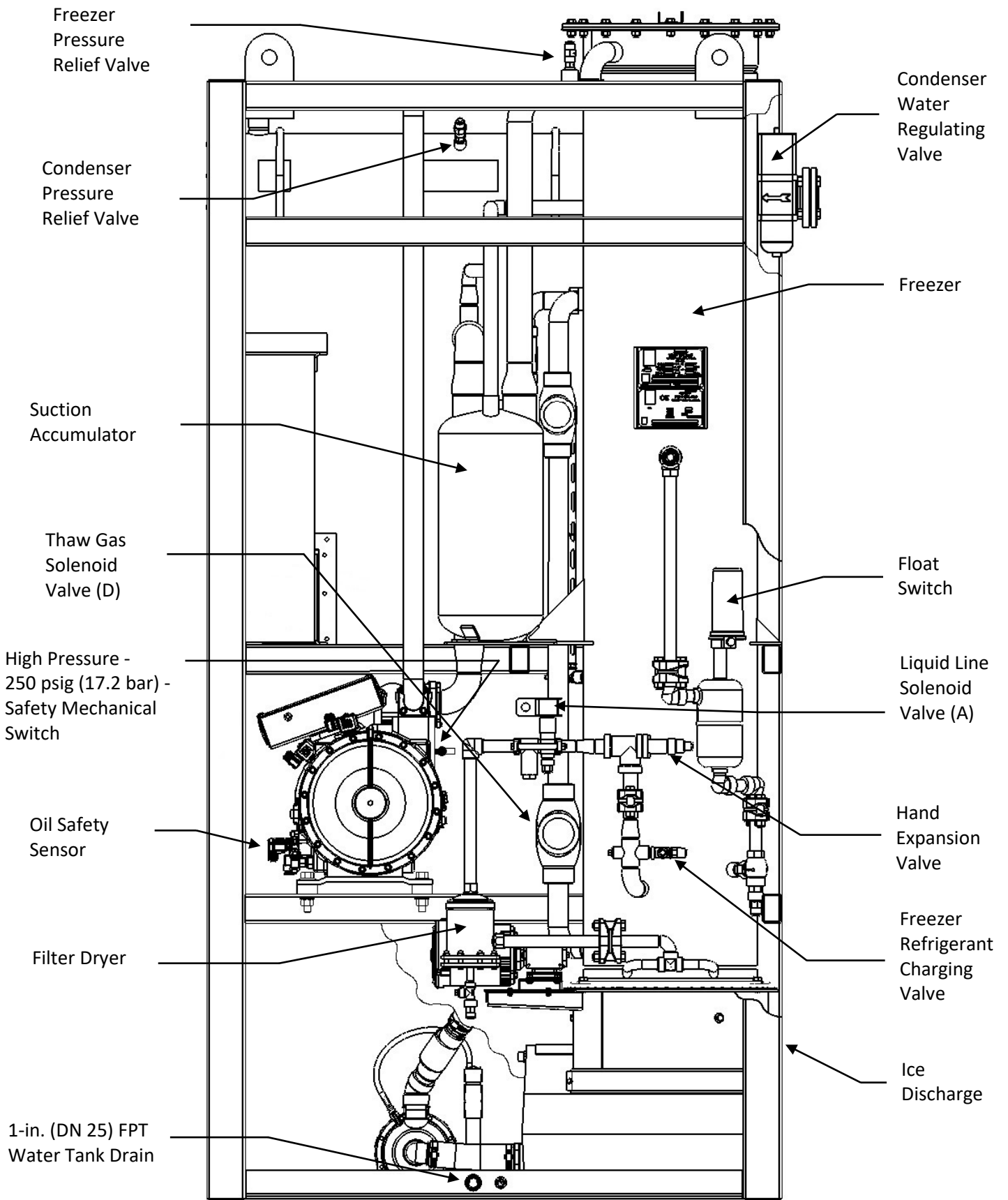

Figure 6: HFO10 Assembly Right Side View

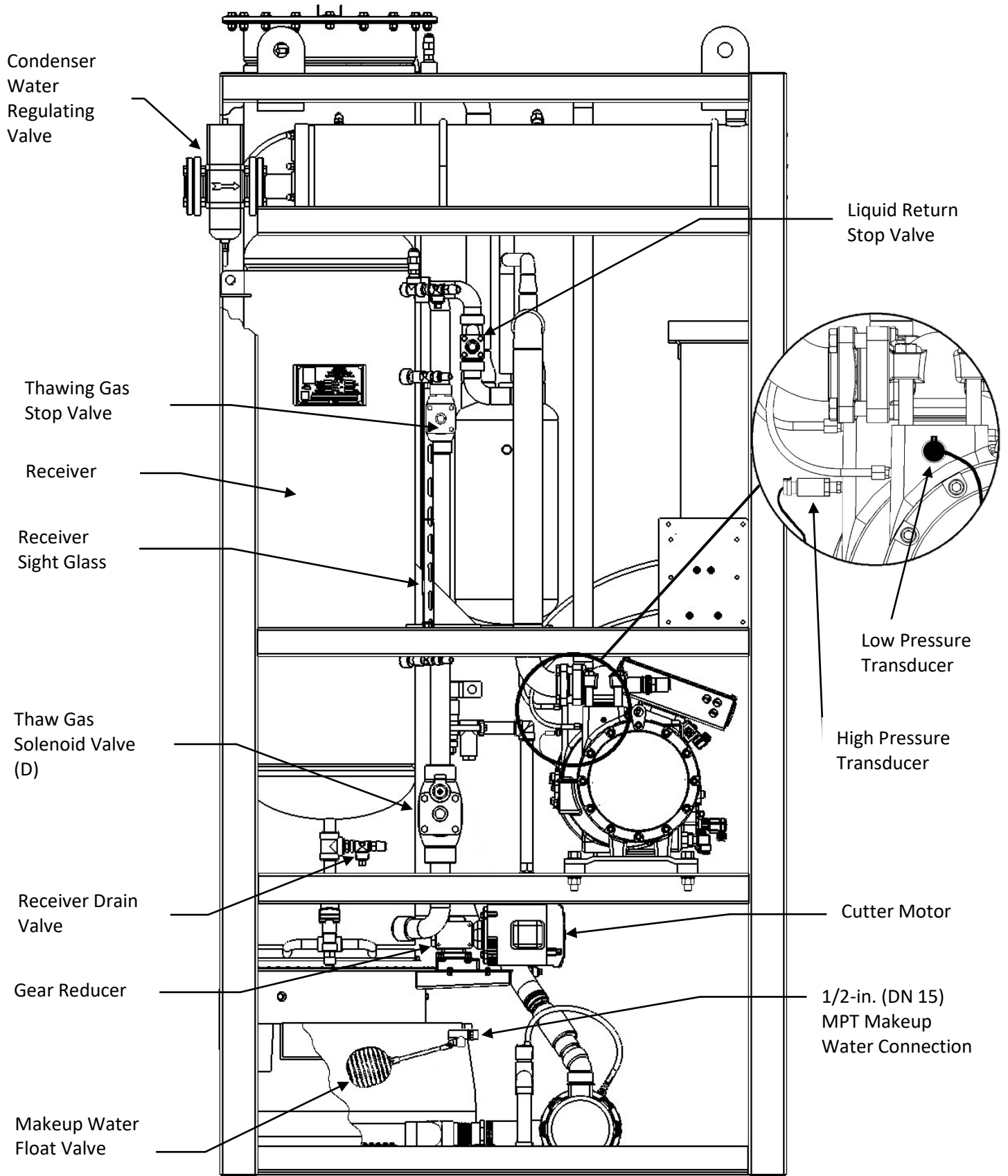

Figure 7: HFO10 Assembly Left Side View

Equipment Layout and Service Access

CAUTION

The approximate operating weight for the HFO10 is 5,200 lb (2,359 kg). The HFO10 requires certain clearances around the unit for safety reasons and to provide access for servicing operations. Figure 8 shows clearance requirements.

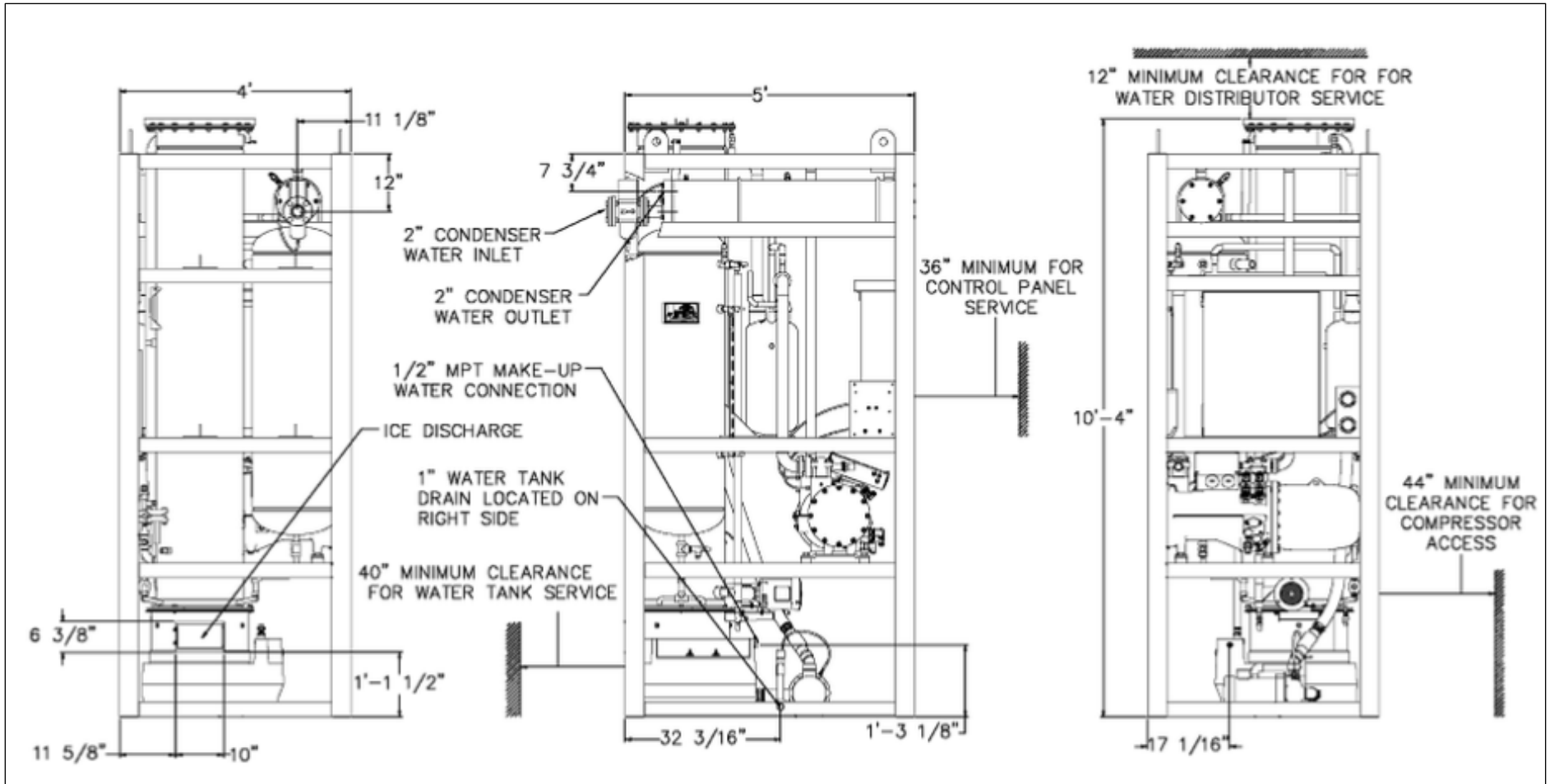

Figure 8: Connections and Clearance Diagram (Water-Cooled Machine)

Lifting Procedures



Warning: The machine weighs approximately 5,200 lb (2,359 kg). Use only the appropriate equipment with adequate loading capacity to move and install the machine.

The Tube-Ice® machine is top-heavy. The machine needs to be bound in place to prevent tipping.

Lift only from the top to avoid tipping. The machine frame has lifting lugs at each top corner for screw pin anchor shackle/eyebolt and hook to be used for lifting purposes. The lifting lugs should be used wherever possible.

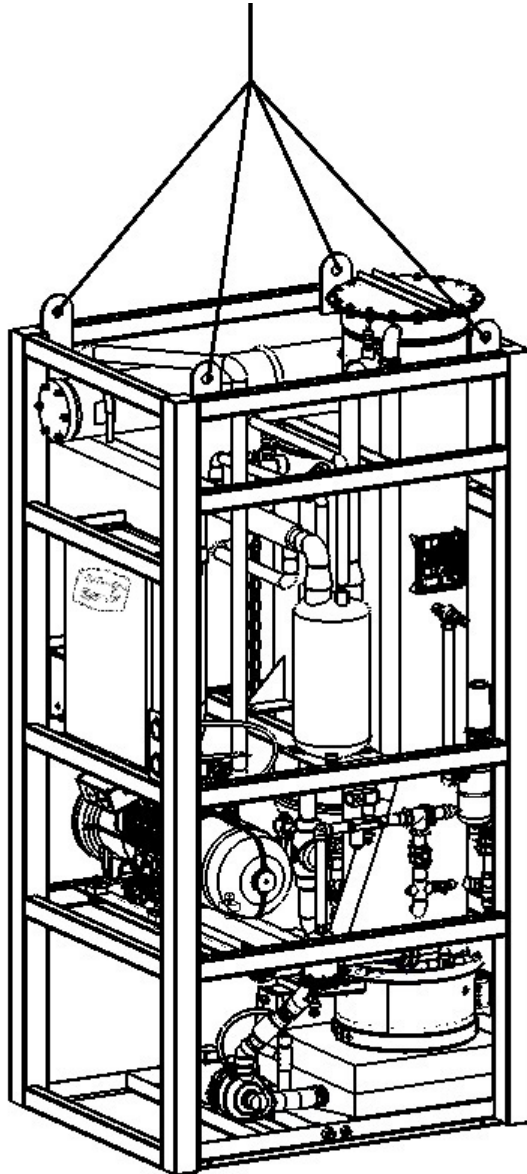

Figure 9: HFO10 Lifting Diagram

If a forklift is used, make sure its capacity is sufficient. The forks must be wide enough apart to prevent tipping sideways and must extend beyond the extremities of the ice machine frame. Do not lift the machine using the drain pan as a support.

Equipment Anchoring

The supporting foundation should be constructed from concrete or similar material in accordance with all local and federal codes and building regulations. Figure 10 indicates anchor bolt hole locations in the bottom frame of this Tube-Ice® machine. Consult local codes and regulations regarding seismic and wind load requirements. Additional bracing may be required.

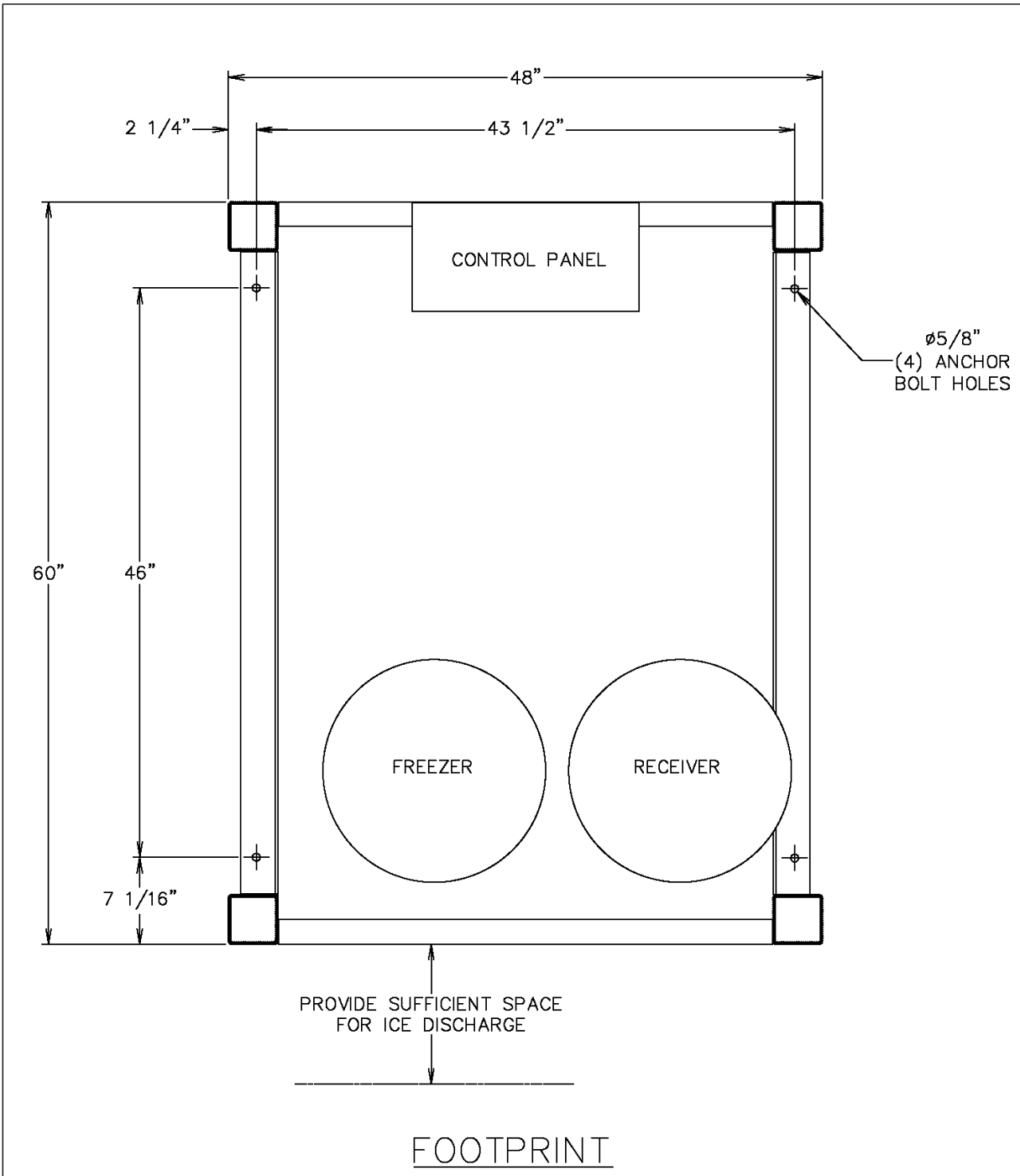

Figure 10: HFO10 Anchor Points

Piping and Drain Connections

CAUTION

External shut-off valves must be installed in the water inlet lines. The minimum inlet water pressure for satisfactory operation of the machine is 30 psig (2 bar). The maximum allowable pressure is 90 psig (6.2 bar).

Figure 5 to Figure 7 show locations for all connections. Table 2 shows drain sizes.

Table 2: Water Supply and Drain Sizes

Makeup Water In	Water Tank Drain	Condenser Water In	Condenser Water Out
1/2 in. (DN 15) MPT	1 in. (DN 25) FPT	2 in. (DN 50) FPT	<ul style="list-style-type: none"> • 2-1/2 in. (DN 65) FPT (Non-Europe) • 2-1/2 in (DN 65) BSPP (Europe)

The condenser water outlet and water tank drain connections must be extended to an open drain or sump, arranged for visible discharge. Do not allow water to be trapped in the water tank drain line, because this will interfere with the operation of the automatic blowdown system.

CAUTION

Do not connect these lines into a pressure-tight common header because warm condenser water may back up into the water tank. The condenser water outlet must be piped separately to the drain. Due to variations in water quality by geographic location, water filtering or treatment may be required to reduce maintenance and inhibit hardness buildup on machine components, such as freezer tubes and water valves.

Water-Cooled Condenser Connections (Water-Cooled Machines Only)

The water regulating valve is not installed on the condenser when it is shipped from the factory. Install the regulating valve on the condenser water inlet connection (bottom connection on condenser). Connect the condenser water outlet line to the top connection on the condenser.

Condenser Water Outlet

- 2-1/2 in. (DN 65) FPT
(non-Europe)

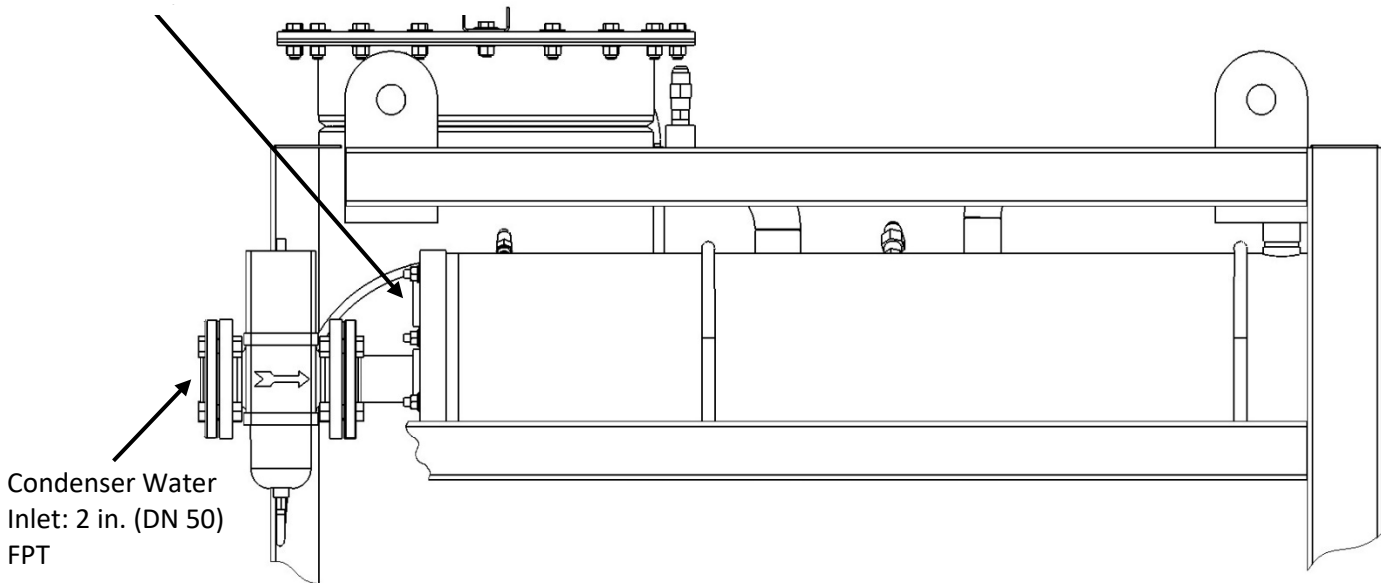

Figure 11: Water-Cooled Condenser Connections

Cooling Tower (Water-Cooled Machines Only)

When selecting a cooling tower, pay careful attention to operating wet bulb conditions. Check with your local cooling tower distributor for their recommendations based on actual operating conditions in your area. An average wet bulb temperature of 78°F (25°C) is typical in the United States, but many localities have design wet bulb temperatures as low as 72°F (22°C) or as high as 82°F (28°C).

The cooling tower water pump must be capable of delivering the required volume of water through the condenser. The pump must be sized for each installation, which depends on cooling tower location, pressure drop through water lines, and water regulating valves. The water piping for the cooling tower and the installation of the pump must be in accordance with the manufacturer's instructions.

Proper water treatment for the prevention of mineral and foreign matter accumulation in the condenser or cooling tower is recommended. A water analysis by an independent laboratory should be completed to determine the proper chemicals to use.

Air-Cooled Condenser Connections (Air-Cooled Machines Only)

Follow these procedures to make a tight joint:

1. Silver solder or braze condenser tubing ends to the female Rota-lock connectors.
2. Remove dust caps, if used, making sure that component plastic seals are intact.
3. Wipe off connector and spud threaded surfaces with a clean cloth to prevent the inclusion of dirt or any foreign material in the system.
4. Connector coupling nut should be screwed onto Rota-lock spud using the proper amount of torque. Table 3 shows torque ratings for Rota-lock connectors.

Table 3: Rota-lock Connector Torque Ratings

Spud Size	Torque
7/8 in.	50-60 ft-lb (68-81 N-m)
1-1/8 in.	80-100 ft-lb (108-136 N-m)
1-3/8 in.	100-110 ft-lb (136-149 N-m)

Air-Cooled Condenser Installation Instructions



Warning: These installation guidelines must be followed to obtain reliable operation from air cooled ice machines. If these guidelines are not followed, the compressor warranty will not be honored.

1. Use only Vogt approved condensers. Any exceptions to this policy must be obtained in writing from Vogt prior to installation and operation of the ice machines.
2. Outdoor condensers must be installed with vertical air flow. Indoor condensers used for heat recovery may be installed with either horizontal or vertical air flow.

Note: The condenser must be ordered for horizontal air flow.

3. The condenser must be mounted above the ice machine.
4. Horizontal runs in the liquid return line should slope 1/4 in./ft. (1.2°) with liquid refrigerant draining freely in the direction of normal operating flow (back to the ice machine) with no traps in the liquid line.
5. Horizontal runs in the discharge line should slope 1/4 in./ft. (1.2°) in the normal direction of flow (away from the ice machine).
6. Traps must be installed in discharge lines at the base of all vertical risers. There should be no intentional traps in liquid lines. Trap volume should be kept to a minimum. Long vertical rises should have traps every 20 ft. (6 m). Figure 1 shows typical trap details.

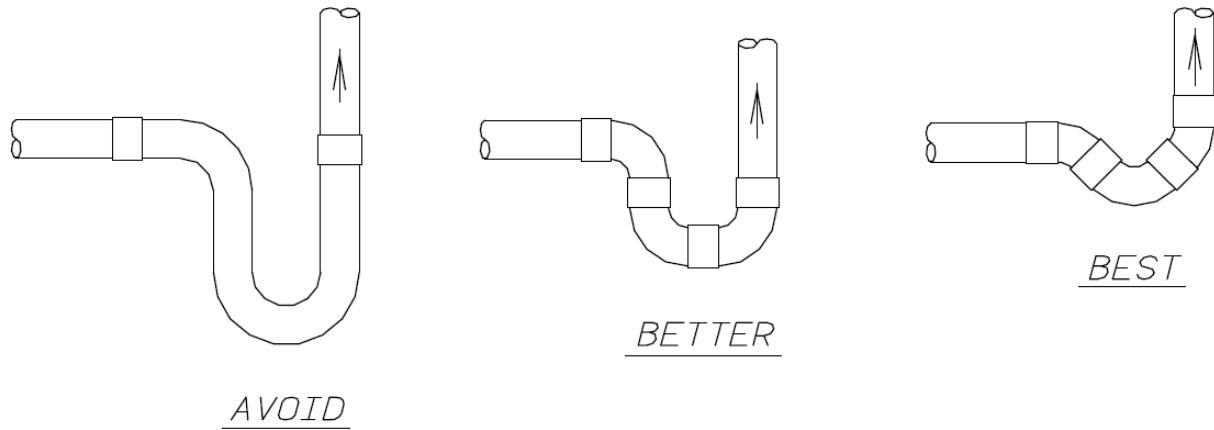

Figure 12: Minimum Traps for Discharge Lines

- 7. Flooding head pressure controls such as Alco Headmaster are not to be used since they cause excessive subcooling of the returned liquid refrigerant and interfere with reliable ice harvest.
- 8. The discharge and liquid lines must be insulated with 1/2 in. (13 mm) Armaflex insulation or equivalent.
- 9. Use only ACR grade copper pipe, Type L. Table 4 has recommended line sizes. Figure 14 shows a typical condenser.

Table 4: Pounds (Kilograms) of Refrigerant to Add vs. Line Length

Liquid Line Size	75 ft. (23 m)	100 ft. (30 m)	125 ft. (38 m)	150 ft. (46 m)
1/2" (12 mm)	-	-	-	2 (1)
5/8" (15 mm)	-	2 (1)	4 (2)	6 (3)
7/8" (22 mm)	-	4 (2)	8 (4)	12 (6)
1-1/8" (28 mm)	-	6 (3)	12 (6)	18 (8)

- 10. The distance between the ice machine and condenser must not exceed 150 ft. equivalent (45.8 m). Table 5 shows equivalent lengths of various copper fittings.

Table 5: Equivalent Feet (Meters) Due to Friction

Copper Tubing Type "L"	1-1/8 in. (28 mm)	1-3/8 in. (35 mm)	1-5/8 in. (42 mm)	2-1/8 in (54 mm)
Globe valve (open)	28 (8.5)	36 (11)	42 (12.8)	57 (17.4)
Angle valve (open)	15 (4.6)	18 (5.5)	21 (6.4)	28 (8.5)
90° Elbow	3 (0.9)	4 (1.2)	4 (1.2)	5 (1.5)
45° Elbow	1.5 (0.46)	2 (0.6)	2 (0.6)	2.5 (0.76)
Tee (90° turn through)	6 (1.8)	8 (2.4)	9 (2.7)	12 (3.7)
Tee (straight through)	2 (0.6)	2.5 (0.76)	2.8 (0.85)	3.5 (1.1)

- Condensers must be provided with a cold weather valve kit. These valves allow one-half of the condenser to be disabled in cold weather. Running the ice machine with one-half of the condenser in cold weather allows for consistent condensing pressures, particularly in windy conditions. Figure shows a diagram of the cold weather valve kit.

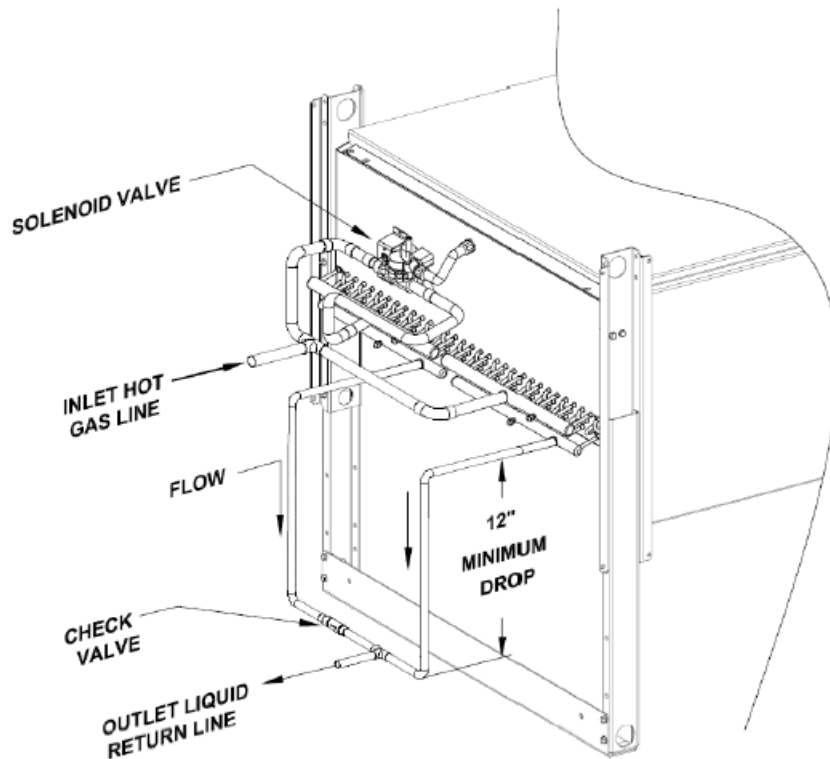
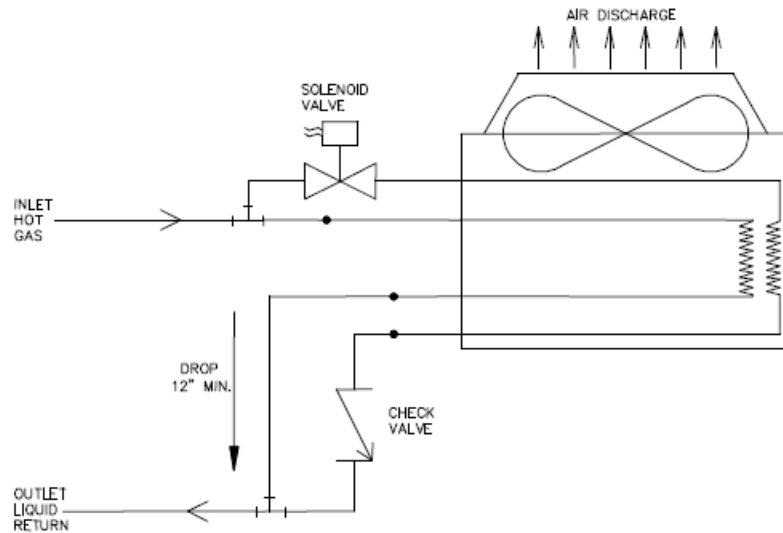

Figure 13: Condenser Field Piping 50-50 Slit Coil (Cold Weather Valve Kit)

Note: Condenser return lines supplied by customer. Check valve supplied by Vogt.

- Condensers with multiple fans must be provided with a thermostat to turn off unneeded fans in cold weather. Turning off unneeded fans reduces the on-off cycling of the fans and allows for consistent condensing pressures and warm gas for ice harvesting.

13. When extreme cold conditions are expected or encountered (outdoor temperatures below 0°F [-18°C] and wind speeds greater than 15 MPH [24 km/h]), it may be necessary to install a protective enclosure around the condenser. Louvers may also be used for varying conditions.
14. After installation, the field installed lines are to be evacuated to a vacuum of 500 microns or less and held for at least one hour. After the vacuum pump is removed, a vacuum of 500 microns or less should be held for at least 5 minutes.
15. The machine is shipped with a full operating charge of refrigerant sufficient to fill the condenser and connecting lines. If the condenser piping is longer than 50 ft. (15 m) in one direction, additional refrigerant may need to be added to retain enough refrigerant in the receiver for thawing purposes. Table X is a guide for additional charge to be added based on line length.
16. All piping must be done in accordance with applicable local and national codes.
17. The following guidelines are strongly suggested. While they do not affect the machine warranty, they may be required for safe operation and to comply with applicable electrical and mechanical codes:
 - a. Check local electrical codes for wiring method.
 - b. The installer must provide a disconnect switch(s) adjacent to the condenser.
 - c. Electrical connections between the condenser and the Tube-Ice® machine require a minimum of 10 ga. wire for 200/230V motors and 14 ga. wire for 400/460V motors. For control wiring, a minimum of 14 ga. wire should be used.
 - d. All electrical fittings and components exposed to the weather must be suitable for outdoor installation.

The design total heat rejection (THR) for this Tube-Ice® machine, the recommended air-cooled condenser, and condenser physical and electrical data are shown in

Table 6. Specified energy efficiency ratings for the ice machines are based on the use of the recommended condenser and approved piping practices.

TABLE 6 - Air-Cooled Condenser Data

Ice Machine Model	HFO10
Recommended Condenser	BNHD06A044
Total Heat Rejection: BTU/hr at 60 Hz. (15°F TD) BTU/hr at 50 Hz.	642,000 534,000
Fans: Number HP, Each Total, CFM	6 1.5 59,400
Full Load Amps: 1 ph., 208/230V, 60 Hz 3 ph., 208/230V, 60 Hz 3 ph., 460V, 60 Hz 1 ph., 200/220V, 50 Hz 3 ph., 200/220V, 50 Hz 3 ph., 400V, 50 Hz	N/A 42 21 N/A 42 21
Weight, lbs.: Net Shipping Operating (maximum flooded)	1980 1980 2010
Condenser dimensions, inches: A (Width) B (Length) C (Height) D (Leg centerline) E (Leg centerline) F (Clearance below)	88" 180" 49.13" 53" *159" (3) 23.25"
Recommended Line Sizes, OD: Liquid (All lengths & orientations) Discharge Gas Vertical Up, All lengths Horizontal Or Down, < 75 ft. Horizontal Or Down, > 75 ft.	1-3/8" 1-5/8" 1-5/8" 2-1/8"
Connections at Condenser: Liquid (ODC) Discharge Gas (ODC) Connections at Machine: Liquid (ODC) Discharge Gas (ODC)	2-1/8" 2-1/8" 1-1/8" (1-1/4"-12) 1-3/8" (1-3/4"-12)

* Note: Condenser has legs in middle

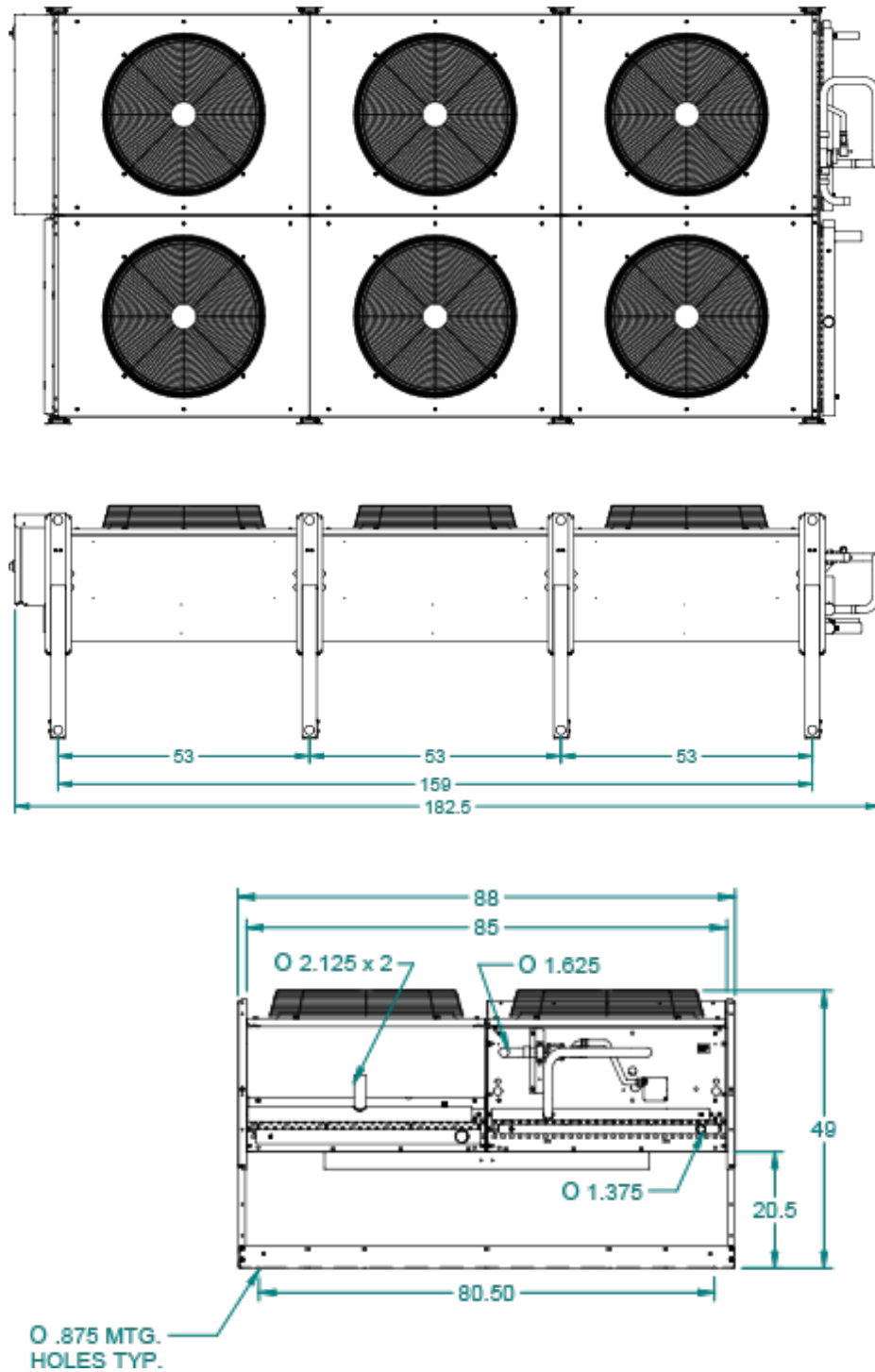

Figure 14: Condenser Dimensions

Recommended condensers provide the indicated total heat rejection at 90°F (32°C) ambient, 100°F (38°C) condensing. Vogt Ice, LLC is not responsible for head pressure problems if condensers other than those recommended are used. For continuous operation at ambient temperatures above 105°F (40°C), consult the factory for a larger condenser.

Air Cooled Condenser Wiring

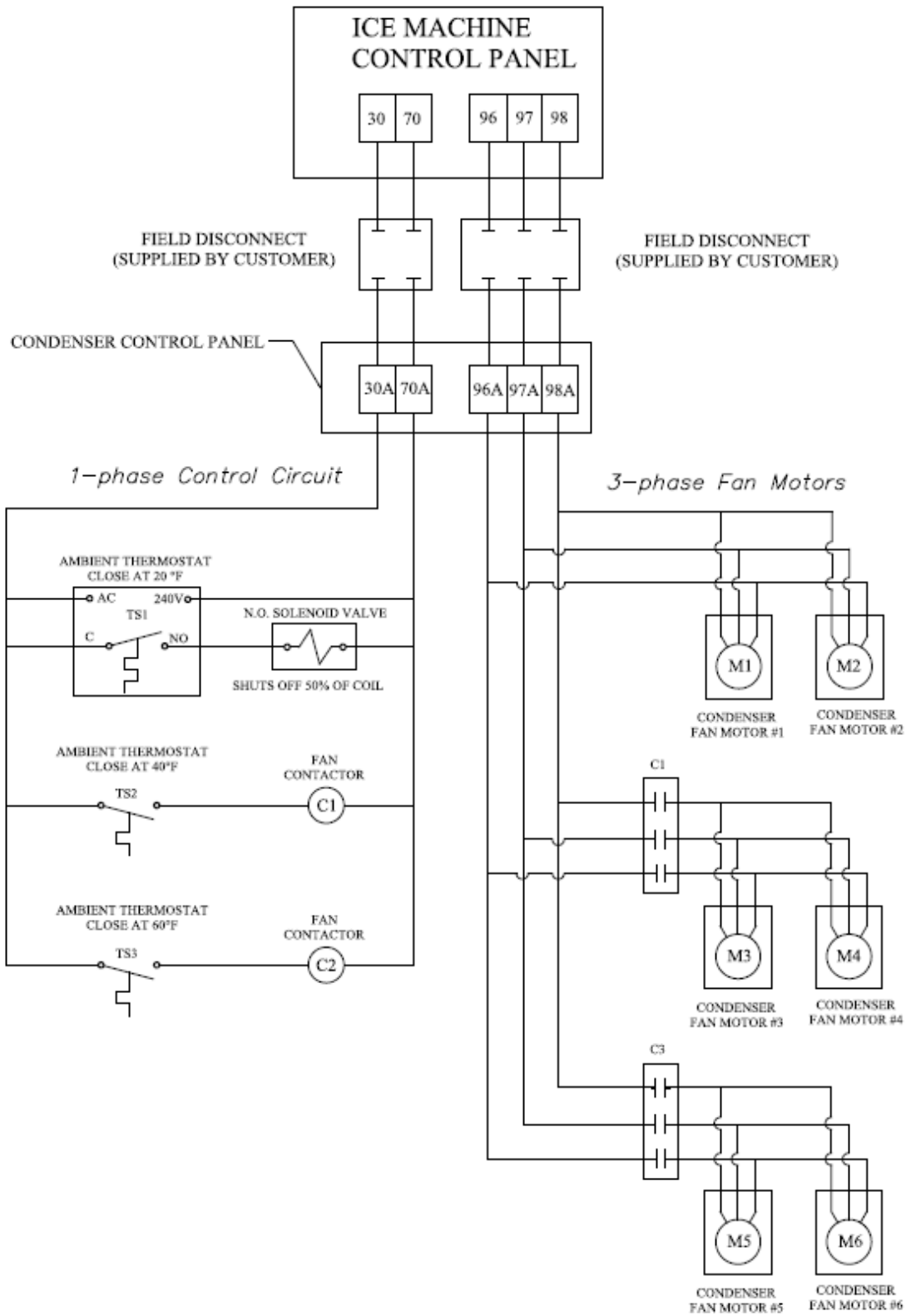

FIGURE – 15
Wiring For BOHN BNHD06A044 (Standard HFO10)
Six Fan, 50/50 Condenser Split

Pressure Relief Valves

Pressure relief valves are included with this Tube-Ice® machine. One is located on the freezer (low-side), one is located on the top of the condenser (high-side), and a third is located on the top of the receiver (high-side). These valves are designed to vent in emergency conditions. This ensures that the vessel internal pressure does not exceed the maximum allowable pressures as stated on the vessel nameplates.

Vent each of the pressure relief valves to a safe outdoor location away from people and building openings in accordance with local and national codes.

Warning: Pressure relief valves must be replaced after five years of service. Before replacing relief valves, review requirements per current local and national codes. Valve replacement should be performed only by service personnel experienced and certified in refrigeration and qualified to work with high-voltage electrical equipment. If a relief valve discharges, the valve must be replaced before putting the machine back into service.

Relief valves do not properly reseal after a discharge event. Contact Vogt SuperCare Customer Service at 1-502-635-3000 or 1-800-853-8648 for replacement valves.

Wiring and Electrical Connections

Warning: Only service personnel experienced and certified in refrigeration and qualified to work with high-voltage electrical equipment are allowed to install or work on this Tube-Ice® machine.

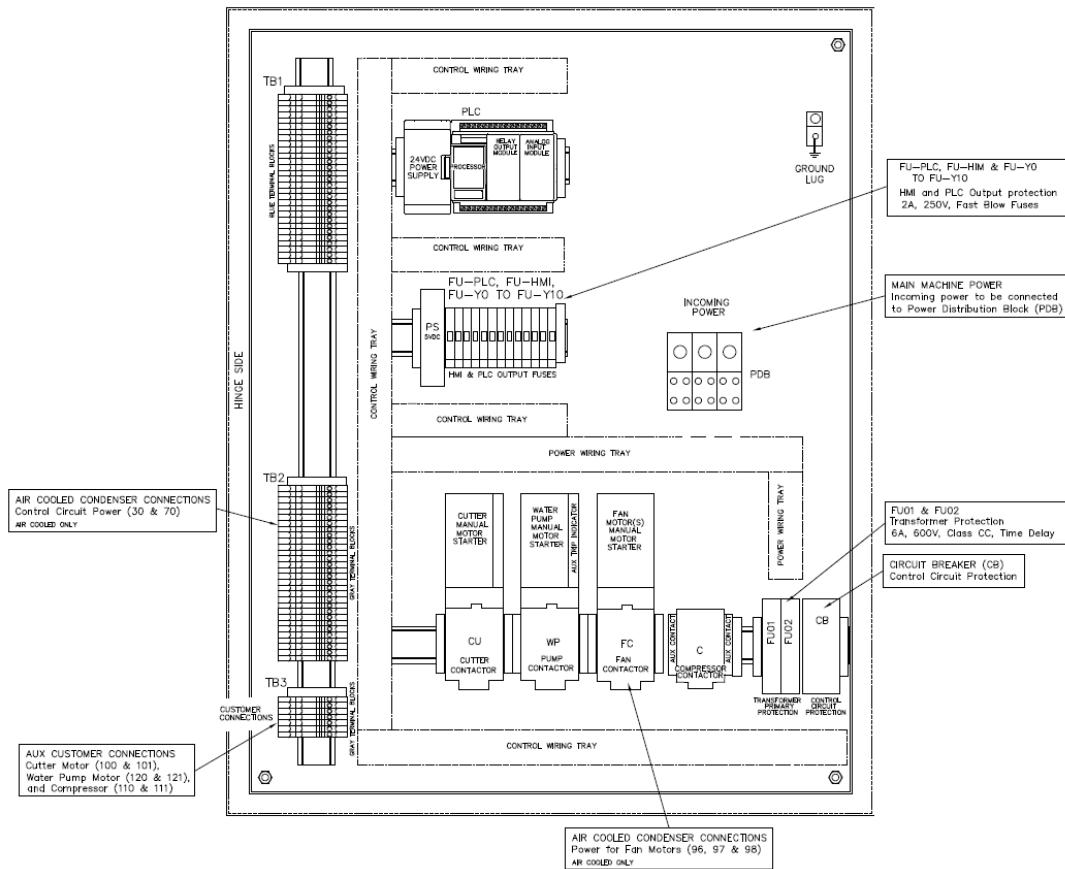

Figure 12: Control Panel Power Connections (60 Hz)

Table 3 shows how to properly size wiring connections. A fused disconnect must be provided near the Tube-Ice® machine. Connect three-phase power to Terminals L1, L2, and L3 on the power distribution block (PDB) for operation of the Tube-Ice® machine and its controls. Rotation checking of cutter motor and water pump is required. Also, if one leg of the three-phase power is higher or lower, then it should be connected to Terminal L2. Connect the ground wire to the provided ground lug (not shown).

Table 7: Electrical Specifications

Standard Voltages	Water-Cooled		
	Full Load Amperage	Min. Ampacity	Max. Fuse
208/230V, 3ph, 60 Hz	88.1	108.3	190
460V, 3ph, 60 Hz	43.9	54	95
220V, 3ph, 50 Hz	N/A	N/A	N/A
400V, 3ph, 50 Hz	54.7	66.9	120

Phase Check

CAUTION Do not attempt to start the machine without priming the water pump and insuring proper rotation of both the cutter motor and pump motor.

Cutter and pump motor rotation are synchronized at the factory but must be checked at installation. For ice production, the cutter disc, as viewed at the ice discharge opening, should turn from left to right. The pump rotation should match the marking on the pump housing. The pump must be primed by starting the machine in Clean mode and allowing it to run for several minutes. To change the direction of rotation for the motors, disconnect the power and reverse L1 and L3 (incoming power wires) at the motor contactor in the control panel.

Voltage Imbalance

Voltage imbalance can cause motors to overheat and fail. Voltage imbalance between any two legs should be no greater than 2%.

Example: Supply voltage = 230V – 3-Phase – 60 Hz

Voltage Readings:

A-B = 220 Volts
 B-C = 225 Volts
 A-C = 227 Volts

} Average = 224 Volts

(A-B) 224-220 = 4 Volts (Highest Deviation)

(B-C) 225-224 = 1 Volt

(A-C) 227-224 = 3 Volts

% Voltage Imbalance = 100 x (4/224) = 1.78% “Acceptable”

CAUTION Contact your local electric utility company if the supply **voltage phase imbalance is >2%**.

Current Imbalance

Voltage imbalance causes a current imbalance, but a current imbalance does not necessarily mean that a voltage imbalance exists. A loose terminal connection or a buildup of dirt or carbon on one set of contacts would cause a higher resistance on that leg than on the other two legs. Current follows the path of least resistance; therefore, if Terminal L1 is loose or dirty, L2 and/or L3 will have higher current.

Higher current causes more heat to be generated in the motor windings. The maximum acceptable current imbalance is 10%.

Example:

Current Readings:

L1 = 96 Amps	}	Average = 95 Amps
L2 = 91 Amps		
L3 = 98 Amps		

(L1) $96 - 95 = 1$ Amp

(L2) $95 - 91 = 4$ Amps (Highest Deviation)

(L3) $98 - 95 = 3$ Amps

% Current Imbalance = $100 \times (4/95) = 4.2\%$ "Acceptable"

Installation Checklist

Complete a visual check of the following before continuing or opening any valves:

- Check all joints for leaks that may have developed during shipment.
Note: The machine was shipped in a pumped down state, but a small positive pressure should remain in the freezer (20–25 psig [1.4–1.7 bar]). Verify with the freezer pressure gauge.
- All refrigerant piping, water supply, and drain connections properly conform to the requirements in this manual and are properly connected to inlets and outlets.
- The electrical supply is properly sized for fuses and for compliance to local and national codes. Refer to the machine nameplate for minimum circuit ampacity and maximum fuse size.
- All field-installed equipment (augers, conveyors, cooling towers, bin level controls, etc.) is properly installed.
- The applicable portion of the **Warranty Registration/Start-Up Form** has been completed and sent back to Vogt Ice.
- Check the oil level of the cutter gear reducer.
- The water distributors at the top of the freezer should be in position and fit snugly against the tubesheet face.

CAUTION

The compressor crankcase heater should be energized for a minimum of two hours, and the oil temperature should be 100°F–110°F (38°C–43°C) before attempting to start the compressor.

Start-Up, Shutdown, and Operation

Start-Up Checklist



Warning: Only service personnel experienced and certified in refrigeration and qualified to work with high-voltage electrical equipment should be allowed to install or work on this Tube-Ice® machine.

Make sure all of the following items have been checked before starting the machine for the first time:

- Check that the water inlet connections are attached properly. The water inlet shutoff valves for the condenser and the water tank should be open. The water level in the water tank should be at a height where the makeup water float valve will be closed when the machine is idle.
- Make sure the cutter motor gear reducer is lubricated.
- Check that the compressor crankcase oil level is at the proper height as indicated by the compressor body sight glass.
- Open all necessary valves, including:
 - Compressor service valves
 - Thawing gas-line stop valve
 - King valve
 - Both float switch stop valves
- Except the charging valves, check that all stop valves in the refrigerant system are open, according to the attached tags. All valves are tagged with instructions.
- Immediately after opening the refrigerant valves, check the entire machine for refrigerant leaks with an electronic leak detector or by doing a bubble test.
- Check that all water supply lines are open to the water tank and all water tank drain valves are closed.
- Set the **Ice/Off/Clean** switch to the **Ice** position.
- Close the exterior disconnect switch to energize the crankcase heater, and check supply voltage against that on motor nameplate for compliance before switching on disconnect.

Start-Up Procedure (Initial Start-Up)

Note: The machine will start in harvest mode when set to **Ice**. If the pump is already primed, skip to Step 4.

To perform the start-up of the machine, follow the steps below:

1. Press the **Run Water Pump** touch screen button on the HMI to start the water pump.
2. The pump can be stopped and started by pushing **Run Water Pump** touch screen button. The water should be circulated for a minimum of 5 minutes to prime the pump, purge the tubing of air, and lubricate the cutter bearing. By default, the pump will run for 10 minutes and shut off.
3. When there is good water flow, press the **Ice** touch screen button. The screen will change and show the **Start** touch screen button. Pressing the **Start** touch screen button will start the machine in a harvest (thaw) period with the compressor running.
4. At the termination of the harvest (thaw) period, the machine will begin the freeze period.
5. Be sure to observe a minimum of 4 cycles of ice production to confirm the satisfactory operation of the machine (approximate time for 4 cycles is about 200 minutes).
6. Complete the remaining part of the **Warranty Registration/Start-Up Report** upon initial machine start-up and return it to Vogt Ice, LLC.

Shutdown Procedure

CAUTION

The red **Stop** button should only be used for emergency shutdown.

For normal shutdown, use the **Off** touch screen button on the HMI and follow the steps below:

1. Press the **Off** touch screen button. Do not use the machine disconnect or the red **E-Stop** to stop the machine. If the disconnect is used, the crankcase heater is de-energized, and liquid refrigerant migrates to the compressor.
2. During a freeze period, the machine will continue to run.
3. At the completion of the freeze period, the machine will harvest and stop. The completion of a cycle (1 freeze plus 1 harvest) ensures that all ice is removed from the freezer to prevent refreeze when the machine is restarted. Before turning off, the machine will perform a partial pumpdown.
4. During a harvest period, the machine will complete the harvest, perform a partial pumpdown, and stop.

Start-Up and Shutdown Tips

- If the operation of your machine is not controlled by a timer, bin level control, or some other mechanism to automatically start and stop ice production, you should use only the touch screen HMI to start and stop the machine.
- By pressing the **Off** touch screen button, the machine will stop after the next harvest period. It will perform a partial pumpdown before turning off.
- Do not use the **E-Stop** button or the machine disconnect for normal shutdown of the machine.
- Disconnect the machine only in an emergency or for safety when performing certain service or repairs to the machine. The compressor crankcase heater is de-energized when the machine is shut down.
- The **Manual Harvest** touch screen button can be used to initiate a harvest period. When it is pushed during a freeze period, it will immediately initiate a harvest period.

Ice Quality

Your HFO10 has been set up at the factory to produce the finest Tube-Ice[®] possible. The ice produced in the freezer should have a small hole in the middle of each tube to avoid permanently damaging the freezer. Table 8 shows recommended hole sizes for determining ice quality. For further information, refer to Chapter 9.

Table 8: Average Hole Size in Tube-Ice[®]

Tube Size in. (mm)	1 (25)	1-1/4 (32)	1-1/2 (38)
Hole Size in. (mm)	1/16–1/8 (1.6–3.2)	1/8–3/16 (3.2–4.8)	1/4–3/8 (6.4–9.5)

Adding Refrigerant

CAUTION

Be sure to follow all local and federal regulations regarding the handling of refrigerants and their illegal emission into the atmosphere.

Check the refrigerant level after the machine has operated for a few cycles. It should be slightly above the minimum operating level, as indicated on the label on the receiver, a few minutes before the start of a thawing period.

If the level is low at this time, sufficient refrigerant should be added to the system to raise the level above this point.

Note: Refrigerant can only be added during the freeze period.

Add no more than 10 lb. (4.5 kg) of refrigerant and allow the machine to operate for several cycles before checking the level again.

It is also possible to check the refrigerant level by pumping down the machine (Refer to *Pumpdown*). When the machine is pumped down, some liquid should be observed in the receiver's sight glass.

Refrigerant must be added in liquid form through the machine's charging valve. No air or other non-condensable gases should enter the system when filling the machine with refrigerant. The compressor crankcase heater must be energized for a minimum of two hours before starting and running the compressor.

While the machine is running, add refrigerant according to the steps below:

1. Connect the charging valve on the machine to the refrigerant cylinder using a hose or pipe suitable for R513A service. Refer to the instruction card attached to the refrigerant cylinder.
2. Open the valve on the refrigerant cylinder and purge air out of the charging line at the charging valve connection.
3. Open the charging valve on the machine.
4. The charging valve must be closed when the freezer is in a harvest period.



Immediately close the machine charging valve at the start of the harvest period if a refrigerant cylinder is connected. Never leave a refrigerant cylinder connected to the system except during charging operations. Failure to observe either of these precautions can result in transferring refrigerant from the system into the refrigerant cylinder, causing it to overfill and possibly rupture as the liquid refrigerant expands.

Electrical Controls and Their Functions

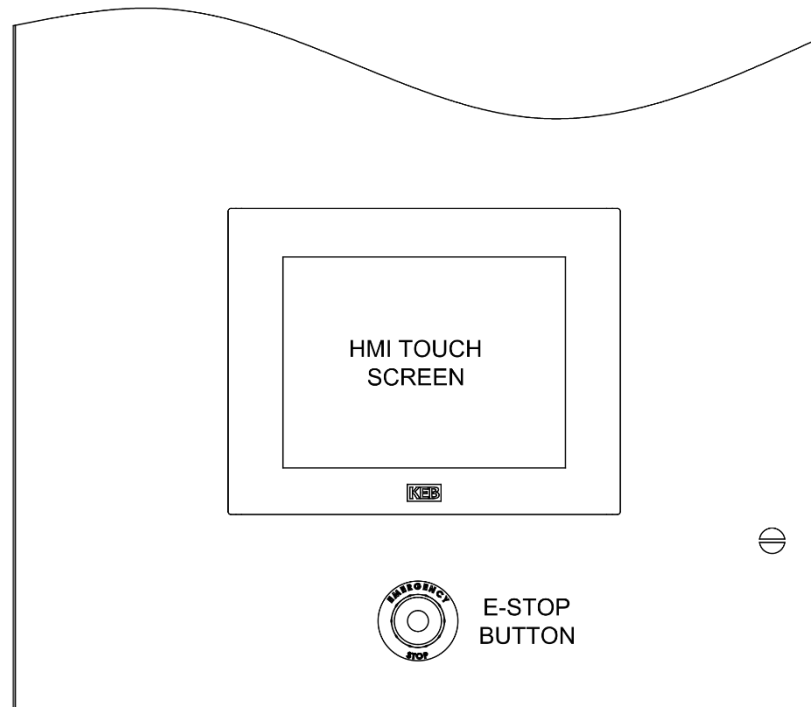

Figure 16: Control Panel (Exterior View)

This machine includes an Allen Bradley PLC with touch screen HMI. All machine control functions like the freezer pressure switch (FPS), the low-pressure safety, the high-pressure safety, the defrost pressure switch (DPS), and the condenser pressure switch (CPS), among others, are handled through pressure transducers and the touch screen.

Note: If damaged, the bin sensor can be replaced without replacing the entire unit. The sensor cable can be extended up to 500 feet (150 m) if using a 16 American wire gauge (AWG) wire. For more information, contact Vogt SuperCare Customer Service.

CAUTION

To provide proper protection for the Tube-Ice® machine and its component parts, be sure to follow the wiring schematic and electrical specification table when incorporating overloads.

CAUTION

The crankcase heater should be energized for a minimum of 2 hours. The crankcase must be free of liquid before attempting to operate the compressor.

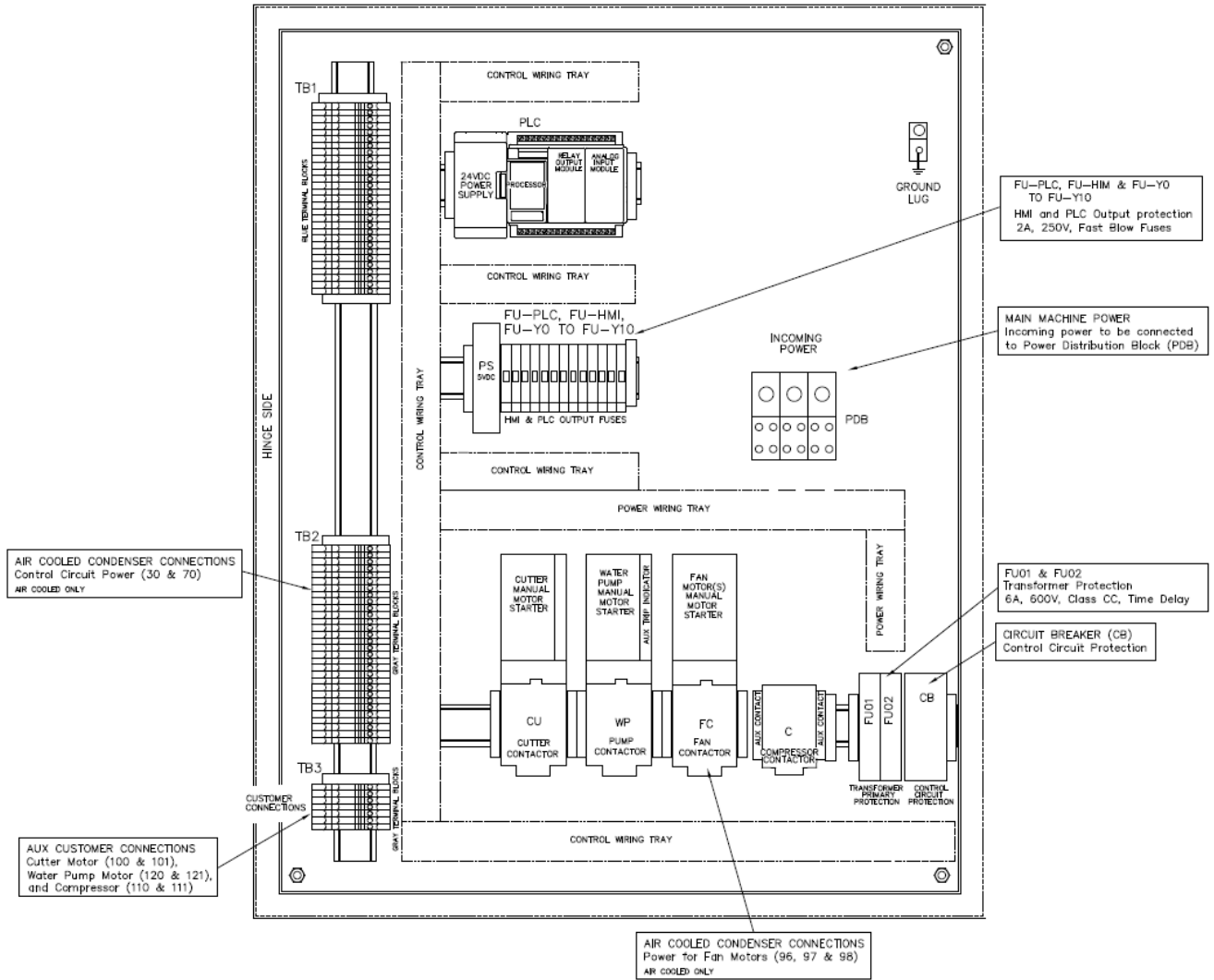

Figure 17: Panel Layout, 60-Hz Non-CE Machines

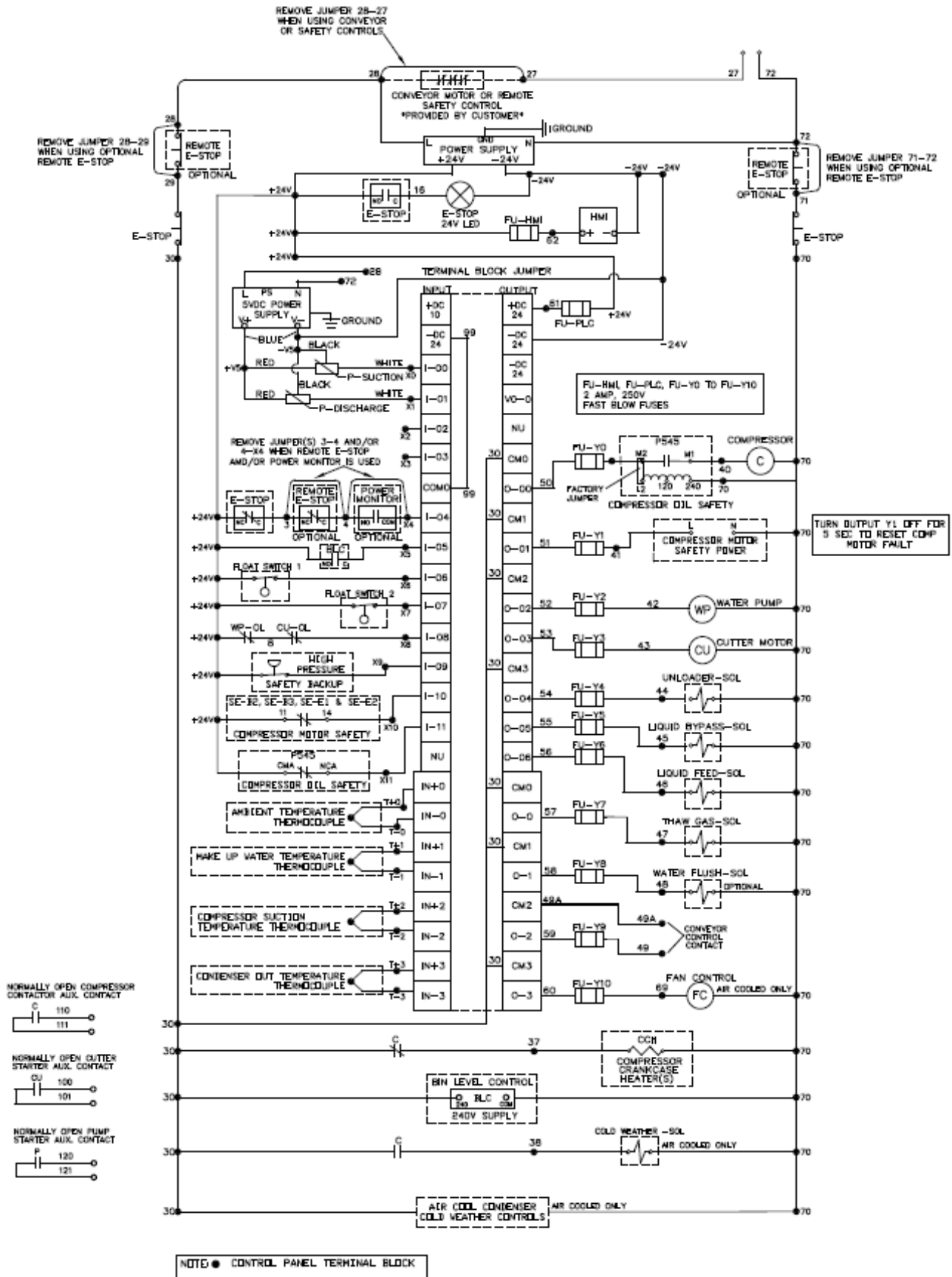

Figure 13: Electrical Schematic, Control Circuit, All Voltages, 60 Hz

60HZ MACHINES

3-PHASE POWER

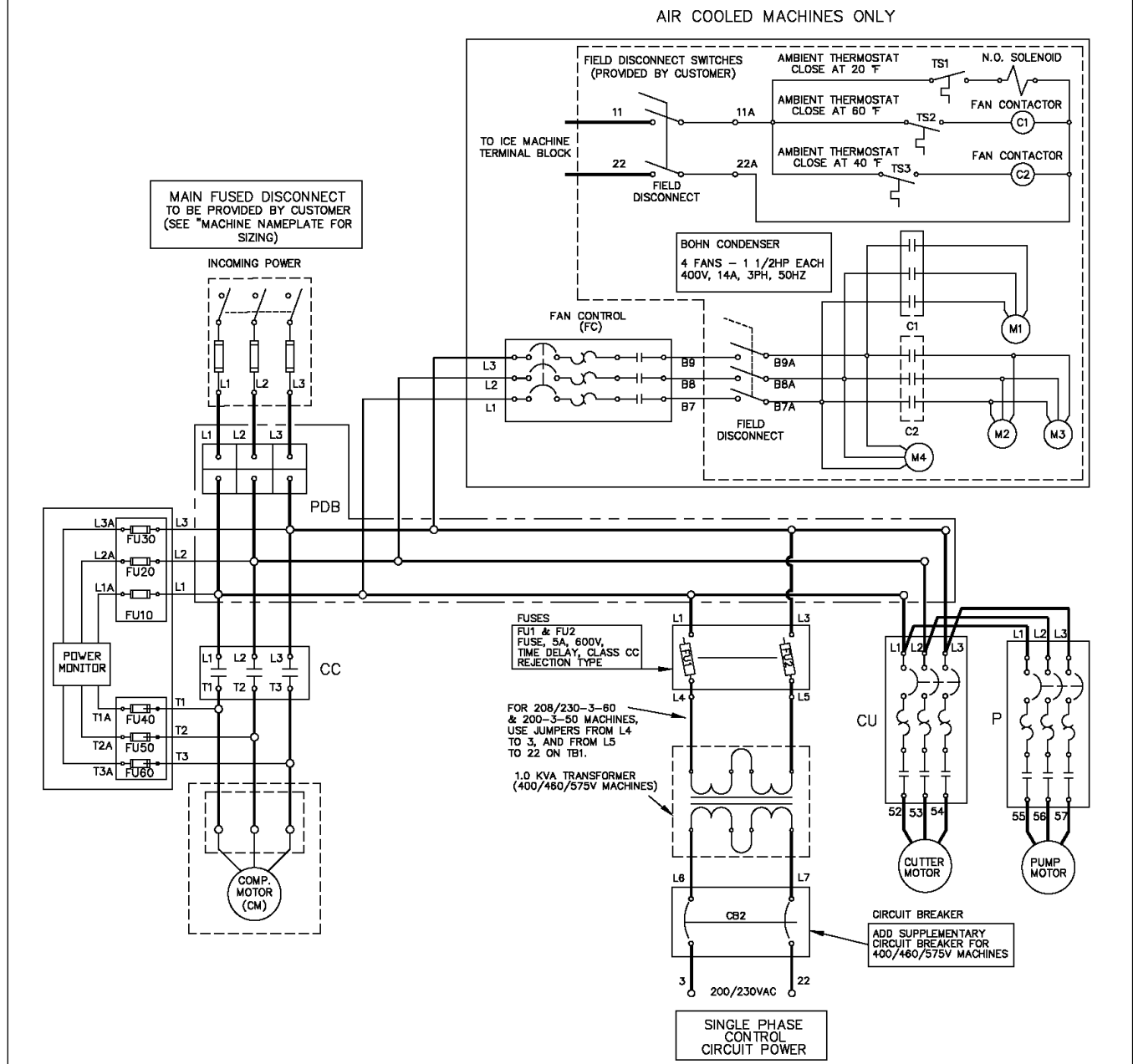

Figure 19: Electrical Schematic, 3-Phase Power, All Voltages 60 Hz

Table 9: Control Panel Component Functions

Component	Function
AX	Auxiliary trip indicator for manual motor starters. Switch opens, turning off the motor when cutter or pump motor starter trips.
CB2	Overload and short circuit protection for control circuit and crankcase heater. (400/460V machines only)
CC	Provides power to the compressor motor. Continuously energized during freezing and thawing. Auxiliary contacts control main power for control circuit components, crankcase heater, control relay, and harvest timer.
CCR	Capacity Control Relay. Controls the loading of the compressor. Y3–25%, Y4–100%.
CR	Control Relay. Controls sequencing of freezing and thawing circuits. Energized during thawing period.
CU	Fan motor starter (manual motor starter and contactor). Starts and stops cutter motor. Provides short circuit and over current protection. Stops cutter motor and ice machine in the event of a mechanical or electrical malfunction that results in excessive motor amperes.
DS	Disconnect switch (CE and Australian approved machines only).
ET	Indicates hours of machine operation. Energized when compressor is operating.
FC	Fan Control motor starter (manual motor starter and contactor). Cycles the fan motor(s) of air-cooled condenser on and off. Automatically activated by the System 450 (air-cooled machines only). Provides short circuit and over current protection. Stops fan motors in the event of a mechanical or electrical malfunction that results in excessive motor amperes.
FU1&2	Overload and short circuit protection for control circuit and crankcase heater.
FU10-60	Short circuit protection for optional power monitor.
P	Pump motor starter (manual motor starter and contactor). Starts and stops pump motor. Provides short circuit and over current protection. Stops water pump motor in the event of a mechanical or electrical malfunction that results in excessive motor amperes.
PBL1	Light indicates a compressor fault. The push button resets the compressor module fault by pressing and holding for 5 seconds. The push button is also used to immediately stop machine operation in case of an emergency.
PB2	Starts machine for manually harvesting. Initiates a harvest period whenever this button is pushed with the Clean/Off/Ice selector switch in the Ice position and machine operating in a freeze period.
PF	Stops the machine when there is a power failure or interruption. Also, stops the machine when the high/low pressure switch, oil pressure safety control, pump overload, cutter overload, compressor overload, or the control circuit breaker is tripped. If the Stop button is pushed, any of the safeties tripped, or there was a power outage, the machine must be manually restarted by pushing Start .

Control Panel Component Functions, cont.

Component	Function
SS	Selector switch. Selects operating mode of machine. When in Clean position, only the water pump runs. This allows cleaner to be circulated through the freezer without making ice. In the Off position, the machine will shut down after the completion of a freeze and harvest period. In the Ice position, the machine will cycle on and off based on a control signal (i.e., bin thermostat or timer) or run continuously until manually stopped by setting the switch to the Off position.
T	Controls the time of the thawing period.
TB1	Main terminal block, which is numbered for multiple wire connections and ease of troubleshooting.
Y3	Compressor loader solenoid for 25% loaded condition.
Y4	Compressor loader solenoid for 100% loaded condition.

Table 10: Part List for VFD Starter Panel – 50 Hz Only

Item No.	Vogt Part No.	Description
CB4	12A7515E09	3-phase Circuit Breaker, 30 Amp, 600V; Feeds power to the main control panel for the water pump, cutter, and condenser fan motors
DS1	12A2790D16	Fused Disconnect, 100A, 600V
	12A2790H06	Disconnect Handle
	12A2790R07	Internal Operating Handle
	12A7504E55	Fuse, 100A, 600V, Class J, Time Delay
EMC	12A7800V51	EMC/RFI Filter, 100A; Used to clean power lines
VFD	12A7800V49	VFD, Powerflex 753, 77 Amp, Frame 5, 50HP HD; Variable Frequency Drive; used to send 60-Hz power to the screw compressor
	12A7800V50	Remote VFD Interface

Allen Bradley PLC with Touch Screen HMI

The Allen Bradley PLC with Touch Screen HMI is replacing and integrating the former standalone freezer pressure switch (FPS), the bin thermostat, the low-pressure safety, the high-pressure safety, the defrost pressure switch (DPS), and the condenser pressure switch (CPS) with pressure transducers and thermocouples that interact with a touch screen interface. Features such as superheat trends, detailed fault history, and remote access have been added to aid in regular operation, maintenance, and service.

HMI Main Menu

The Touch Screen HMI is the visual representation of the control functions contained within the PLC. When the machine is first started, the user is presented with the **MENU** screen. The **MENU** screen is also accessed by pressing the grid touch screen button  from any screen in the HMI.

The touch screen buttons on the **MENU** screen access different submenus within the system. Refer to Figure .

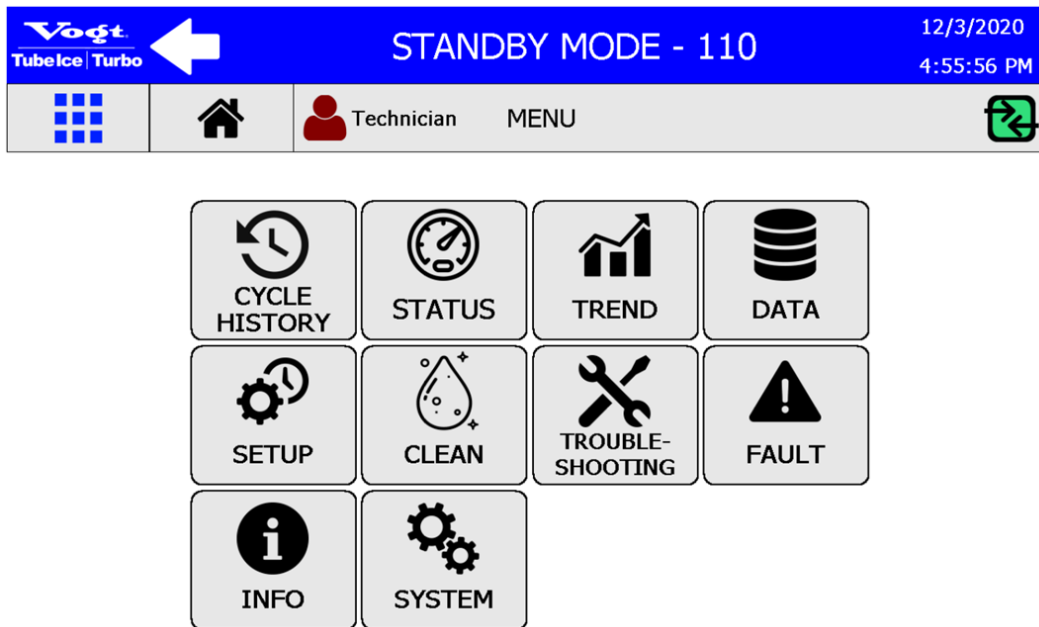

Figure 20: MENU Screen

The **MENU** screen gives access to the submenus below:

- **CYCLE HISTORY** – Displays the Cycle History for the last 50 cycles.
- **STATUS** – Displays the current Suction Pressure, Discharge Pressure, Ambient Temperature, Make-Up Water Temperature, Suction Temperature, and Superheat. Also displays the current setpoints for the **Freezer Pressure Switch** and **High Pressure Safety**.
- **TREND** – Displays graphs of the Suction Pressure, Discharge Pressure, Ambient Temperature, Make-Up Water Temperature, and Compressor Superheat for the last 8 hours.
- **DATA** – Allows the operator to download or email machine data collected by the HMI.
- **SETUP** – Displays the user adjustable setpoints, delays, and safeties such as **Freezer Pressure Switch**, **High Pressure Safety**, **Cutter Delay**, etc.
- **CLEAN** – Allows the operator to enter the clean mode on the machine.
- **TROUBLESHOOTING** – Allows the operator to perform a full pumpdown for before maintenance, check the status of PLC inputs and outputs, and to activate individual PLC outputs to test individual components on the machine (i.e. – water pump, cutter motor, etc). Includes a Log that records maintenance events.

- **FAULT** – Displays historical fault data for the machine.
- **INFO** – Displays information about the ice machine including Serial Number, Job Number, Manufactured Date, etc. Provides access to digital service manual.
- **SYSTEM** – Allows the operator to activate notifications and remote access capability. Provides access to the setup of machine user groups.

The top bar of the HMI displays shortcut menus and system status information. Refer to Figure 21.

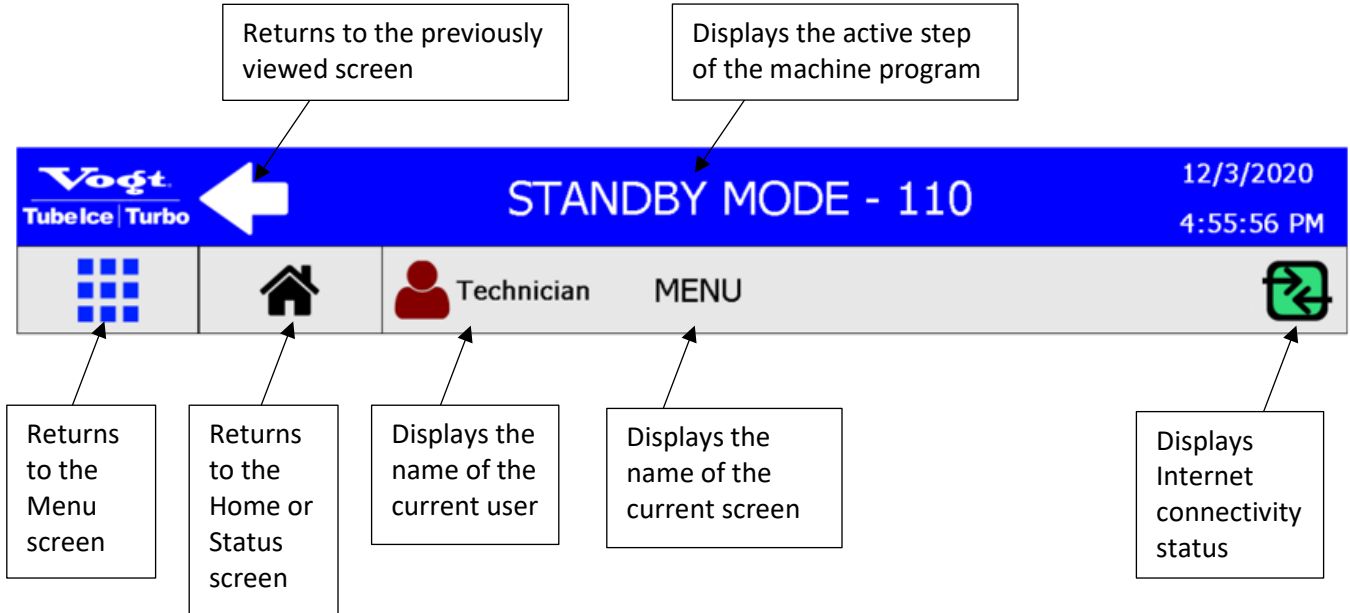







Figure 21: Top Screen Detail

For Internet connectivity status, the system status is according to the color code below:

-  The machine is connected to the Internet and a remote user is logged in.
-  The machine is connected to the Internet, but no remote users are logged in.
-  The machine is connected to the internet and remote access is turned off.
-  The machine is not connected to the Internet.
-  The machine is not connected to the Internet and remote access is turned off.

The Current User icon color is according to this color code:

-  Operator (Password: may28)
-  Technician (Password: oslo47)
-  Manager Password: pau33)
-  Support
-  Developer

HMI Primary Submenus

The HMI contains submenus that provide access to machine functions and reports. The primary submenus are accessed from the **MENU** screen, Figure , and are detailed below. Refer to Figure through **Figure**.



Cycle History		Page 1/10			
Cycle Number	Current	2	3	4	5
Freeze Start Date & Time	16:00:17 12/11/2020	15:38:08 12/11/2020	15:15:43 12/11/2020	14:53:30 12/11/2020	14:32:04 12/11/2020
Freeze Time	18m32s	19m7s	19m24s	19m12s	18m25s
Freeze Avg Make Up Water (°F)	Data Logging in Progress	56.6	56.5	55.9	54.7
Freeze End Suction Pressure (PSI)		11.9	11.8	11.9	12.0
Freeze Avg Discharge Pressure (PSI)		137.1	137.2	137.3	137.2
Harvest Time		3m	3m	3m	3m
Harvest Max Suction Pressure (PSI)		44.7	44.3	45.3	44.9
Total Cycle Time		22m7s	22m25s	22m12s	21m25s

Figure 22: CYCLE HISTORY Screen

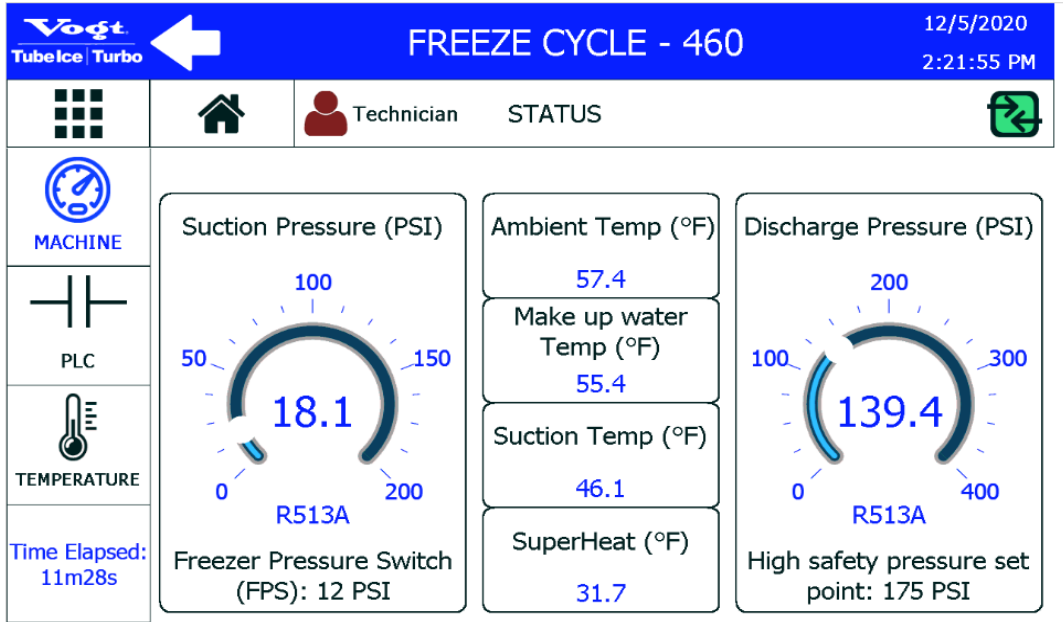

Figure 23: STATUS Screen

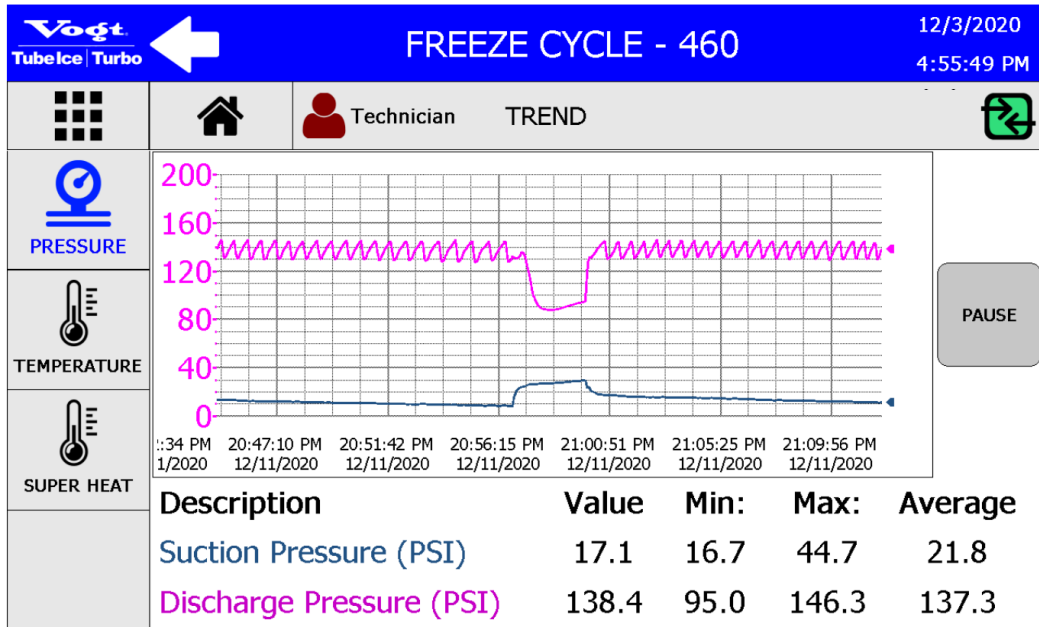

Figure 24: TREND Screen

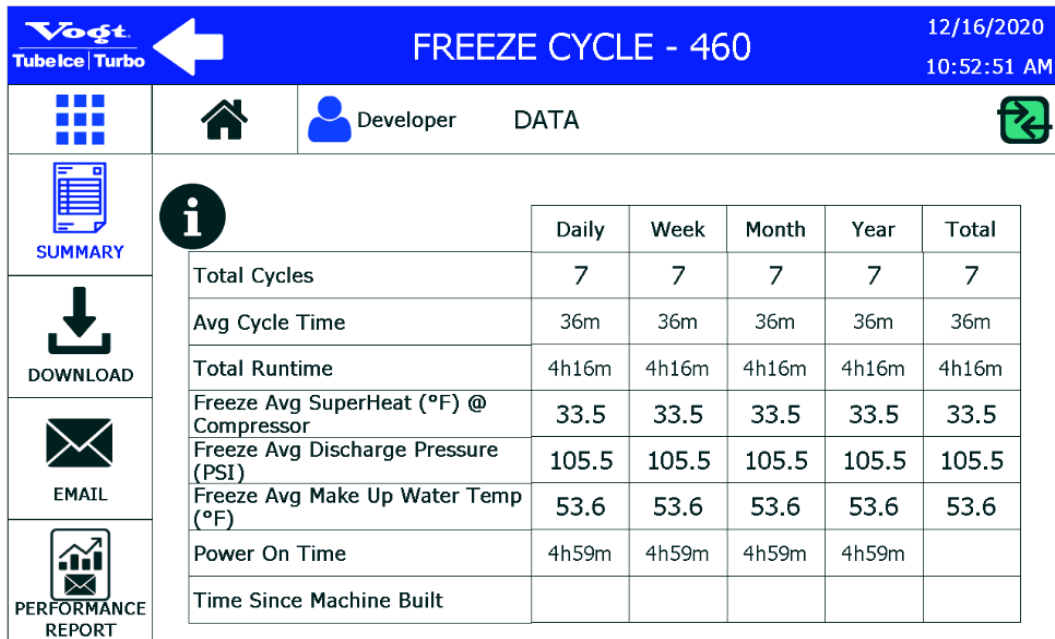

Figure 25: DATA Screen

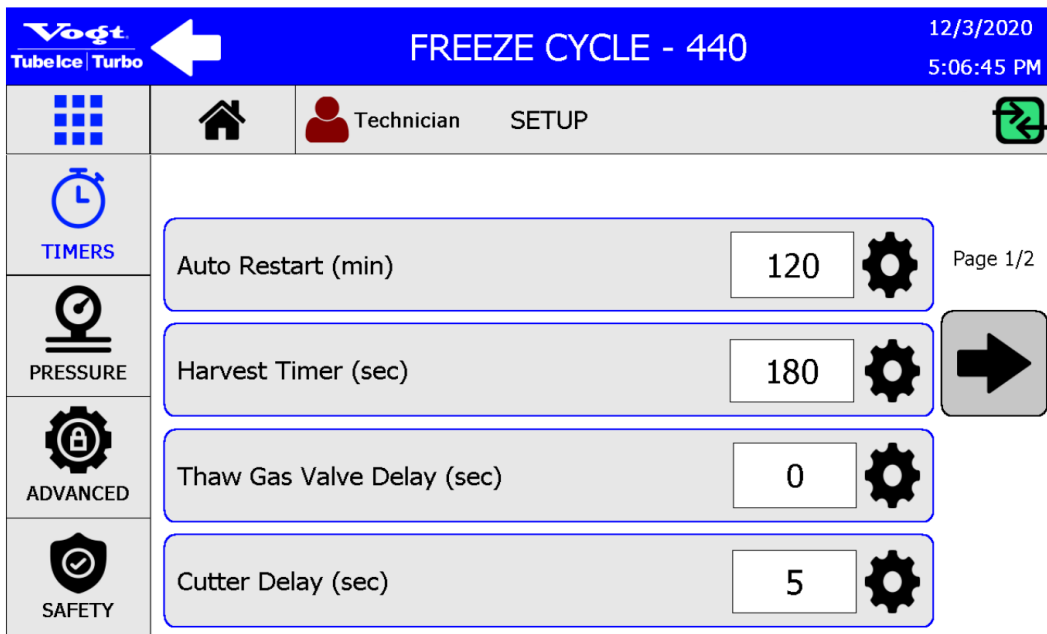

Figure 26: SETUP Screen

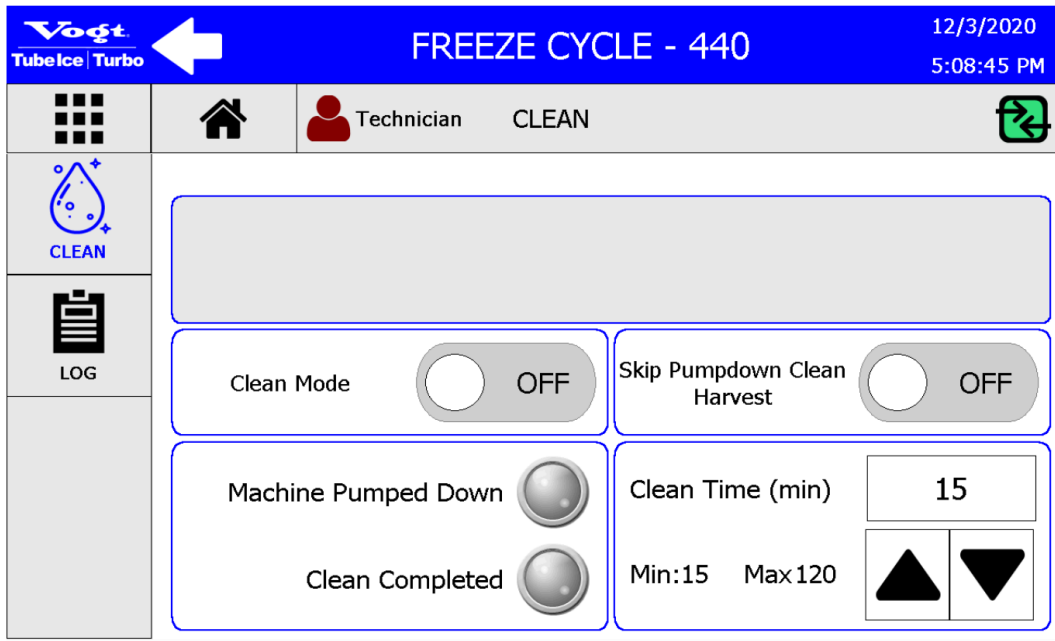

Figure 27: CLEAN Screen

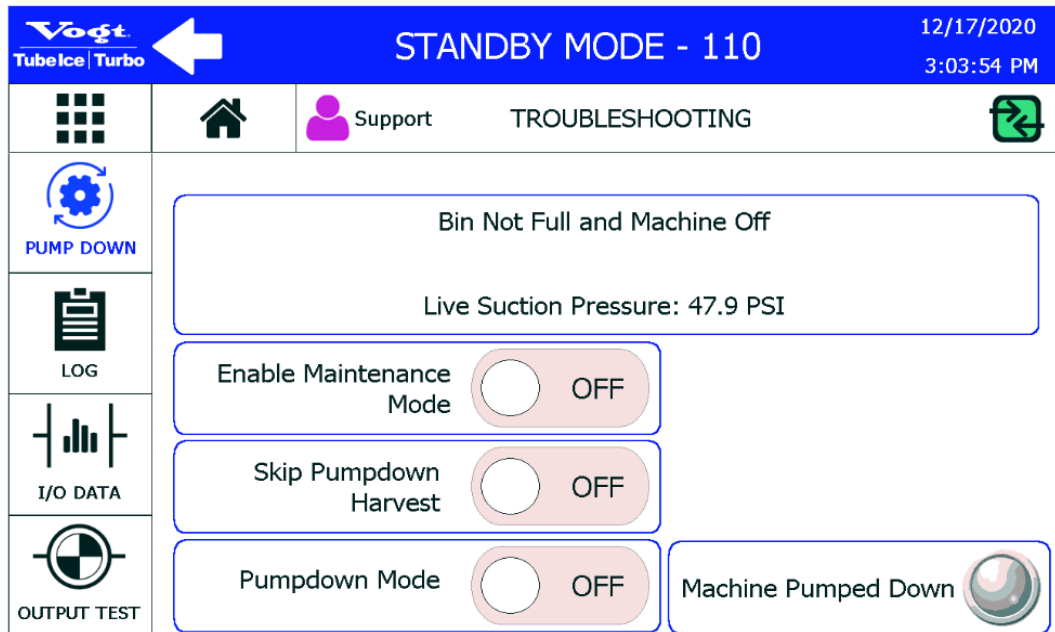

Figure 28: TROUBLESHOOTING Screen

Event Time	User	Event	Description
12/3/2020 3:35:10 PM	Technician	FAULT RESET	Compressor Oil Fault
12/3/2020 3:31:57 PM	Technician	FAULT ON	Compressor Oil Fault During: Startup Mode
12/3/2020 3:31:30 PM	Technician	FAULT RESET	Short Cycle Fault: at least 3 short freeze cycles in a raw
12/3/2020 3:22:30 PM	Technician	FAULT ON	Short Cycle Fault: at least 3 short freeze cycles in a raw During: Harvest Cycle

RESET FAULT Fault Page 1/2

Figure 29: FAULT Screen

<p>i MACHINE</p> <p>? DOCUMENTS</p> <p>? SUPPORT</p>	<p>Model Number: HFO5</p> <p>Serial Number:</p> <p>Job Number:</p> <p>Refrigerant Type: R513A</p> <p>Tube Size: 1 1/4"</p> <p>Manufactured Date: Aug. 2020</p>
---	--

Figure 30: INFO Screen

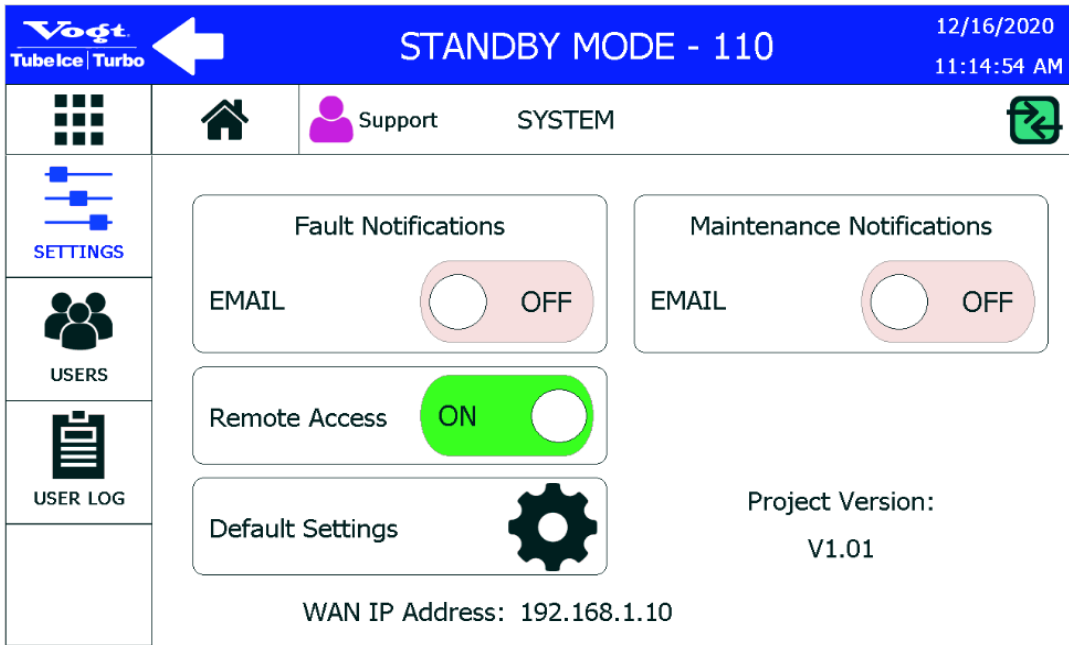

Figure 31: SYSTEM Screen

HMI Home Screen

Pressing the **HOME** touch screen button  from any screen in the HMI will take the operator to the **HOME** screen that displays the primary operational information of the ice machine. Refer to Figure 32.



Figure 32: HOME Screen

Basic machine parameters such as the **Freezer Pressure Switch**, and the **Harvest Timer** can be quickly accessed in the **QUICK SETUP** submenu. See Figure 33.

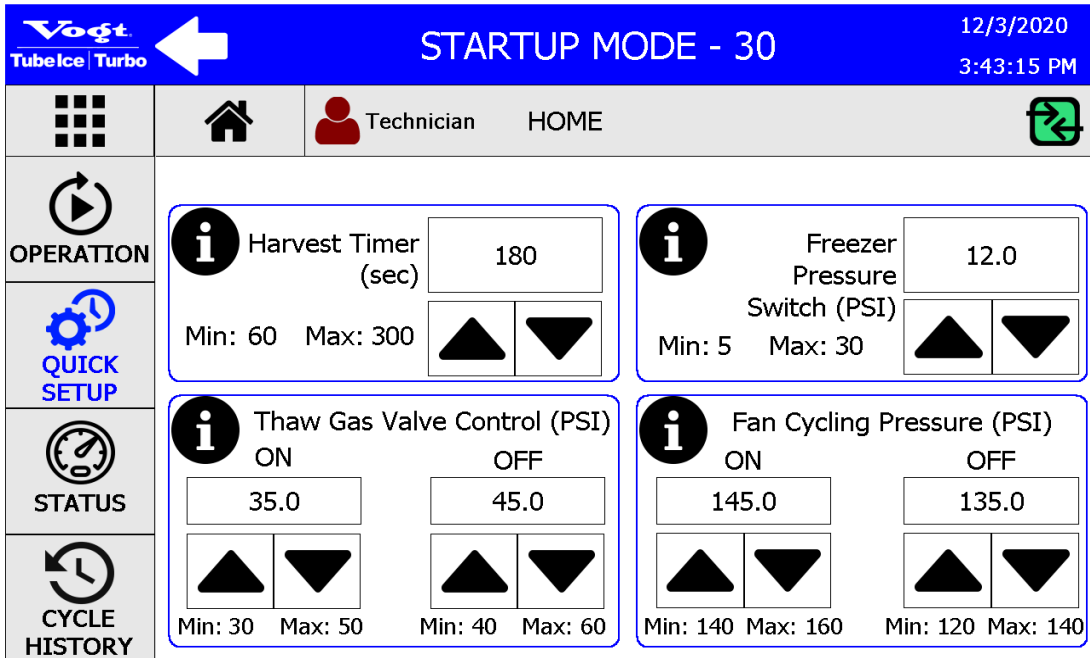

Figure 33: QUICK SETUP

Pressing the information icon **i** provides additional information about each parameter. Figure 34 shows the information available for the **Harvest Timer**.

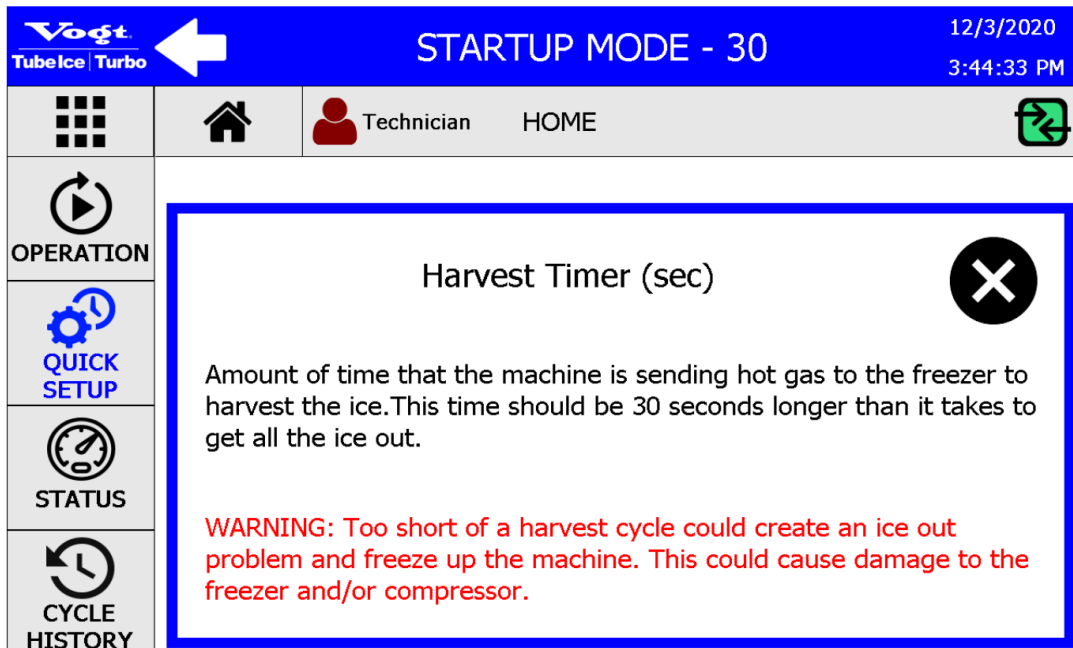

Figure 34: Information Icon Detail

HMI Detailed Screens

Within each primary submenu that is accessed from the main **MENU** screen, Figure , additional menus are available to view specific information about the machine, to access specific functions, or to change specific parameters.

The **STATUS** screen displays the current Suction Pressure, Discharge Pressure, Ambient Temperature, Make-Up Water Temperature, Suction Temperature, and Superheat. From this screen, PLC input and output status is viewed by pressing the PLC submenu touch screen button. See Figure 35.

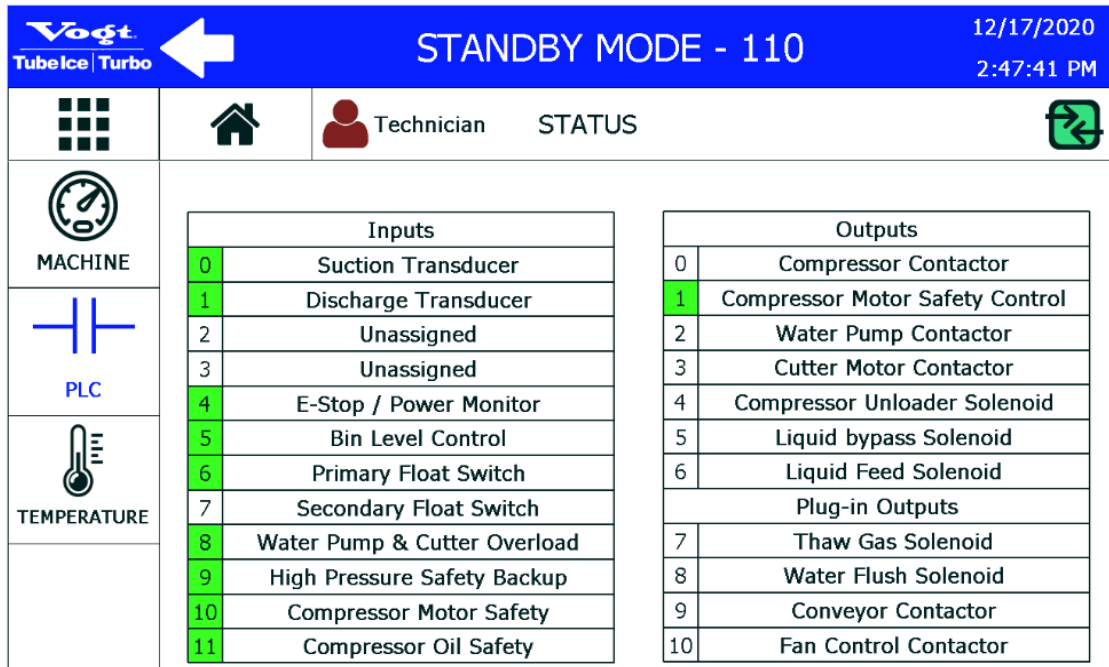

Figure 35: PLC Submenu

The **TREND** screen, Figure, displays Pressure, Temperature, and Superheat graphs by pressing the touch screen buttons. Press the **TEMPERATURE** and **SUPERHEAT** touch screen buttons to view graphs of each. Trend history is available for up to 8 hours by pressing the **PAUSE** touch screen button for the graph. See Figures 36 through Figure 38.

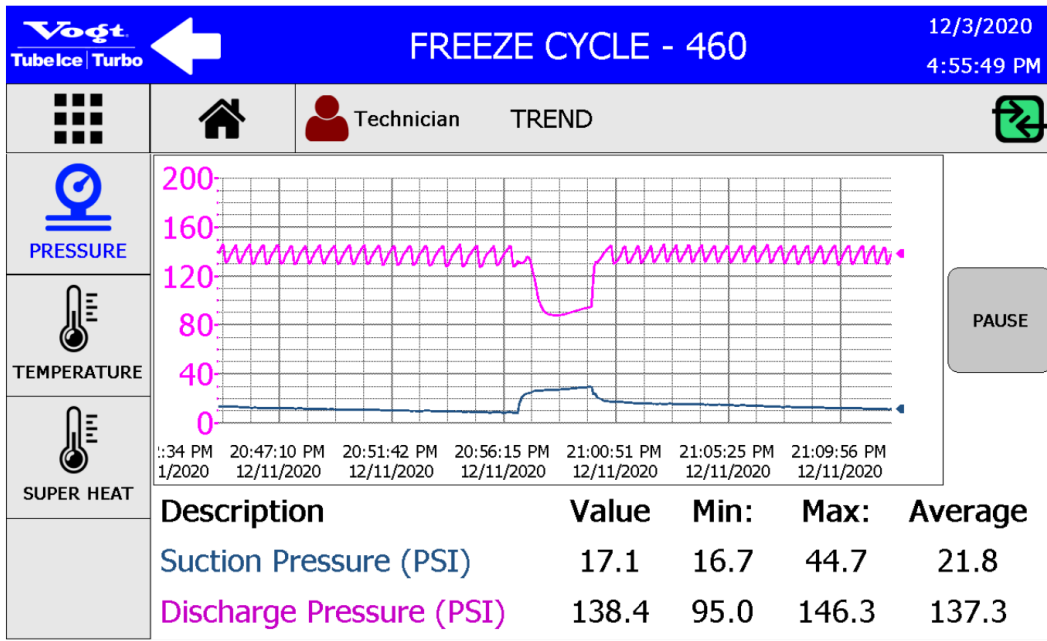

Figure 36: PRESSURE Trend

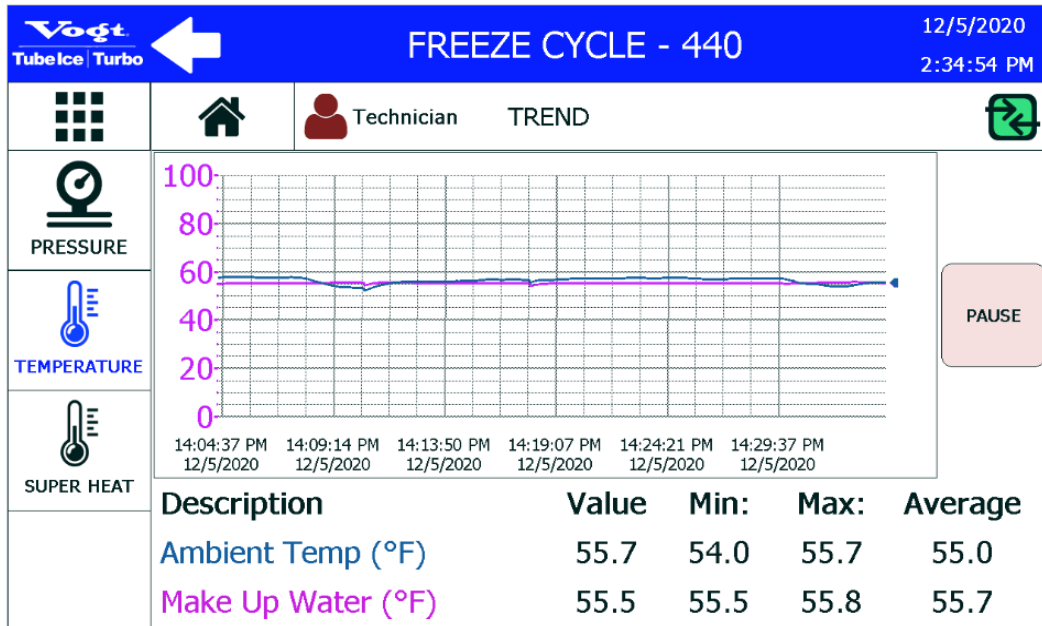

Figure 37: TEMPERATURE Trend

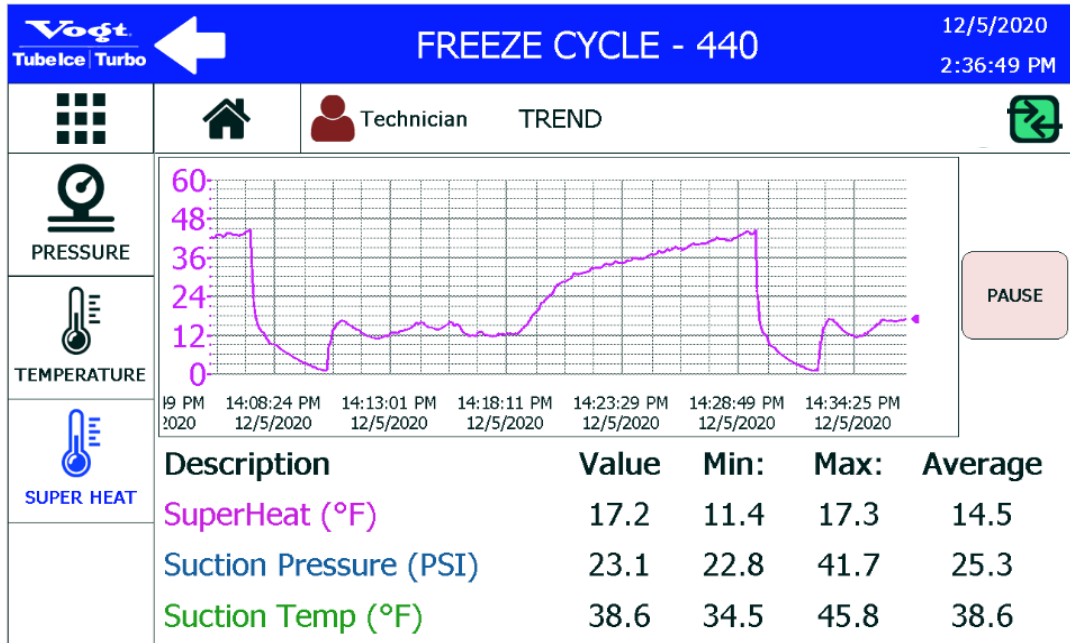

Figure 38: SUPERHEAT Trend

The DATA screen,

Figure, provides cycle data for various periods. The information collected by the HMI can be download to a storage device through the USB ports on the front of the control panel or it can be sent by email if the machine is connected to the Internet. See Figure 39 through Figure 42.

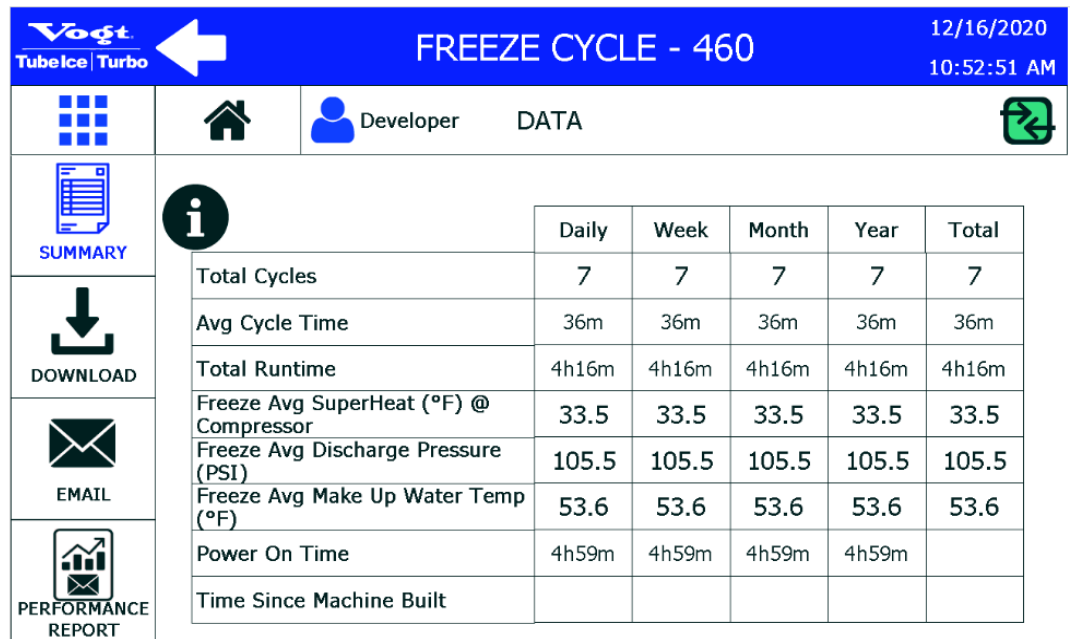

Figure 39: DATA Summary

To download data to an external storage device, follow these steps:

1. Press the **DOWNLOAD** submenu touch screen button on the left side of the **DATA** screen.
2. Insert a storage device in the USB port on the front of the control panel.
3. Select the boxes for the data that is to be downloaded.
4. Press the **DOWNLOAD** touch screen button on the right side of the screen.

The data will be sent directly to the storage device connected to the machine.

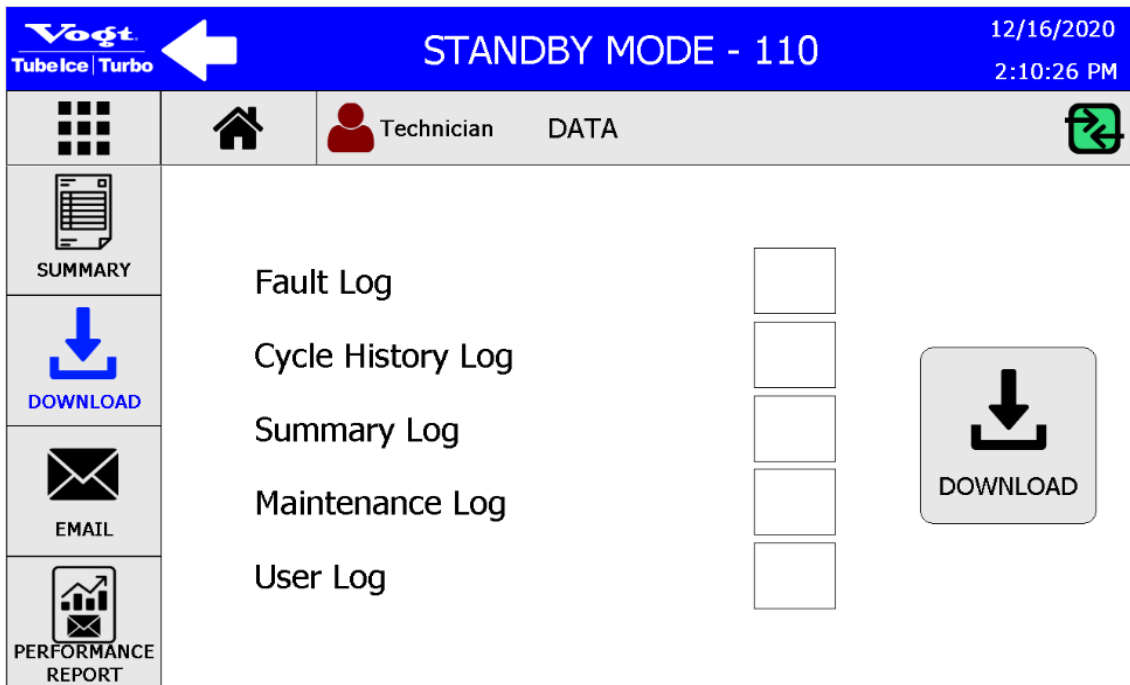

Figure 40: Download

To email data, follow these steps:

1. Press the **EMAIL** submenu touch screen button on the left side of the **DATA** screen.
2. Select the boxes for the data that is to be emailed.
3. Press the **SEND** touch screen button on the right side of the screen.

Note: The data will be sent by email only if the machine is connected to the Internet.

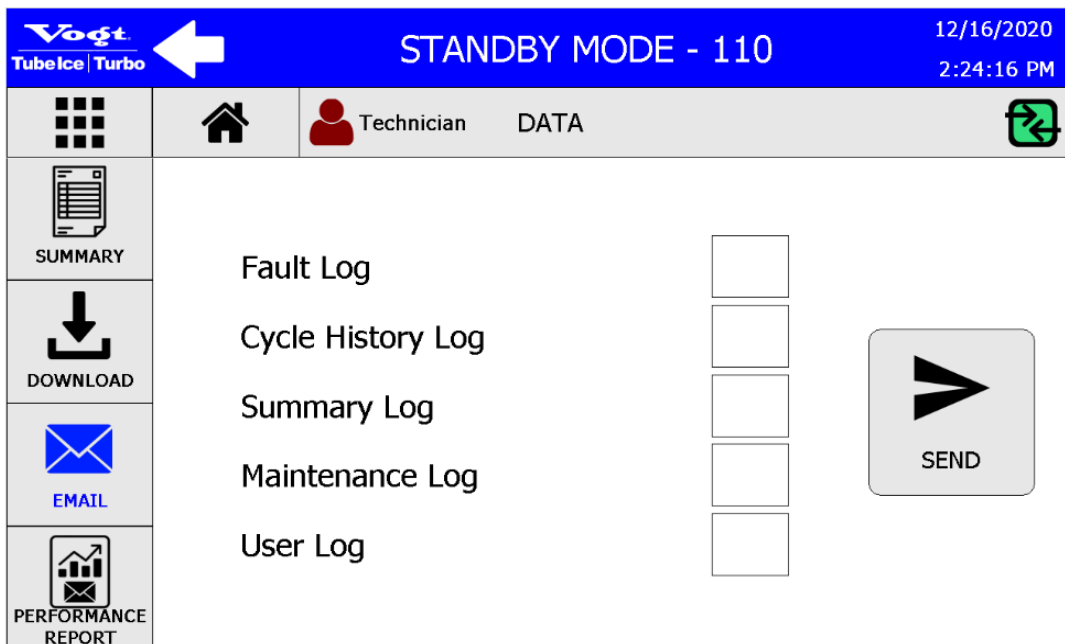

Figure 41: Email

A **PERFORMANCE REPORT** can be generated for each of the options listed in the **Select** window. Select the desired report and press

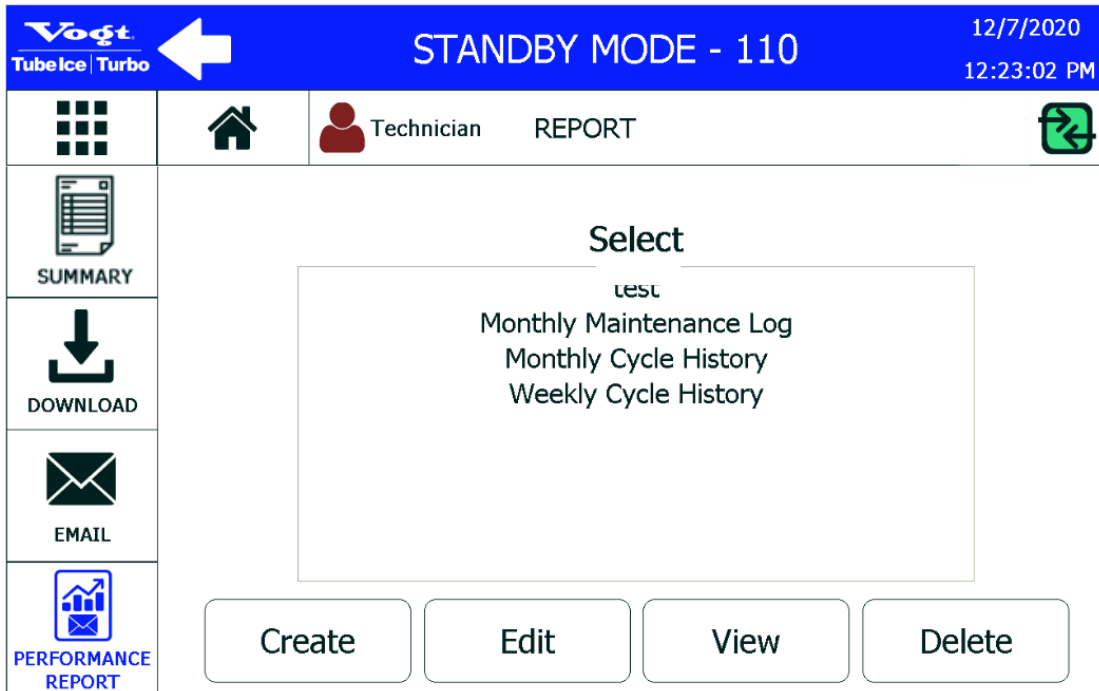

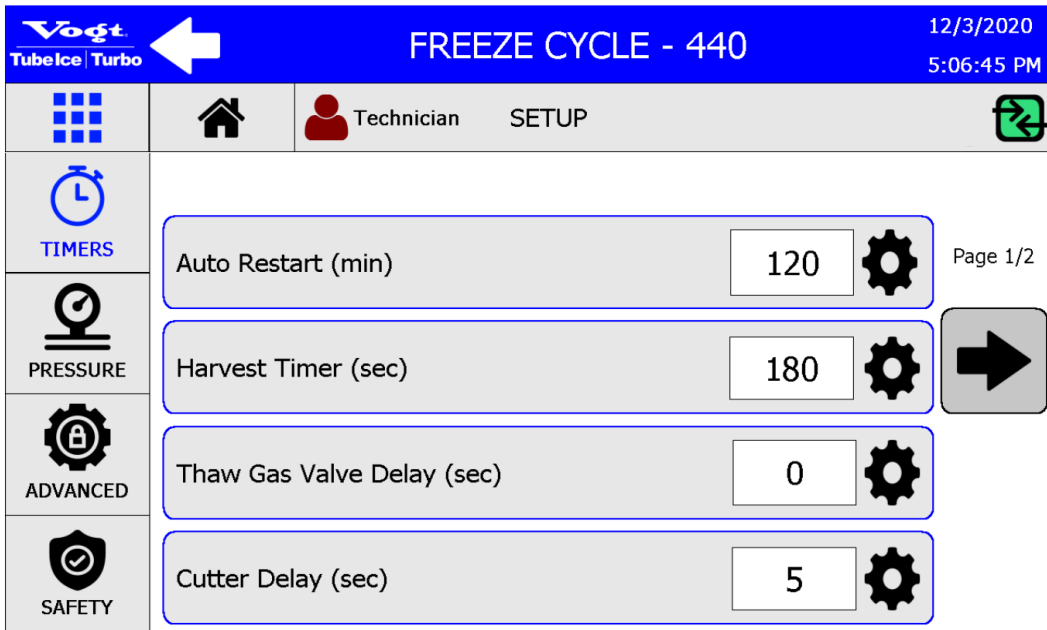

Figure 42: PERFORMANCE REPORT

The **SETUP** screen, Figure, allows the operator to adjust all of the parameters of the machine. Using the touch screen, select the gear icon  next to the parameter to be changed and follow the prompts on the screen to adjust the value. Use the arrow buttons  to access other pages within the submenus. See 43 through **Figure 9**.



Voegt Tubelce Turbo | **STANDBY MODE - 110** | 12/7/2020 11:30:44 AM

Technician SETUP

TIMERS | Freeze Timer (mm:ss) | 15 | 00 | Page 2/2

PRESSURE | Partial Pumpdown Timer (min) | 5

ADVANCED | Conveyor Delay at beginning of Harvest (sec) | 180

SAFETY | Conveyor Run Timer (sec) | 120

Figure 43: TIMER Settings

Voegt Tubelce Turbo | **STANDBY MODE - 110** | 12/7/2020 2:18:41 PM

Technician SETUP

TIMERS | Thaw Gas Cycle ON (PSI) | 35 | Page 1/2

PRESSURE | Thaw Gas Cycle OFF (PSI) | 45

ADVANCED | Fan Cycling Pressure OFF (PSI) | 140

SAFETY | Fan Cycling Pressure ON (PSI) | 155

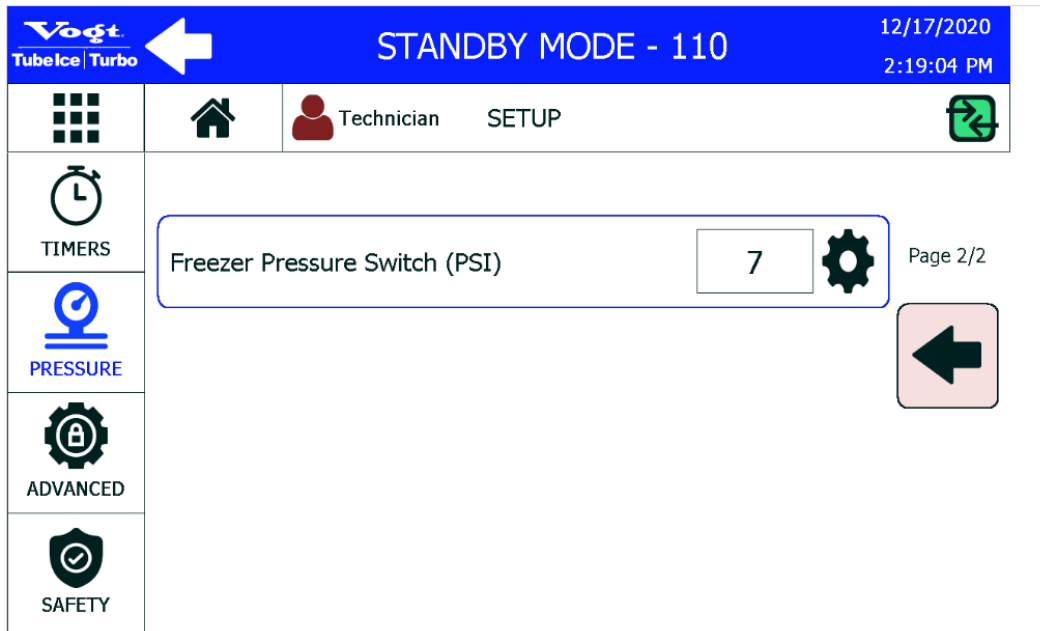

Figure 44: PRESSURE Settings

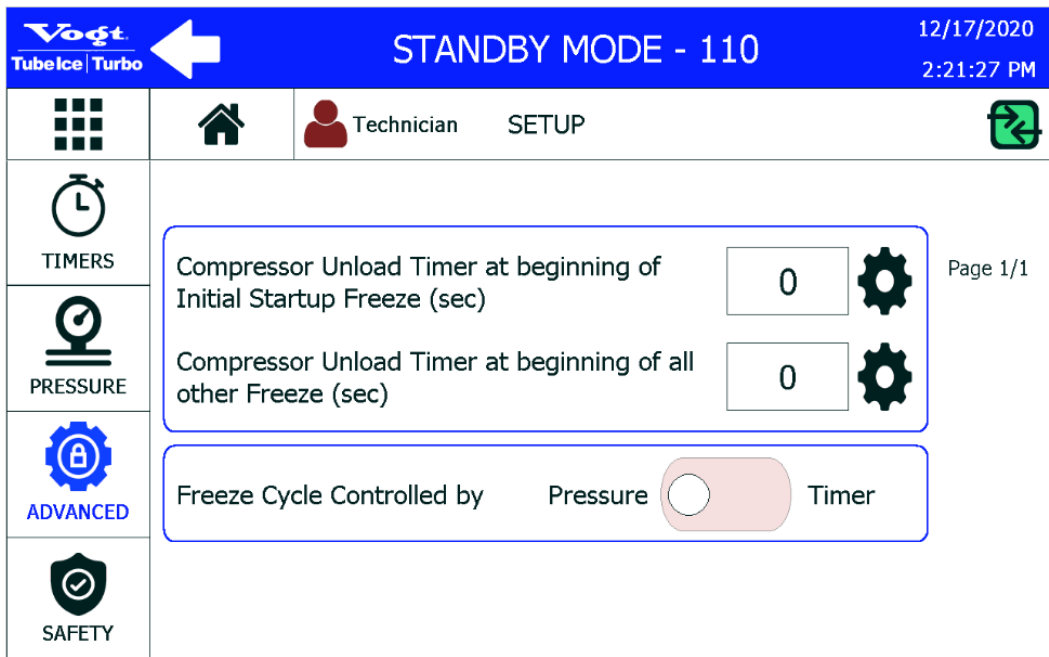

Figure 45: ADVANCED Settings

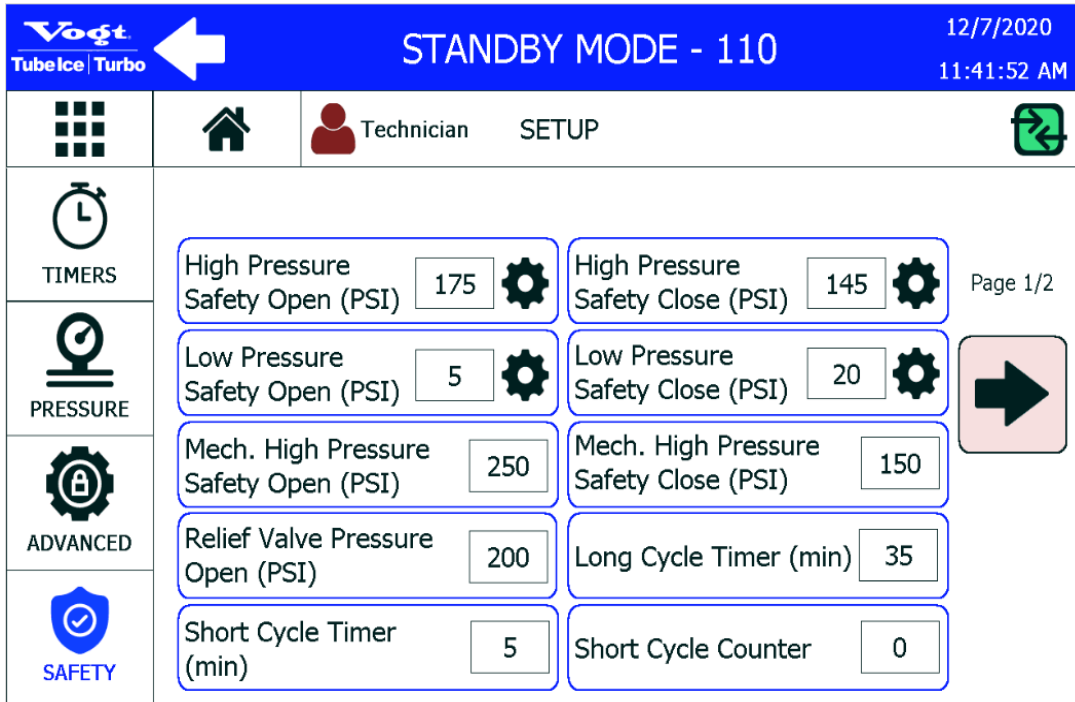

Figure 46: SAFETY Settings

The **CLEAN** screen, Figure, allows the operator to enter the cleaning mode of the machine. Refer to Chapter 7 for details on the cleaning process and the menu screens.

The **TROUBLESHOOTING** screen, Figure, allows the operator to perform maintenance and service functions. From the **PUMPDOWN** submenu, press the **Enable Maintenance Mode** touch screen button to access the machine maintenance functions. Refer to Chapter 9 for additional information on the **PUMPDOWN** submenu.

Press the **LOG** touch screen button to view records of actions that operators have taken on the machine. The **CREATE MAINTENANCE NOTE** touch screen button allows the operator to enter a separate note about service operations that have been performed, such as an oil change. See Figure 47.

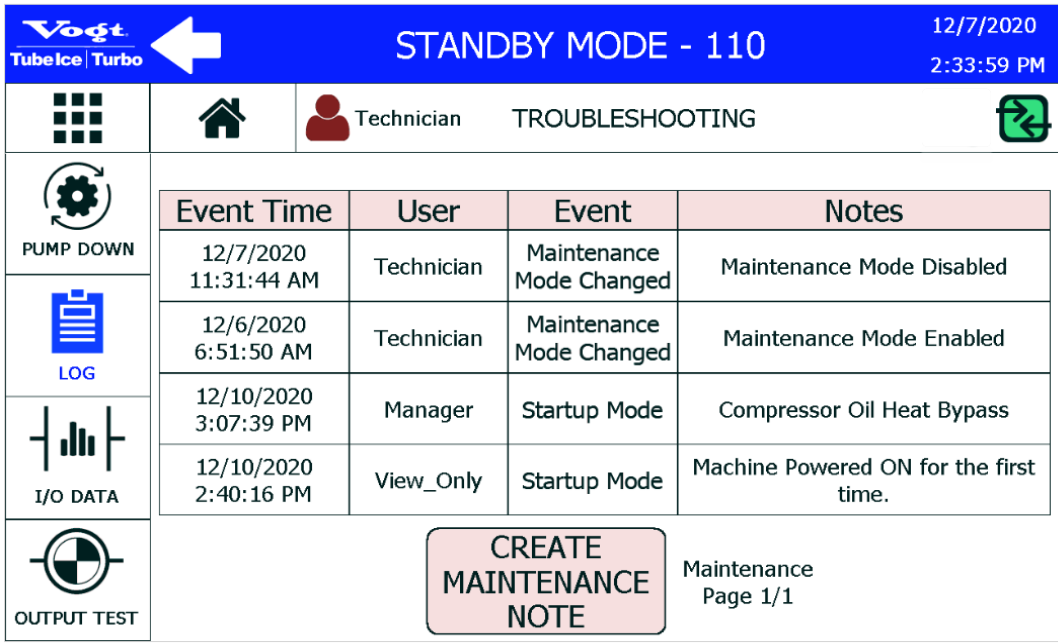

Figure 47: LOG Screen

Press the **I/O DATA** touch screen button to view the number of cycles and total run time for each input and output. See Figure 48.

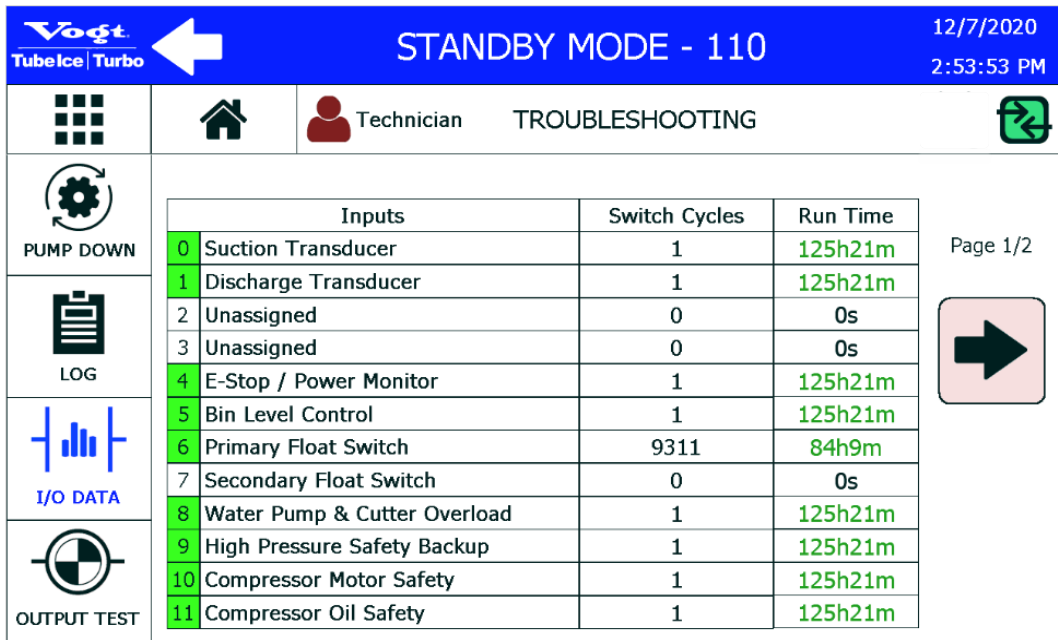

Figure 48: I/O DATA Screen

The **OUTPUT TEST** screen allows the user to turn on individual outputs to check for proper operation. Press the button next to the output to test. Press the gear icon to change the duration that the output is turned on. See Figure 49.

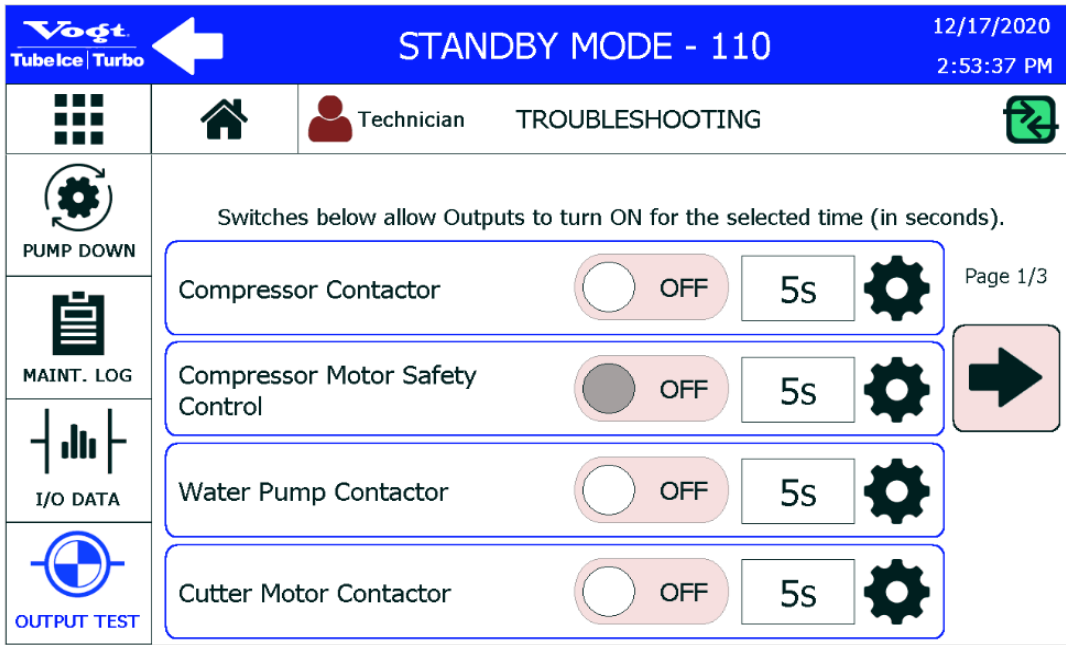

Figure 49: OUTPUT TEST Screen

The **FAULT** screen, Figure, displays the historical fault data for the machine. The last 20 fault records are stored.

The **INFO** screen, Figure, displays basic information about the ice machine. Press the **DOCUMENTS** touch screen button to access the machine service manual and specification sheet. Pressing the touch screen buttons will open the document within the HMI. See Figure 50.

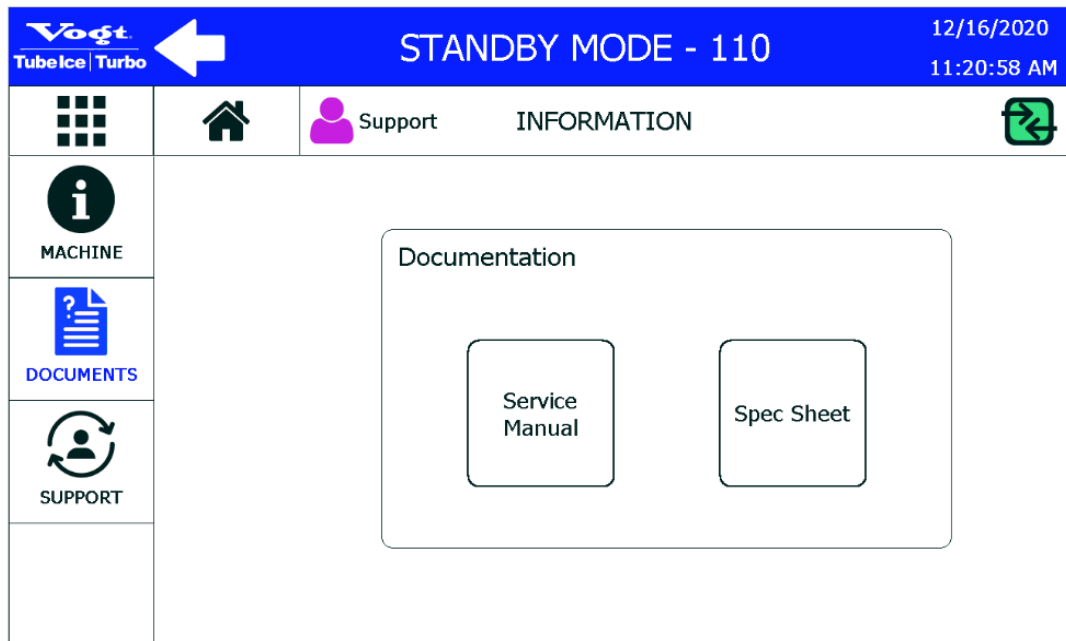

Figure 50: DOCUMENTS Screen

Press the **SUPPORT** touch screen button to display the contact information for Voegt SuperCare Technical Support and Parts. See Figure 51.

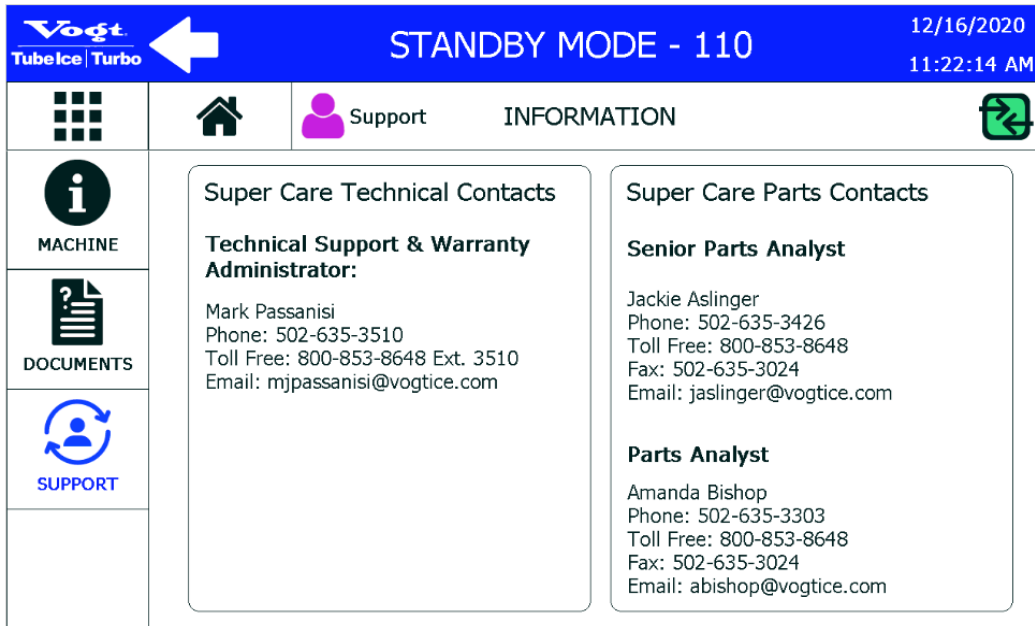

Figure 51: SUPPORT Screen

The **SYSTEM** screen, Figure, provides access to machine user groups and remote access capabilities. To enable **Fault Notifications** or **Maintenance Notifications** to be sent by email, press the button next to **EMAIL**.

Press the button next to **Remote Access** to enable remote users to connect to the machine.

Note: The machine must be connected to the Internet to enable email and remote access capabilities.

To return the machine to the factory settings, press the **Default Settings** touch screen button.

Press the **USERS** touch screen button to set up user groups for the machine, if desired. See Figure 52. Four user groups are available:

- Operator
- Technician
- Manager
- Voegt

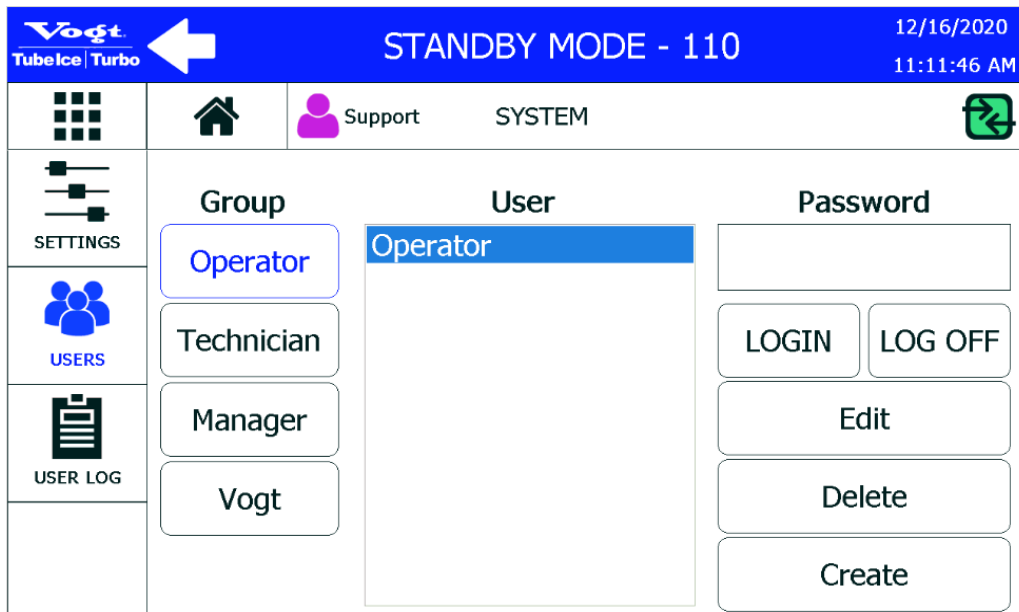

Figure 52: USERS Screen

To log in as a specific user, follow these steps:

1. Select the **Group** and the **User** to log in.
2. Press anywhere in the **Password** box and enter the **User** password.

Specific users can be added to each group. To add a user, follow these steps:

1. Select the **Group** touch screen button for the new user.
2. Press the **Create** touch screen button and follow the prompts to set up a new name and password. The new name will appear under the **User** section of the screen.

To edit the permissions of a specific user or group, follow these steps:

1. Log in as a specific user according to the instructions above.
2. Press the **Edit** touch screen button.
3. Select the desired permissions and settings for the user according to the prompts.

Press the **USER LOG** touch screen button to access records of the users that have accessed the system. See Figure 53.

Event Time	User	Event
12/16/2020 11:08:39 AM	Support	Logged In
12/16/2020 11:08:38 AM	Manager	Logged Out
12/16/2020 11:06:24 AM	Manager	Logged In
12/16/2020 11:06:23 AM	Operator	Logged Out

Page 1/1

Figure 53: USER LOG Screen

Control Panel Details

The control panel contains additional components that allow the machine to operate properly. Table 10 explains these components and their functions.

Table 11: Control Panel Component Functions

Component	Function
AX	Auxiliary trip indicator for manual motor starters. Switch opens, turning off the motor when cutter or pump motor starter trips.
CB	Overload and short circuit protection for control circuit and crankcase heater. (400/460V machines only)
C	Provides power to the compressor motor. Continuously energized during freezing and thawing. Auxiliary contacts control main power for control circuit components, crankcase heater, control relay, and harvest timer.
CU	Fan motor starter (manual motor starter and contactor). Starts and stops cutter motor. Provides short circuit and over current protection. Stops cutter motor and ice machine in the event of a mechanical or electrical malfunction that results in excessive motor amperes.
E-STOP	Emergency Stop button. When pressed, the button lights and power to the PLC outputs is removed, shutting machine off. Note: Power to the PLC & Touch Screen HMI will remain ON. The button must be manually reset (twist) and the E-Stop fault reset on the Touch Screen.
FC	Fan Control motor starter (manual motor starter and contactor). Cycles the fan motor(s) of air-cooled condenser on and off. Automatically activated by the PLC (air-cooled machines only). Provides short circuit and over current protection. Stops fan motors in the event of a mechanical or electrical malfunction that results in excessive motor amperes.
FU01&02	Overload and short circuit protection for the control circuit transformer.
FU-HMI & PLC	Short circuit protection for Touch screen HMI & PLC
FU-Y0 to Y10	Short circuit protection for PLC outputs
HMI	Touch Screen. Allows you to control the ice machine. This device allows you to view and/or input machine operating parameters, view machine cycle, maintenance, fault history, etc.
P	Pump motor starter (manual motor starter and contactor). Starts and stops pump motor. Provides short circuit and over current protection. Stops water pump motor in the event of a mechanical or electrical malfunction that results in excessive motor amperes.
PLC	Programmable Logic Controls. Controls all sequencing operations of the ice machine.
TB1	Low Voltage terminal block, is for 24VDC & 5VDC connections. Used primarily for PLC Input device, sensor & switch connections. Allow for component wire connections and ease of troubleshooting.
TB2	Main Control Voltage terminal block is for 120/240V control circuit components. Used primarily for PLC Output connections. Allow for component wire connections and ease of troubleshooting.
TB3	Customer Connection terminal block, is of water pump, cutter motor and compressor interlock connections.



Maintenance

To achieve the best performance from the HFO10, follow the maintenance instructions listed in this chapter. For questions concerning the maintenance or upkeep of your equipment, contact Vogt Ice, LLC.

Cleaning

The ice-making section of the Tube-Ice® machine should be cleaned at least twice a year (more often if water conditions cause mineral build-up). Use an approved food-grade ice machine cleaner. The machine is equipped with a cleaning mode, which circulates the cleaning solution through the freezer to remove mineral scale using the water pump. Detailed instructions are also attached to the machine.

To clean your Tube-Ice® machine, follow these steps:

1. Press the **HOME** touch screen button  to return to the **HOME** screen. Turn off the machine by pressing the **OFF** button on the **HOME** screen. Allow the machine to cycle off.
2. Press the grid touch screen button  to return to the **MENU** screen. press the **CLEAN** touch screen button to access the cleaning submenu. See Figure 54.

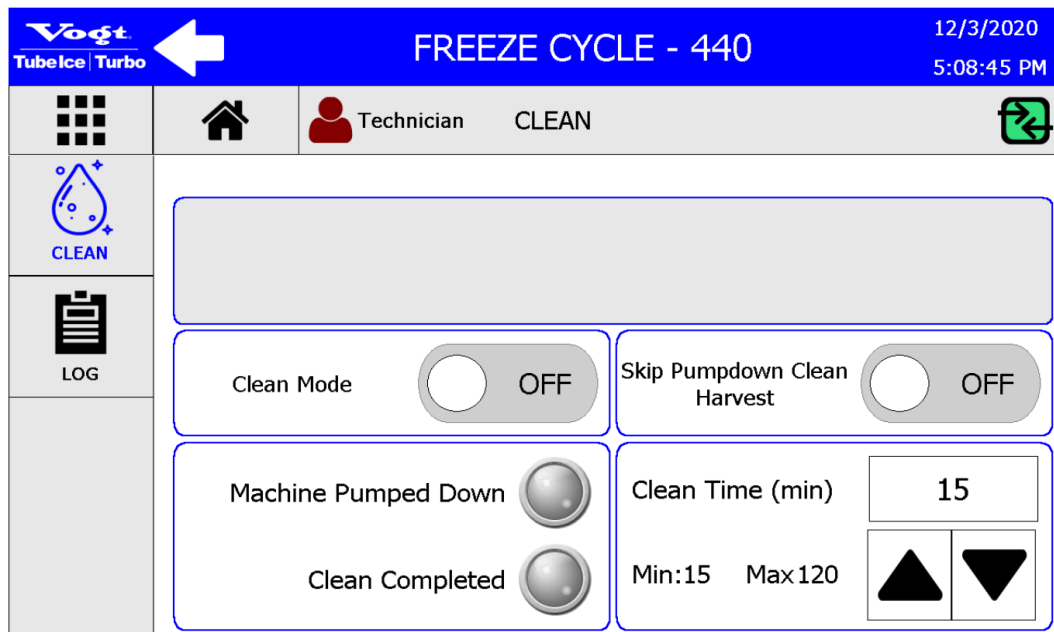



Figure 54: CLEAN Screen

3. Select the amount of time to clean the machine by pressing the arrows  in the **Clean Time** section of the screen. The cleaning cycle time can be set from 15 minutes to 120 minutes.
4. Remove ice from the storage area or cover the storage opening.
5. Shut off the water supply and drain the water tank by opening the drain valve. Remove any loose sediment from the tank.
6. Close the drain valve and fill the water tank with warm water. Close the petcock valve on the water pump during the cleaning period. The tank holds approximately 15 gal (57 L).
7. Add the ice machine cleaning solution to the water tank according to the directions of the cleaning solution manufacturer. Vogt recommends Nu-Calgon® Ice Machine Cleaner, which is a food-grade liquid phosphoric acid.
8. Inspect the water distributors by looking through the transparent freezer cover. It may be necessary to clean the cover before inspecting. If required, remove the cover. Clean and remove any solid particles from the two orifices in each distributor. Clean the rubber cover gasket and reinstall the cover.

9. Press the button next to **Clean Mode** to enter the cleaning mode. The machine will begin with a pumpdown cycle. The operator can choose to bypass the pumpdown harvest cycle by pressing the button next to **Skip Pumpdown Clean Harvest**.
10. After the machine has pumped down, the icon next to **Machine Pumped Down** will turn blue, the compressor will turn off, and the water pump will begin circulating the cleaning solution. See Figure 55.

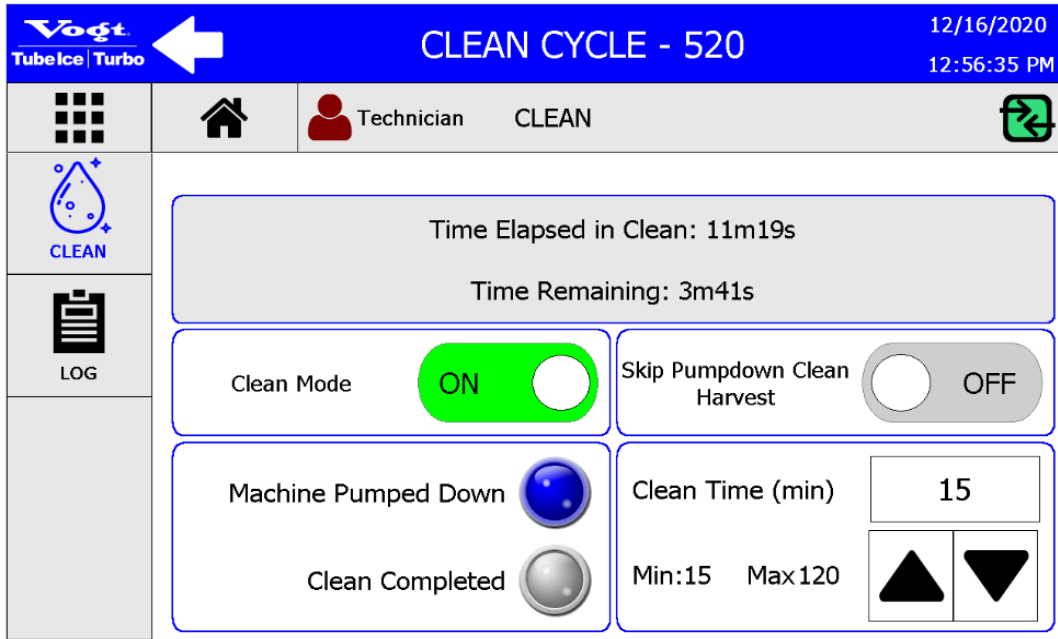

Figure 55: CLEAN Screen – Machine Pumped Down

11. When the machine has completed a cleaning cycle, the icon next to **Clean Completed** will turn blue and the machine will automatically turn off the **Clean Mode**. See Figure 56. Repeat cleaning if necessary.

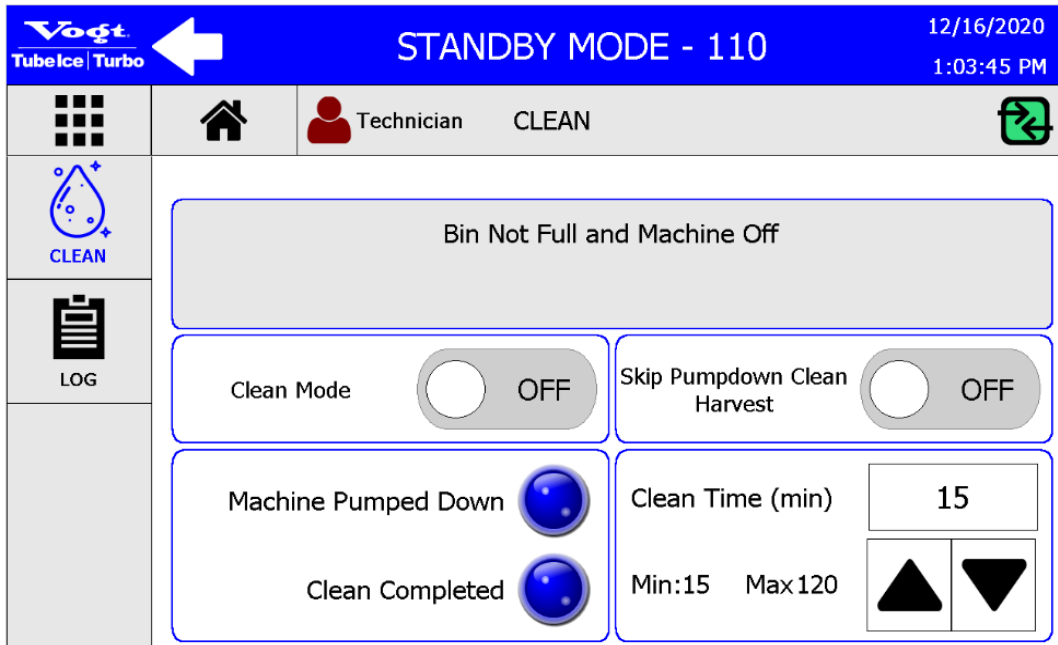



Figure 56: CLEAN Screen – Clean Completed

Note: To exit the cleaning mode at any time during the cleaning cycle, press the button next to **Clean Mode**.

12. After the cleaning cycle is complete, drain and flush the water tank with fresh water.

13. Open the water supply to the machine.
14. Drain, flush tank again, and refill it with fresh water.
15. Clean the inside of the ice storage area and remove any solution that entered during the cleaning process. Remove the cover, if one was installed, over the opening into the storage area.





To return the machine to ice-making operation, follow the steps below:

1. Make sure the water tank drain valve is closed.
2. Turn on the water supply and refill the tank with clean water.
3. When the water tank is full, press the **HOME** touch screen button  to return to the **HOME** screen.
4. Press the **ICE** touch screen button to start the machine. The PLC automatically opens the liquid feed valve briefly to re-pressurize the evaporator. No additional action, such as valve adjustment, is required by the operator.
5. Once the evaporator has re-pressurized automatically, the machine will immediately resume normal operation.

Check that the adjustable blowdown petcock valve on the recirculating water pump is adjusted properly. The valve should be adjusted to the minimum rate required to maintain production of clear ice. This should be no more than 1 gal (3.8 L) per minute for most water sources.

Sanitizing

To sanitize your Tube-Ice® machine, follow these steps:

1. Press the **HOME** touch screen button  to return to the **HOME** screen. Turn off the machine by pressing the **OFF** button on the **HOME** screen. Allow the machine to cycle off.
2. Press the grid touch screen button  to return to the **MENU** screen. Press the **CLEAN** touch screen button to access the cleaning submenu. See Figure 17.
3. Select the amount of time to clean the machine by pressing the arrows   in the **Clean Time** section of the screen. The minimum suggested cycle time for sanitizing is 30 minutes.
4. Remove ice from the storage area or cover the storage opening.
5. Shut off the water supply and drain the water tank by opening the drain valve. Remove any loose sediment from the tank.
6. Close the drain valve and fill the water tank with warm water. Close the petcock valve on the water pump during the cleaning period. The tank holds approximately 15 gal (57 L).
7. In a clean container, mix 15 gal (56.8 L) of warm water at 90°F–115°F (32°C–46°C) with 24 oz (0.71 L) of Nu-Calgon® IMS-II Sanitizing concentrate (or equivalent, according to the manufacturer's instructions). The concentration should be 200 parts per million (ppm) (8 oz [227 g] per 5 gal [18.9 L]) of active sanitizing solution.
8. Close the drain valve and fill the water tank with the sanitizing solution.
9. Close the adjustable blow down petcock valve on the water pump.
10. Press the button next to **Clean Mode** to begin sanitizing the machine. The machine will begin with a pumpdown cycle. The operator can choose to bypass the pumpdown harvest cycle by pressing the button next to **Skip Pumpdown Clean Harvest**.
11. Mix an additional 5 gal (18.9 L) of warm water at 90°F–115°F (32°C–46°C) with 8 oz (227 g) of Nu-Calgon® IMS-II Sanitizing concentrate (or equivalent, according to the manufacturer's instructions) in the clean container. The concentration should be 200 ppm of active sanitizing solution.
12. Wearing appropriate gloves, submerge a clean sponge in the sanitizing solution and wipe all inside surfaces of the water tank and tank cover, including the makeup water float valve.
13. With the water pump running, add the additional 5 gal (18.9 L) of sanitizing solution to the water tank. Install the water tank cover and allow the sanitizing solution to circulate for at least 20 minutes.

14. While circulating the sanitizing solution, open the adjustable blow down petcock valve and allow the solution to flow down the drain. With the petcock valve open, allow the water to circulate for at least 3 minutes.
15. When the machine has completed a sanitizing cycle, the icon next to **Clean Completed** will turn blue and the machine will automatically turn off the **Clean Mode**. See Figure 27.
16. Drain and flush the water tank with fresh water.
17. Open the water supply to the machine.
18. Drain, flush tank again, and refill with fresh water.
19. To sanitize the inside of the ice storage area, flood the area with the sanitizing solution, making sure to wet all surfaces completely for at least 60 seconds. The concentration should be 200 ppm of active sanitizing solution.

To return the machine to ice-making operation, follow the steps below:

1. Make sure the water tank drain valve is closed.
2. Turn on the water supply and refill the tank with clean water.
3. When the water tank is full, press the **HOME** touch screen button  to return to the **HOME** screen.
4. Press the **ICE** touch screen button to start the machine. The PLC automatically opens the liquid feed valve briefly to re-pressurize the evaporator. No additional action, such as valve adjustment, is required by the operator.
5. Once the evaporator has re-pressurized automatically, the machine will immediately resume normal operation.

Check that the adjustable blowdown petcock valve on the recirculating water pump is adjusted properly. The valve should be adjusted to the minimum rate required to maintain production of clear ice. This should be no more than 1 gal (3.8 L) per minute for most water sources

Water Distributors

The water distributors are located under the freezer cover at the top of the freezer. These distributors may require occasional or periodic cleaning to remove solids and foreign particles accumulated from the makeup water. The frequency of this cleaning operation will depend on the characteristics of the water supply (refer Vogt Ice's water quality bulletin). The cleaning operation is needed when:

- Inside diameter of a large proportion of the ice becomes irregular
- Some of the ice is opaque
- There is a notable decrease in ice capacity

To clean the water distributors:

1. Shut down the machine and remove the freezer cover on the top of the freezer.
2. Remove the water distributors (one per tube) with pliers.
3. Use the pliers on the top part of the distributor with a twisting upward motion, taking care not to damage the orifices or the distributor body.
4. Soak the distributors in ice machine cleaner to remove mineral buildup if needed.
5. Rinse distributors thoroughly before reinstalling, tapping them in lightly with a rubber mallet to seat them in the freezer tubes.

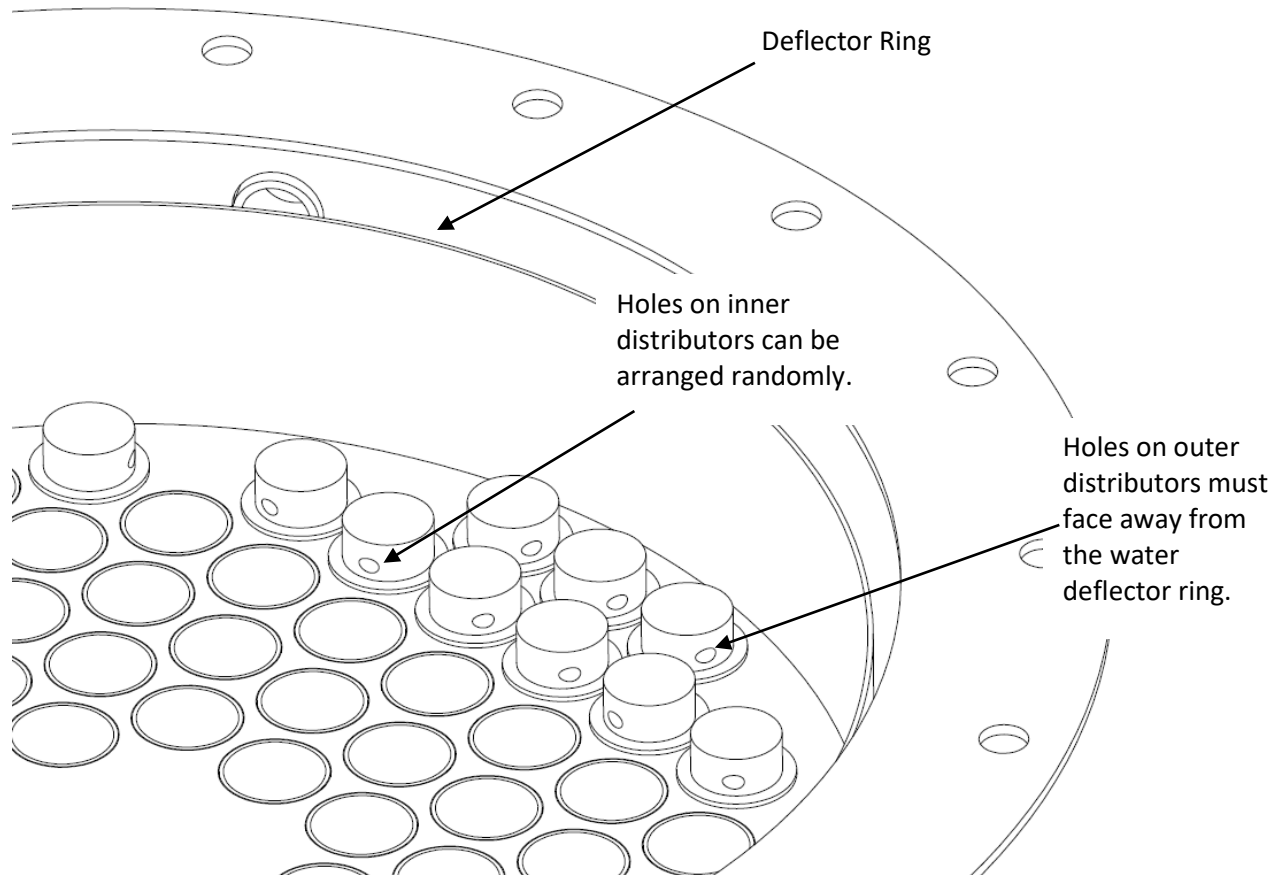

Figure 57: Water Distributor Detail

Table 8 shows the part numbers and tube quantities for water distributors on the HFO10.

Table 12: Water Distributor Information

Tube Size in. (mm)	Number of Tubes	Vogt Part Numbers		
		Water Distributor	Freezer Cover	Freezer Cover Gasket
1 (25)	156	12B2185N11	12B2145C03	12A2600G15
1-1/4 (32)	102	12B2185N21		
1-1/2 (38)	72	12B2185N31		

Water Tank

The production of opaque ice indicates the water in the water tank contains a concentrated number of solids or salts. To remedy this problem, follow the steps below:

1. Shut down the machine.
2. Remove the cover plate on the water tank and open the drain valve.
3. Clean the tank thoroughly by flushing it out with a hose and scrubbing it with a stiff brush. It may be necessary to completely remove the water tank in order to clean all internal surfaces.
4. After cleaning, reinstall the tank if necessary, close the drain valve, and fill the tank with fresh water.
5. Press the **HOME** touch screen button  to return to the **HOME** screen and press the **Run Pump** touch screen button to check if the pump is working properly. Air may have collected in the impeller housing, and the pump may have to be stopped and started several times to expel this air.
6. After the pump is checked for proper flow, press the **Run Pump** touch screen button to turn the pump off.
7. Press the **ICE** touch screen button to resume ice production.

Freezer Cover

A clear polycarbonate freezer cover is provided for visual inspection of the water box and water distributors located at the top of the freezer. The cover should be removed and cleaned if it becomes coated with deposits. Generally, if this cover is coated with solids, this is a major indicator that other water contact areas (i.e., water tank and distributors) also require cleaning.

Water-Cooled Condensers

The interval in which condensers require cleaning varies. Some installations seldom need cleaning, while others may require cleaning at least once a year or even several times a year.

Proper operation of cooling towers increases the interval between cleaning considerably. Check the tower overflow rate frequently. If a tower operates with insufficient overflow (nominal 1.5 to 3 gph [5.7 – 11.4 Lph], depending on water quality), the resulting mineral concentration in the water can cause rapid and heavy fouling inside the condenser tubes, requiring excessively frequent cleaning. Also, these conditions often lead to severe corrosion.

Chemical additives, including those used to stop algae and related growths, should be obtained only from a reputable, established supplier. Always follow manufacturer's directions. Excessive treatment of the water can cause more harm than good, and the condensers, pumps, piping, and towers themselves may be damaged.

Double check the system to make sure that fouling is actually causing the trouble. High head pressure alone does not mean a fouled condenser.

Before cleaning, always check for the following conditions:

- Non-condensables in the system or a faulty head pressure gauge—Check standby pressures against refrigerant tables.
- Incorrectly set or defective water regulator valve—Check setting and operation.
- Partly closed compressor discharge service valve—Check the stem position to confirm that it is backseated.
- High-temperature water entering the condenser. Check the cooling tower fan and system.

If none of these problems exist, or they have been resolved, determine the temperature difference between the water leaving the condenser and the refrigerant condensing temperature (saturation temperature [refer to Table 26: Pressure-Temperature Chart], corresponding to the head pressure). If this difference exceeds 10°F (5.6°C), cleaning is required because the difference indicates that good heat transfer is not occurring.

If the difference is less than 8°F (4.5°C), something other than a fouled condenser may be the cause of high head pressure. During normal operation, the temperature difference stays between 5°F and 10°F (2.8°C and 5.6°C) regardless of water inlet temperature, when the water flow is regulated by a pressure-operated water valve. If the difference is less than 5°F (2.8°C), restricted water flow or a low supply pressure is likely. A restriction can be caused by foreign matter in the condenser, but it is likely to be elsewhere in the system.

Draining

Draining of water-cooled condensers is recommended in climates where units may be left exposed to ambient temperatures below 32°F (0°C). Although condensers usually have a vent and drain fittings, the opening of these fittings is not sufficient for a natural gravity flow of water. Water is thus retained in the tube due to the surface tension between the tube and the water and the normal curvature between tube supports.

Experience shows that as much as 20% of the water in the condenser is retained. To break the surface tension between the water and the tubes and to drain all tubes completely, the condenser must be tilted a minimum of 5 degrees. Whether water left in the tubes causes damage depends on how quickly the water freezes and its location inside the condenser. Condenser manufacturers recommend that each tube is blown out individually with compressed air to remove the water. Alternatively, a minimum of 25% ethylene glycol in the system will also prevent the water from freezing, which can rupture the tubes.

Chemical Cleaning

Vogt Ice, LLC, makes no recommendation for any particular chemical preparation because the same chemical may not be effective in all circumstances.

CAUTION

The warranty on condensers is void if they are damaged by improper cleaning tools or methods. If harsh chemicals are used, be sure to follow the manufacturer's recommendations regarding safe handling of those solutions.

Follow these directions and precautions when cleaning:

- Use only preparations from an established, reliable source.
- Follow directions exactly, particularly regarding amounts to use, and flushing or neutralizing procedures after cleaning.
- Close the water supply to the stop valve and remove the condenser water regulating valve.
- Circulate the solution through the condenser until it is considered clean (no excess scale on tubes or tubesheets).
- Flush the condenser according to the directions provided by the chemical manufacturer.
- Reinstall the water regulating valve and associated piping.
- Open the water-supply stop valve and check for leaks.

Mechanical Cleaning

The following steps should be followed during mechanical cleaning.

1. Close the stop valve in the water supply line.
2. Drain the water from the condenser.
3. Remove the water regulating valve and associated piping from the condenser.
4. Remove the nuts, water plates, and gaskets from both ends of the condenser.
 - If the gasket does not lift off with the end plate, do not attempt to pry it off. This can damage the sealing surface, causing a water leak. To free a sticking gasket, replace the water plate and tap the outside face of the plate with a rubber mallet or block of wood. After a few taps, the gasket will spring free and slip off with the water end plate.
5. Rinse gaskets with running water and use a rag or soft brush to remove foreign matter.
 - Rust, scale, and dirt will not stick to the gasket material.
6. Use clean water and a rag or soft bristle brush to clean the inside of the water end plates and the outer tube sheet surfaces.

Note: Never use a wire brush or strong caustic on these surfaces.

 - These surfaces have been coated with a special material that will give years of protection against corrosion unless damaged.
7. Flush the condenser tubes clear with air, water, or a piece of rag on the end of a stick or wire. This will sufficiently clean the tubes in many cases.
 - If the inside surfaces are smooth, further cleaning is not necessary, even though the surfaces may be discolored. Do not attempt to achieve a bright copper finish on the tubes as they will quickly discolor when in service. The condenser is designed to handle moderate fouling on these surfaces.
 - If a rough coating remains on the insides of the tubes after flushing and wiping, further cleaning is required. The color will vary depending on water conditions. In these circumstances, use a nylon, brass, or copper brush to clean the tubes. Do not use any tool that will score, mark, flake, or otherwise cut into the tubes.

Compressor Lubrication

The HFO10 is built with the industry leading semi-hermetic Bitzer Compact Screw Compressor (CSH). This robust and energy-efficient compressor requires a special synthetic refrigeration compressor oil to reduce friction, the Bitzer BSE 170 oil.

When starting and charging the unit, the oil in the sight glass of the compressor crankcase should be watched carefully for the first hour to ensure that the proper amount of oil is remaining in the crankcase (between the lines on the sight glass). The oil level may be low on initial start-up if electrical current to the crankcase heater was interrupted.

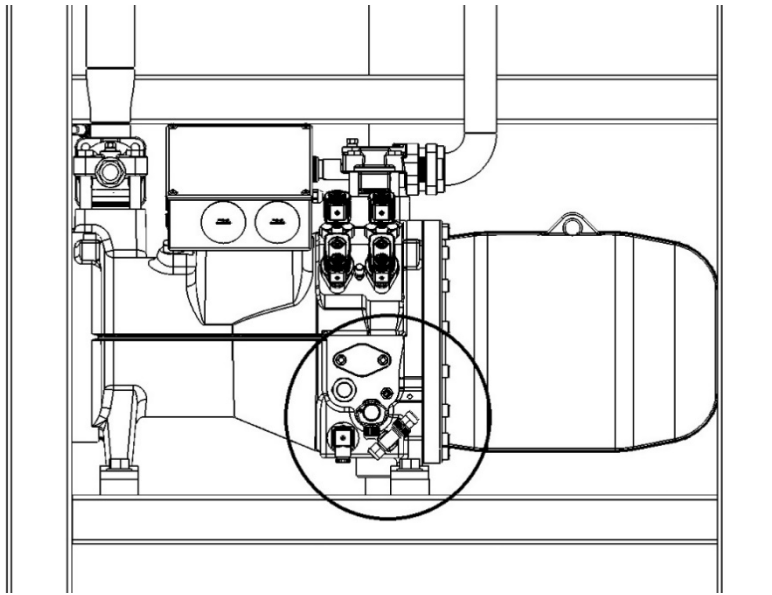

Figure 58: Front of the Machine - Compressor Section

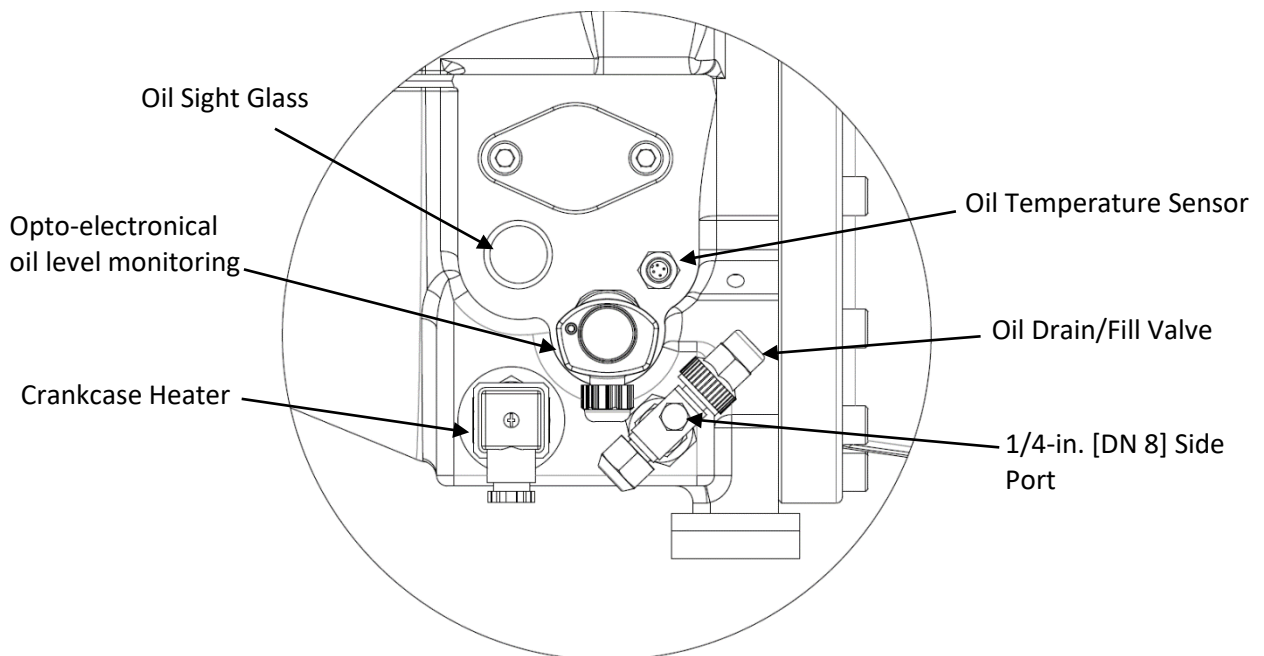

Figure 59: Compressor Oil Section

If there is a power interruption to the crankcase heater, the heater should be energized for at least two hours before restarting the machine. This allows for evaporation of refrigerant that may have condensed in the crankcase during the shutdown period. If the level is low after start-up, it should begin to return after a short period of operation.

The oil level should be checked frequently, particularly during the start-up operation, to make sure a sufficient amount of oil remains in the crankcase. While it is important to observe the oil splash during operation, the true level can be obtained only when the compressor is stopped. With the compressor idle, the oil level should be at a height of 1/4 to 3/4 of the sight glass but never out of sight above it.

The machine is shipped with the proper amount of oil for operating water-cooled systems. However, it may become necessary to add some oil if new refrigerant is added to the system at a later date. Generally, air-cooled machines will require additional refrigerant and oil to compensate for long piping runs to the condenser.

The tables below detail the type of oil required for the HFO10's screw compressor. Using any other types of oil will void the machine warranty.

Table 13: Required Compressor Lubricants and Capacity

Refrigerant	Required Lubricants	Lubricant Type	Water-Cooled Oil Charge oz (ml)
R-513A	Bitzer BSE 170	Polyol Ester Oil	305 (30)

Note: The oil specified for this machine is very hygroscopic (it attracts and holds water molecules from the surrounding environment) and should be protected from the atmosphere to all extents possible.

If the compressor needs more oil, use an oil pump. To add oil, remove the large refrigerant valve cap on the Oil Drain/Fill valve in Figure 27. Backseat the valve (large stem out) to close off the 1/4-in (DN 8) side port on the valve body. Remove the 1/4-in. (DN 8) brass seal cap to access the oil fill port on the valve body. Once the seal cap is removed, connect a refrigerant hose to the 1/4-in. (DN 8) port and front seat the valve (large stem in) to open the 1/4-in. (DN 8) port. Using an oil pump, add oil directly to the compressor crankcase until the oil reaches the oil fill mark on the side of the compressor body.

After all oil is added, backseat the valve (large stem out) to close off the 1/4-in. (DN 8) side port on the valve body, remove the refrigerant hose, and replace the 1/4-in. (DN 8) brass seal cap. Front seat the valve (large stem in) and check for leaks at the brass seal cap. If no leaks are found, replace the large refrigerant valve cap on the Oil Drain/Fill valve.

The Bitzer screw compressor is equipped with an opto-electronical oil level sensor, which monitors the compressor's oil level and automatically stops the machine if the oil level is too low. This helps avoid damage to the compressor.

For other compressor maintenance procedures, refer to the Bitzer service bulletin SB-170 operating manual.

Lubrication of the Cutter Motor Gear Reducer

The oil level for the gear reducer should be checked to see if a leak exists. The oil level should be at the bottom of the plugged opening in the side of the gear housing. Use Mobile 600W cylinder oil or equivalent. Change the oil once a year.

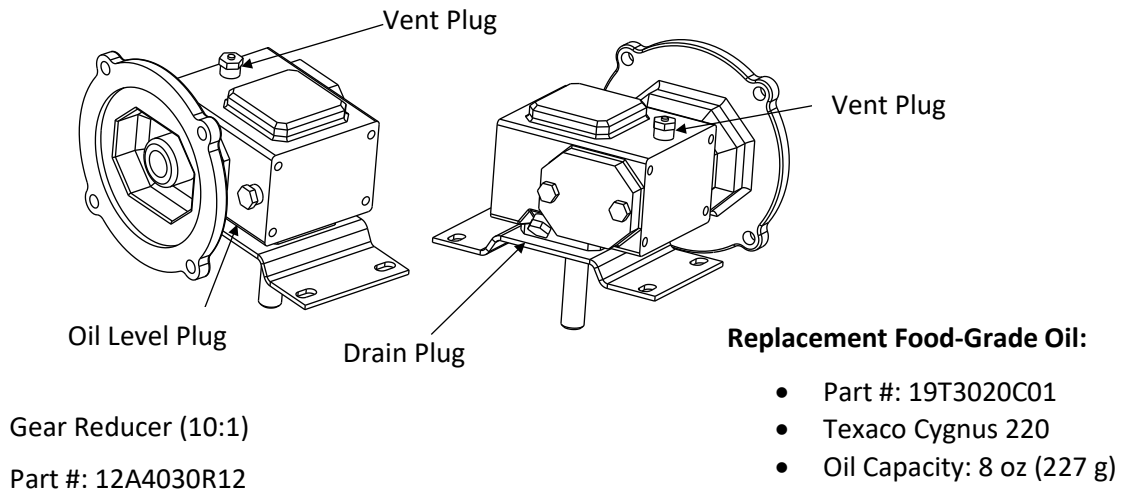

Figure 60: Cutter Motor Gear Reducer

Preventive Maintenance

A preventive maintenance program is recommended for optimum and efficient operation and a long service life. It is recommended that you or a delegated employee make a daily visual check of your Tube-Ice[®] machine. When you are aware of the proper operating conditions and observe them on a daily basis, changes in these conditions can alert you to changes in the operation of the machine that may require maintenance long before a service situation arises.

The following schedule is suggested as a minimum:

Daily Checklist

- Is the machine running, or is the bin full?
- Bin doors are closed.
- Thermostat bulb is in the bracket.
- All ice discharges during harvest period.
- Machine and components are clean.
- No unusual noises.
- Operating pressures (suction, discharge, hot gas, oil) are within acceptable limits.
- Ice quality (clarity and uniformity) is correct (refer to water conditioning bulletin).
- Harvest period continues at least 30 seconds after the last ice is out.
- Compressor oil level is appropriate.
- Refrigerant operation level is within acceptable limits.
- The frost pattern on the freezer shell extends to the bottom of the suction connection.
- Water float valve is properly adjusted (water should not pour out of the tank during operation or cause the water pump to cavitate).

Weekly Checklist

- Weekly or Monthly Calibration and operation of all controls (high- and low-pressure switches, oil pressure switch, etc.) are within limits.
- Cooling tower spray nozzles and pump suction screen are free of scaling and algae (consult water treatment suppliers for corrective measures).
- Water distributors at the top of the freezer are free of scale accumulation.
- Remove solids that have collected in the water tank.
- Check all motor drive units (compressor, pump motors, cooling tower fan, and pump, etc.) for abnormal noise and/or vibrations.
- Observe one complete ice making cycle, record data, and compare with the **Warranty Registration/Start-Up Form**.

Monthly or Yearly Checklist

- Check entire system for leaks.
- Check system for leaks after 400 hours or 4 weeks of operation.
- Drain water from the condenser and cooling tower and check condenser tubes. Inspect for damage by corrosion or scale.
- Remove all rust from all equipment, clean, and paint.
- Check all motors for shaft wear and end play.
- Check operation and general condition of all electrical controls, relays, motor starters, and solenoid valves.
- Observe one complete ice making cycle, record data, and compare with the **Warranty Registration/Start-Up Form**.
- Change oil in cutter motor gear reducer.



Warning: Pressure relief valves must be replaced after 5 years of service. Before replacing relief valves, review requirements per current local and national codes. Valve replacement should be performed only by service personnel experienced and certified in refrigeration and qualified to work with high-voltage electrical equipment. If a relief valve discharges, the valve must be replaced before putting the machine back into service. Relief valves do not properly reseal after a discharge event. Contact Vogt SuperCare Customer Service for replacement valves.

Preventive Maintenance Form

This form can be removed and duplicated for record keeping. This page is a complete Preventive Maintenance Schedule that should be performed every 90 days. The Preventive Maintenance page may be copied and given to your service person. It should be signed, dated, and returned to you for permanent record.

Date:

Model No.:

Serial No.:

The following service was performed and checked:

Service	
<input type="checkbox"/>	Last maintenance performed (approx. date) ____ / ____ / ____
<input type="checkbox"/>	Scale condition of water tank and tubes (good - fair - poor)
<input type="checkbox"/>	All drains freely draining (water tank, drip pan, ice bin)
<input type="checkbox"/>	Water distributors cleaned
<input type="checkbox"/>	Ice machine cleaner circulated through system
<input type="checkbox"/>	Condenser clean (water-cooled, if applicable)
<input type="checkbox"/>	Voltage at machine (actual reading) _____, _____, _____
<input type="checkbox"/>	Compressor amps (halfway through freeze cycle) _____, _____, _____
<input type="checkbox"/>	Cutter motor amps while cutting ice _____, _____, _____
<input type="checkbox"/>	Water pump amps while pump running _____, _____, _____
<input type="checkbox"/>	AC condenser motor amps (if applicable) _____, _____, _____
<input type="checkbox"/>	Crankcase heater heats oil
<input type="checkbox"/>	Refrigerant leaks (okay - high - low)
<input type="checkbox"/>	Leak-checked entire system; number of leaks found _____
<input type="checkbox"/>	Compressor oil level in sight glass (1/4 - 1/2 - 3/4 - low - high)
<input type="checkbox"/>	Gear reducer oil level (correct level - low level)
<input type="checkbox"/>	Low-pressure switch setting, psig _____
<input type="checkbox"/>	High-pressure switch setting, psig _____
<input type="checkbox"/>	Bin stat(s) installed and operating properly
<input type="checkbox"/>	Makeup water float valve adjusted properly (pump not cavitating, water tank not overflowing)
<input type="checkbox"/>	Adjustable blowdown adjusted for clear ice
<input type="checkbox"/>	Suction psig at end of freeze CYL _____ CRU _____
<input type="checkbox"/>	Suction psig during harvest (high / low) CYL _____ CRU _____
<input type="checkbox"/>	Discharge psig at end of freeze CYL _____ CRU _____
<input type="checkbox"/>	Ambient temperature at machine (°F/ °C)
<input type="checkbox"/>	Outside ambient temperature (at air-cooled condenser or cooling tower, °F/ °C)
<input type="checkbox"/>	Makeup water temperature (°F/ °C)
<input type="checkbox"/>	Freeze period time (minutes)
<input type="checkbox"/>	Harvest period time (minutes)
<input type="checkbox"/>	Total cycle time (Freeze period time + harvest period time, minutes)
<input type="checkbox"/>	First ice out time (seconds)
<input type="checkbox"/>	Last ice out time (seconds)
<input type="checkbox"/>	Ice weight per cycle (lb/ kg)
<input type="checkbox"/>	24-hour production capacity $\left(\frac{\text{Ice weight per cycle}}{\text{Total cycle time}} \times 1440 \right)$

Comments:

Signature:

Chapter 8 Troubleshooting



Warning: Only service personnel experienced and certified in refrigeration and qualified to work with high-voltage electrical equipment should be allowed to install or work on this Tube-Ice® machine.



Follow all lock-out and tag-out procedures before servicing any electrical equipment.

Note: With the exception of bin control, anytime the machine stops, it must be manually restarted by pushing the **Start** button. If the machine stops during a freeze period, it restarts in a thawing (harvest) period.

This section lists potential problems and suggests solutions for this Tube-Ice® machine. Some of the problems and solutions apply to optional equipment supplied by others and may vary. Many problems are easy to solve if you know what caused them. If your problem is not covered in this section, call the factory directly at 1-502-635-3000 or 1-800-853-8648.

Your machine's electrical system has several built-in safety and overload protection features to stop operation when a single component fails or there is a problem from an outside source, such as a power supply. Make sure all auxiliary equipment is connected to safety and overload circuits so all related equipment is protected.

Always check the machine thoroughly after addressing the problem to prevent the same cause from reoccurring.

Machine Not Running

Possible Causes	Possible Solutions
Power failure and intermittent power interruption	Check electrical fused disconnect or circuit breaker supplying power to the machine. If power has been off for a period of time, make sure the compressor crankcase heater is energized, the crankcase is warm (100 - 110°F [38 - 43°C]), and there is no liquid refrigerant in the crankcase before running the machine. Push Start to initiate startup in a thawing period.
3.0-amp circuit breaker in the control panel trips	Check compressor crankcase heater, coils of relays, contactors, starters, solenoid valves, and thawing timer for a ground. Repair or replace any defective part and replace fuse. Make sure there is no liquid refrigerant in the compressor crankcase before restarting the machine.
High/low safety pressure switch trips	If the machine stops because the pressure is too low, the switch resets automatically when the pressure increases to the appropriate setting. If the machine stops because the pressure is too high, the switch automatically resets after the pressure drops below the appropriate setting. Check switch settings. Push the Start touch screen button to start the machine in a thawing period. Check the head pressure during the next freeze period. Refer to Chapter 9, (High/Low Pressure Switch).
Optical oil sensor trips	If the machine stops because the oil level is too low, check the compressor oil-level sensor. A solid red light comes on if tripped. To reset the sensor, add oil to the compressor. The oil level should be ¼ – ¾ in the upper sight glass. Once oil is added to the compressor and the red light is off, the machine is ready to restart.

Machine Not Running, cont.

Possible Causes	Possible Solutions
Cutter motor overload trips	Check and clear the cutter area and ice discharge path of all ice. Check voltage and overload range adjustment against motor rating. Reset the manual motor starter, reset the fault on the touch screen and restart the machine by pushing the Start touch screen button. Check the cutter operation and motor amp draw. If tripping repeats, but there is no ice clogging the cutter area or ice discharge path, check the cutter bearing for wear, the gear reducer for resistance, and the motor for defects or single phasing.
Pump motor overload trips	Check voltage and overload range adjustment against motor rating. Reset the manual motor starter, reset the fault on the touch screen, press the Run Water Pump touch screen button. Check the pump operation and motor amps. If tripping repeats, check for a defective overload, defective motor, or single phasing.
Defective component in control panel	Check for open circuit. Refer to Figure 12 to identify parts. Replace defective part, restart machine, and check power supply and current draw.

Freeze-Up from Extended Freeze Period

Possible Causes	Possible Solutions
Freezer pressure switch setting too low	Adjust freezer pressure switch or replace if defective.
Water tank drain valve or makeup water solenoid open too long	Close, repair, or replace valve as needed.
Thaw gas solenoid valve leaking during the freeze period	Check the manual opening stem to make sure it is in the automatic position (stem screwed out). Check for leakage through the valve by measuring the sound and temperature differences. Close the stop valve at the receiver to confirm leakage. Repair or replace the valve as needed.
Float switch sticks or fails to close	Check to make sure the float switch is opening and closing.
Liquid line solenoid valve (A) is stuck open	Check to make sure the valve is not in the manual open position. Disassemble valve and inspect for debris. Clean valve if required.

Freeze-Up from Ice Failing to Discharge

Possible Causes	Possible Solutions
Insufficient heat for thawing because of low condensing pressure, non-condensable gases (usually air) in system, low refrigerant charge, or thaw gas pressure switch adjusted too low	The head pressure should be maintained at approximately 130 psig (9 bar) for 513A, which relates to 98.7°F (37.0°C) by adjusting the water regulating valve (water-cooled units) or fan cycling switch (air-cooled units). If non-condensable gases are present in the refrigerant, the saturated temperature will not relate to the pressure reading at the receiver. The refrigerant level in the receiver should be near the operating level (marked by the sticker) at the end of a freezing period to provide enough volume for harvesting. (1-in. [2.54 cm] = approx. 10 lb. [4.5 kg] of 513A).
Thawing time too short	Check the thaw timer (T) which should be adjusted to allow all the ice to clear the cutter and ice discharge opening with at least 30 seconds to spare.
Cutter or cutter disc does not turn	Check cutter reducer and drive gear for proper operation and alignment. Check for broken cutter disc or drive pin and replace as necessary.
Ice backs up into cutter or discharge opening, jamming cutter	Ice mushy due to concentration of solids in the water tank. Perform "Cleaning Procedure" and check automatic and adjustable blowdown. If the machine discharges ice into a chute, it should slope at an angle of 30 degrees for cylinder ice, and 45 degrees for crushed ice. Check bin stat or level control to make sure it will stop the machine before ice backs up into the cutter.
Extended freeze period	Check the Freezer Pressure Switch , refer to Chapter 9, (Freezer Pressure Switch on Touch Screen HMI) and Error! Not a valid result for table. Normal Operating Criteria.
Compressor not unloading	Check compressor amps during harvest. A noticeable drop in amperage should occur. Check unloader solenoid coil. If coil is okay, replace unloader head assembly.
Thawing time too short	Check the thaw timer (T), which should be adjusted to allow all the ice to clear the cutter and ice discharge opening with at least 30 seconds to spare.

Poor Ice Quality

Possible Causes	Possible Solutions
Excessive concentration of solids in the water tank, indicated by a build-up of mineral deposit on the sides and bottom of the tank	Clean the water tank. Remove the freezer cover and clean the water distributors. Adjust continuous blowdown.
Insufficient water supply indicated by a low level in the tank	Check water pressure—30 psig [2 bar] is the recommended minimum. Check for a water line restriction, partially closed valve, or defective makeup water float valve. Make sure the water tank drain valve is closed.
Water pump rotation wrong direction	Check rotation by referring to the arrow on the pump housing and reverse two wires at the motor if necessary.
Low refrigerant charge	Check refrigerant level mark on the receiver and on the red portion of the gauge glass guard. Perform a pumpdown if necessary. Keep the gauge glass cocks closed when finished checking the level.
Insufficient blowdown during harvest	Check for proper operation of the siphon vacuum break valve. Check for restrictions or traps in the water tank drain assembly.

Low Ice Capacity

Possible Causes	Possible Solutions
Low refrigerant charge	Check for and repair leaks. Add refrigerant.
Restriction in liquid line	Check for a partially closed valve or an obstruction at the dryer, strainer, solenoid valve, or expansion valve. The liquid line will normally have frost on the downstream side of a restriction, especially as the suction pressure decreases.
Float switch stuck or failed in open position	Make sure the float switch is opening and closing. Make sure the A valve is getting power.
Thaw gas solenoid valve leaking during the freeze period	Check the manual opening stem to make sure it is in the automatic position (stem screwed out). Check for leakage through the valve by measuring sound and temperature differences. Close the stop valve at the receiver to confirm suspicion of leakage. Repair or replace the valve as needed.
Water distributors at top of freezer are clogged	Remove freezer cover and clean the distributors. Refer to <i>Water Distributors</i> in Chapter 7.
Not enough water for ice making	Check water pressure (30 psig [2 bar] minimum is recommended). Check for a water restriction in the supply line or at the makeup water float valve.
Makeup water float valve stuck open, adjusted too high, or water tank drain valve open or leaking	Repair, replace, or adjust float valve as needed. Close, repair, or replace water tank drain valve as needed.

Low Ice Capacity, cont.

Possible Causes	Possible Solutions
Controls for regulating freezing and thawing periods not adjusted properly	For highest capacity, cylinder ice should have a small hole and crushed ice should be about 3/16-in. [4.8-mm] thick. Adjust the freezer pressure switch and thaw timer as needed. Refer to Chapter 9
Excessively high head pressure	Check water regulating valve or fan control adjustment. Clean the condenser if needed. Check refrigerant table for appropriate pressures and temperatures.
Warm makeup water for ice making	Capacity of the machine is proportional to the water temperature during ice making. Warmer water will reduce the ice-making capacity. Refer to HFO10 Capacity Chart.
Drain valve open	Close drain valve.
Low refrigerant charge	Check for and repair leaks. Add refrigerant as needed.
Restriction in liquid line	Check for a partially closed valve, or for an obstruction at the dryer, strainer, solenoid valve, or expansion valve. The liquid line will normally have frost on the downstream side of a restriction, especially as the suction pressure decreases.

High Head Pressure (Water-Cooled Machines)

Possible Causes	Possible Solutions
Misadjusted or defective water regulating valve	Adjust or replace valve. Never adjust the valve stem as far open as it will turn, because it will not close when the head pressure drops.
Insufficient water supply	Check size of water line and pump output at the condenser. Refer to the specification sheet for water requirements. Check cooling tower sump level and makeup water supply.
Cooling tower needs maintenance	Check cooling tower fan belt and tighten or replace as needed. Check spray nozzles and sump screen and clean as needed.
Non-condensable gas (usually air) in system	Check refrigerant tables for appropriate pressures and temperatures. If non-condensable gases are present, perform a total pumpdown. Let stand for at least 6 hours, allowing non-condensable gases to collect in the upper part of the receiver. Evacuate the freezer and attach a recovery unit to the top receiver purge valve. Open the valve and recover the vapor for about five minutes. When the freezer is evacuated, open the thaw gas solenoid valve (D) manually for about 15 seconds, letting the top vapor in the receiver blow into the freezer. Close the solenoid valve and evacuate the freezer again. Evacuate to 500 microns and restart the machine.
Fouled (dirty) condenser	Visually inspect condenser and clean as necessary.
Misadjusted or defective water regulating valve	Adjust or replace the valve. Never adjust the valve stem as far open as it will turn, because it will not close when the head pressure drops.

High Head Pressure (Air-Cooled Machines)

Possible Causes	Possible Solutions
Condenser fan(s) not running; defective motor, fan control switch, fan contactor, or tripped fan motor overload	Replace any defective parts. Check condenser fan disconnect for thrown switch or blown fuse. Replace fuse and reset switch. If the condenser is split, check the normally open solenoid valve to make sure it is open. Also check the fan sequencing thermostats and fan motor contactors to make sure they are functioning properly.
Dirty condenser causing restricted air flow	Visually inspect condenser and clean as necessary.
Non-condensables (usually air) in the system	Follow same procedure as specified for removing non-condensable gases from water-cooled machines and evacuate the air-cooled condenser as well.

Chapter 9 Servicing Operations

Adjustable Blowdown (for Clearer Ice)

A petcock valve, located at the overflow level of the water pump, provides adjustable blowdown from the water tank during the freezing period. The petcock is set at the factory to discharge enough water during the freeze period to produce clear ice. After installation, the petcock should be adjusted to the minimum rate (open as little as possible) required to maintain clear ice, and checked after a few days of ice making to confirm ice is still clear. Figure 61 shows the overall blowdown assembly.

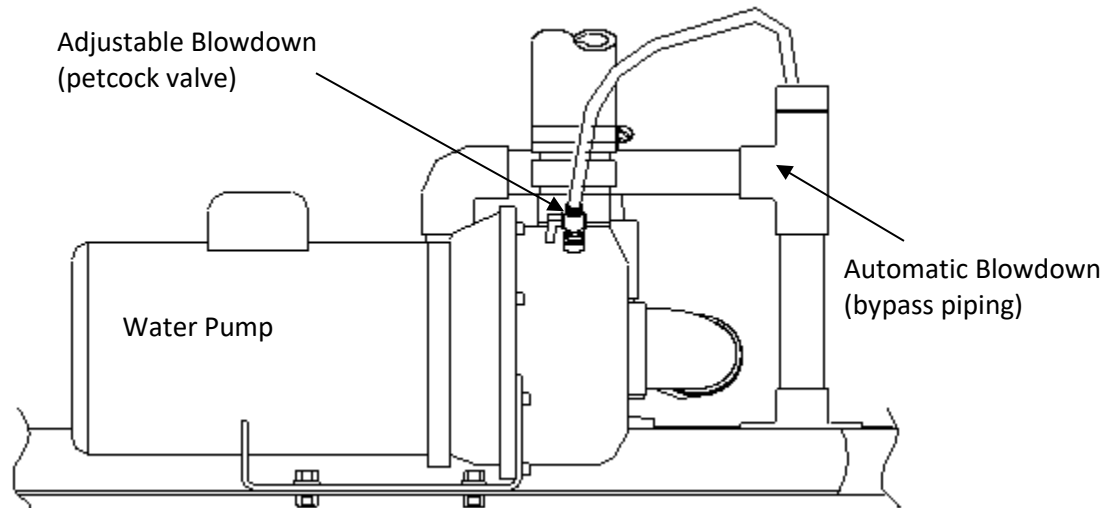

Figure 61: Water Pump/Blowdown Assembly

Automatic Blowdown

The automatic blowdown or harvest period eliminates or reduces the need for frequent flushing or cleaning of the water tank. This blowdown also removes accumulated salts or solids in the water as a result of the freezing action. During the harvest period, water returning from the freezer raises the tank level and causes an overflow of water. The overflow creates a siphon to remove a fixed amount of water (20% of tank capacity) from the tank.

Makeup Water Float Valve

The makeup water float valve maintains the proper pumping water level for ice making. The valve is set to maintain an appropriate level (high enough to prevent pump cavitation and low enough to prevent tank flooding) in the water tank during the freezing period so there will be a quantity of bypass or blowdown only during the thaw mode. The water level during the freeze mode must always be below the bypass piping to prevent excessive waste of cold water; otherwise, loss of ice capacity results.

If cleaning the float valve is required, close the stop valve in the makeup water line to the machine and remove the float valve. After the valve is cleaned and reinstalled, ensure the proper water level is being maintained. After the machine stops, and the water in the tank reaches its normal level, there should be no water flow through the float valve or drain bypass.

Installation of a 40-mesh strainer in the water supply line is recommended. The strainer protects the float valve from dirt or solids in the water and helps reduce the amount of cleaning.

Refrigerant Float Switch

The float switch is installed on a header assembly attached to the freezer shell. Valves provide isolation of the float switch assembly if replacement or servicing is necessary. The float switch closes as the level of refrigerant in the freezer rises, and it opens as the level falls.

The float switch is connected to the liquid line solenoid valve (A) coil (refer to piping schematics and wiring diagrams). This solenoid valve is located in the pipeline directly before the hand expansion valve. When the refrigerant level in the freezer drops, the float switch opens and de-energizes this normally open solenoid valve until the liquid level in the freezer rises enough to close the float switch. The float switch has a fixed 1/2-in. (13-mm) differential.

The float switch is installed at the correct height at the factory to provide the highest ice-making capacity. No adjustment is needed.

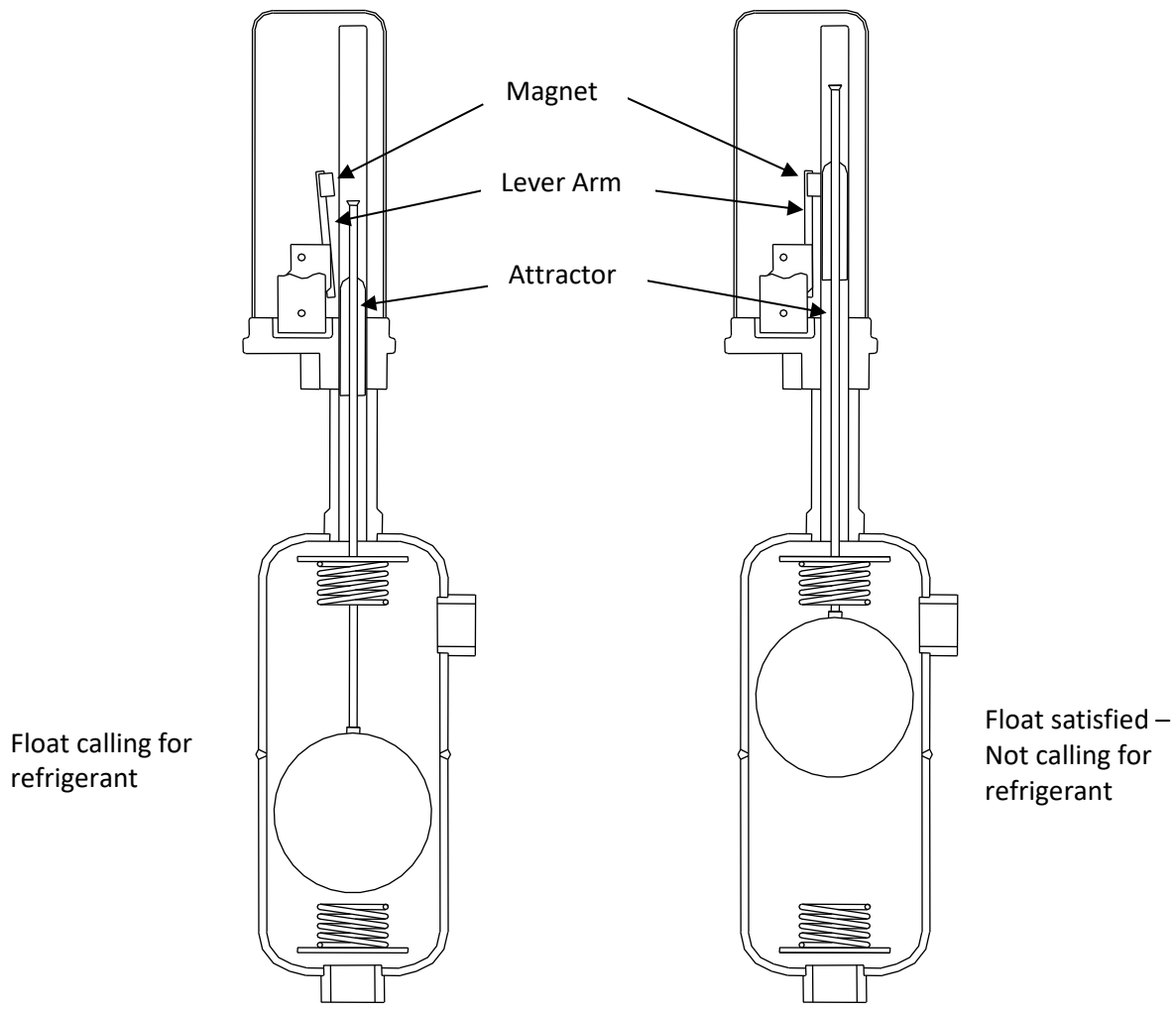

Figure 62: Refrigerant Float Switch

Hand Expansion Valve

The hand expansion valve is located after the liquid line solenoid valve (A). This should be set at a point where the float switch is open for a length of time approximately equal to the time it is closed. The factory setting is about three turns closed from full open.

Freezer Pressure Switch on Touch Screen HMI

The **Freezer Pressure Switch** controls the freezing time period for the production of cylinder or crushed ice. It is adjusted on the **Quick Setup** screen when viewing the **Home** screen on the HMI.

This setpoint is selected at the factory to produce ice of recommended thickness. Refer to the Certificate of Test, which was provided with the machine for a sample set of pressure readings with corresponding time periods and water temperatures. Do not make adjustments until several ice discharging cycles have been completed.

Low Pressure Safety on Touch Screen HMI

The **Low Pressure Safety** will shut the ice machine off if the compressor suction pressure drops below the setpoint. The factory setpoint for the low-pressure safety is 4 psig (0.27 bar). The setpoint where the machine can restart is 20 psig (1.4 bar).

High Pressure Safety on Touch Screen HMI

The **High Pressure Safety** will shut the ice machine off if the compressor discharge pressure reaches the setpoint. The factory setpoint for the maximum safe pressure is 200 psig (13.8 bar). The setpoint where the machine can restart is 145 psig (10 bar).

Head Pressure

For R-513A, the head pressure should be maintained at 145–155 psig (10–10.6 bar) during the freeze cycle. This pressure can be checked at the compressor discharge valve. It is also displayed on the **Home** screen of the HMI.

Fan Cycling Pressure on Touch Screen HMI

For air-cooled machines, the condenser fan cycling is controlled by the PLC and adjusted on the **Quick Setup** screen when viewing the **Home** screen on the HMI. **ON** sets the pressure at which the fans turn on, **OFF** sets the pressure at which the fans turn off. Best performance is achieved with a head pressure range of 145–155 psig (10–10.6 bar). See Figure 24.

Figure 63: Fan Cycling Pressure on Quick Setup Screen

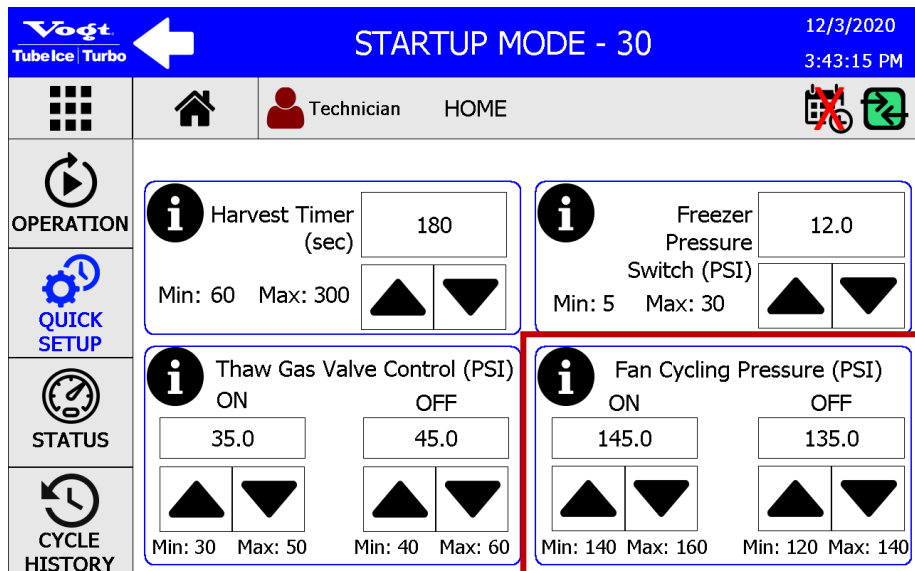

Water-Regulating Valve (Water-Cooled Machines)

A water-regulating valve located in the condenser water inlet controls the water flow through the condenser. This valve should be adjusted to maintain a head pressure of 130–140 psig (9–9.7 bar) for R513A. Increasing the water flow will lower the head pressure, while decreasing the water flow will raise the head pressure. The valve is set at the factory during testing. The valve stem should not be opened all the way because it will not close completely when the head pressure drops below its setting.

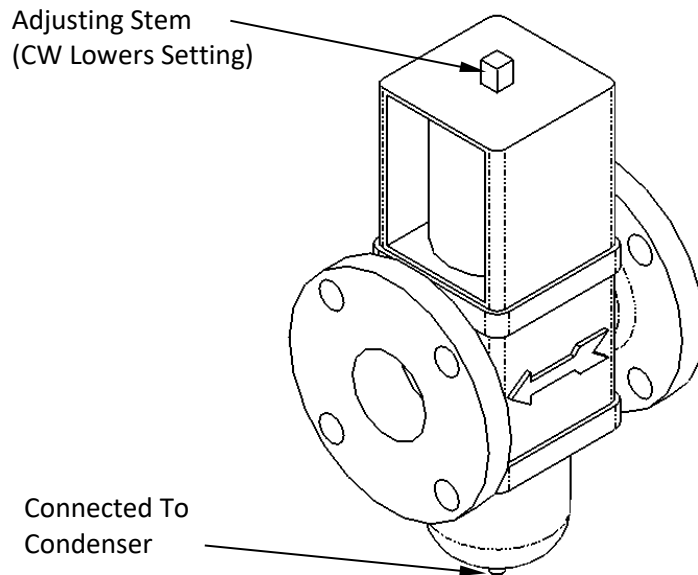

Figure 64: Water Regulating Valve

Cleaning Water-Cooled Condenser

The shell and tube condenser require occasional cleaning to maintain peak performance.

Compressor Motor Protection

The Bitzer Compact screw compressor motor is protected by an electronic motor protection module. If this module fails, it must be replaced. Two different modules are used, depending on how the compressor is powered:

- If the machine does not have a variable frequency drive, motor protection is provided by the Bitzer SE-E1 module. (Vogt part number 12A2110P0505)
- If the machine is equipped with a variable frequency drive, the motor protection is provided by the Bitzer SE-E2 module. (Vogt part number 12A2110P0504)

Table 14: Compressor Parts

Item	Vogt Part No.	Description
Oil Level Control	12A2110P0507	Optical Oil Level Control, 230V Control Power
Unloader Coil	12A2110P0508	Coil, Unloader, 230V, 8W
Crankcase Heater - 230v	12A7509E25	Crankcase Heater, 230V, 200W, for CSH65/75
Electronic Motor Protection Mod-STD	12A2110P0505	INT SE-E1 Module for Compact Screw with no VFD, 115/230V
Screw Compressor	12A2110Z052	Compressor, Screw, 35HP

Compressor Motor Protection—Field Diagnosis

The protective devices SE-E1 or SE-E2 monitor motor and discharge gas temperatures, rotating direction, and check for phase loss.

- **Temperature monitoring.** Locks out immediately if pre-set temperatures for the motor, discharge gas, or the oil are exceeded. Acceptable temperature range is -22° to 140°F (-30 to 60°C).
- **Compressor Rotation.** Checks the rotation direction during the first 5 seconds of compressor operation. If the compressor starts with the wrong rotation direction, the module locks out immediately.
- **Phase Loss.** Checks for phase loss in the first 5 seconds of compressor operation and opens relay contact immediately if phase loss occurs. The contact closes after 6 minutes. If three-phase losses occur within 18 minutes, or 10 within 24 hours, the module locks out.
- **Reset.** To reset after a lock out, power must be removed from the module for 5 seconds.

Compressor Motor Burnout

Compressor motor burnout can have several causes, including:

- **Low Line Voltage.** A compressor motor is designed to operate within the range of $\pm 10\%$ of its nameplate voltage. Low voltage requires the motor windings to carry more current at the same compressor load. When this current becomes too high or is applied for an extended period, the motor windings overheat, resulting in a failure.
- **Loss of Refrigerant.** The semi-hermetic compressor motor is maintained at proper operating temperature by passing cool suction gas over the motor windings. A loss of refrigerant can cause the winding to overheat, resulting in a failure or burnout.
- **High Head Pressure.** The system is designed to operate at 130 psig (9 bar). Excessive head pressure increases the refrigeration load on the compressor. This increase can cause the windings to overheat, resulting in a failure or burnout.
- **Moisture.** Moisture in contact with refrigerant oil and the presence of heat will form hydrochloric or hydrofluoric acid. The acid will destroy the insulation on the motor windings, causing a short circuit, which can increase motor temperatures in excess of 3,000°F (1,649°C). This extreme temperature will also create a sludge or black residue in the system.
- **Mechanical Failure.** Mechanical failure has been determined to be a major cause of motor burnout. Bearing wear or wipe-out may allow the rotor to drag, overheating the windings and causing a burnout.

Whenever a compressor fails because of a motor burnout, it is important to thoroughly clean the system before replacing the damaged compressor, or a new compressor may also become damaged.

Oil Level Safety

The Bitzer CSH compressor used on the HFO10 uses an optical oil-level control. This consists of a prism and an opto-electronic unit (OLC-D1) (refer to wiring diagram). The prism, a glass cone, is mounted directly into the compressor body and the opto-electronic unit is screwed into the prism. If the oil level drops below the optical sensor, the red LED light comes on, indicating a low oil level. If the sensor does not detect an oil level for 5 seconds, the oil level control switch opens, and the machine shuts off.



Figure 65: Oil Level Switch

Note: If the LED blinks, there is a problem with the oil sensor (low voltage supply or sensor is installed incorrectly).

Compressor Crankcase Heater (200 Watt)

When electrical power is supplied to terminals L1, L2, and L3 of the control panel, the crankcase heater is energized when the machine is not operating. It is de-energized when the compressor contactor is energized.

In case of a power interruption, or crankcase heater failure, the crankcase heater should be powered on for a minimum of 2 hours before restarting machine manually. See Figure 26 and Figure 27 for location on the machine.

Oil Separator

To handle all oil management needs, an integrated oil separator is installed inside the Bitzer CSH compressor. The integrated oil separator and built-in suction gas-cooled motor simplify the system integration and enable a compact and cost-effective system design.

Control Circuit Protection

Chapter 2 The electrical control circuit of the machine is protected by a 2-pole, 3A circuit breaker. If the breaker opens, the machine stops immediately. Before opening the panel to reset the breaker, open the disconnect switch to the machine first.

Chapter 3 When power is restored to the machine, follow the prompts on the HMI to restart the machine.

Thawing Timer

The **Harvest Timer** governs the length of the ice thawing period.

The **Harvest Timer** is set from the factory for a time that is at least 30 seconds longer than the time required to harvest the entire discharge of ice. Should it become necessary to change the duration of a thawing period, the **Harvest Timer** can be adjusted through the **Quick Setup** submenu from the **Home Screen** of the HMI. After adjustment, verify the new setting is at least 30 seconds longer than the time required for the last piece of ice to be discharged from the machine.

The screenshot shows the HMI interface in 'STARTUP MODE - 30'. The top bar includes the Voegt logo, a back arrow, the date '12/3/2020', and the time '3:43:15 PM'. Below the bar are navigation icons for a grid, home, technician, and home, along with status icons for a warning and a refresh. The main area is divided into four panels:

- OPERATION**: Harvest Timer (sec) set to 180. Min: 60, Max: 300. (This panel is highlighted with a red box in the image.)
- QUICK SETUP**: Freezer Pressure Switch (PSI) set to 12.0. Min: 5, Max: 30.
- STATUS**: Thaw Gas Valve Control (PSI) with ON (35.0) and OFF (45.0) settings. Min: 30, Max: 50.
- CYCLE HISTORY**: Fan Cycling Pressure (PSI) with ON (145.0) and OFF (135.0) settings. Min: 140, Max: 160.

Pumpdown

The pumpdown function transfers all the liquid refrigerant from the freezer (evaporator) into the receiver. This function is only performed when the freezer is clear of ice and before or during the following operations:

- Checking the total refrigerant charge
- Performing service or repair work on the machine
- Winterizing the machine
- Preparing the machine for disconnecting and moving
- Before cleaning

To perform a pumpdown, follow these steps:

1. Close the liquid stop valve (king valve) at the receiver during a freeze cycle.
2. Allow the machine to enter into a thawing cycle and empty the freezer of all ice.
3. While in the harvest, open the water tank drain valve partially to allow a continuous flow of warm makeup water into the tank while still maintaining the appropriate water level. An auxiliary supply of warm water (not to exceed 100°F [38°C]) may be used if available.
4. On the touch screen HMI, access the **Troubleshooting** menu from the **Menu** screen.

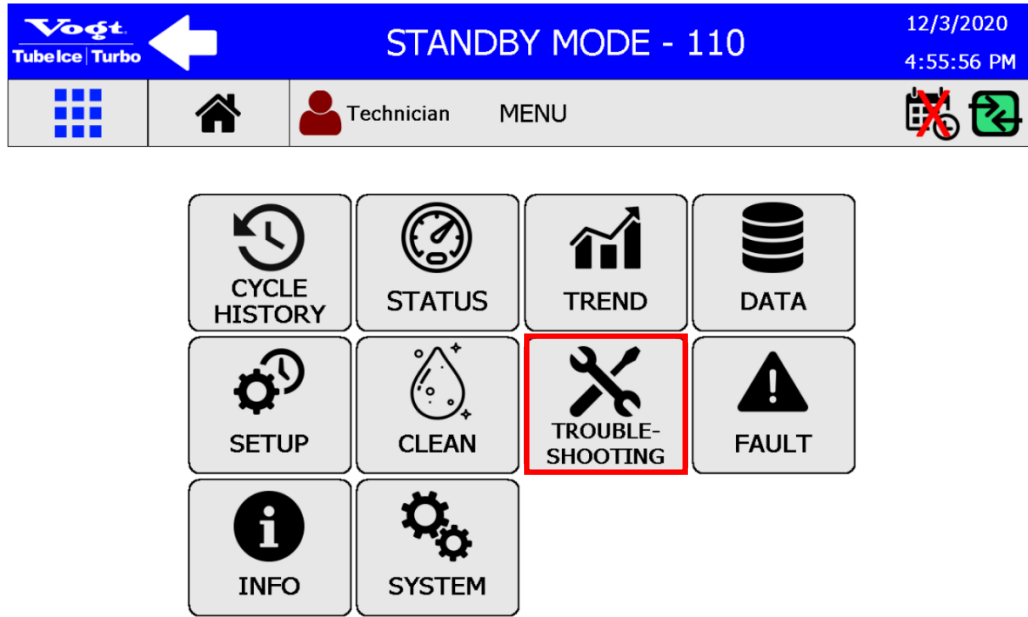

Figure 66: Troubleshooting Icon

1. When the machine begins to enter the next freeze cycle, press the **Pumpdown Mode** touch screen button in the **Troubleshooting** menu.

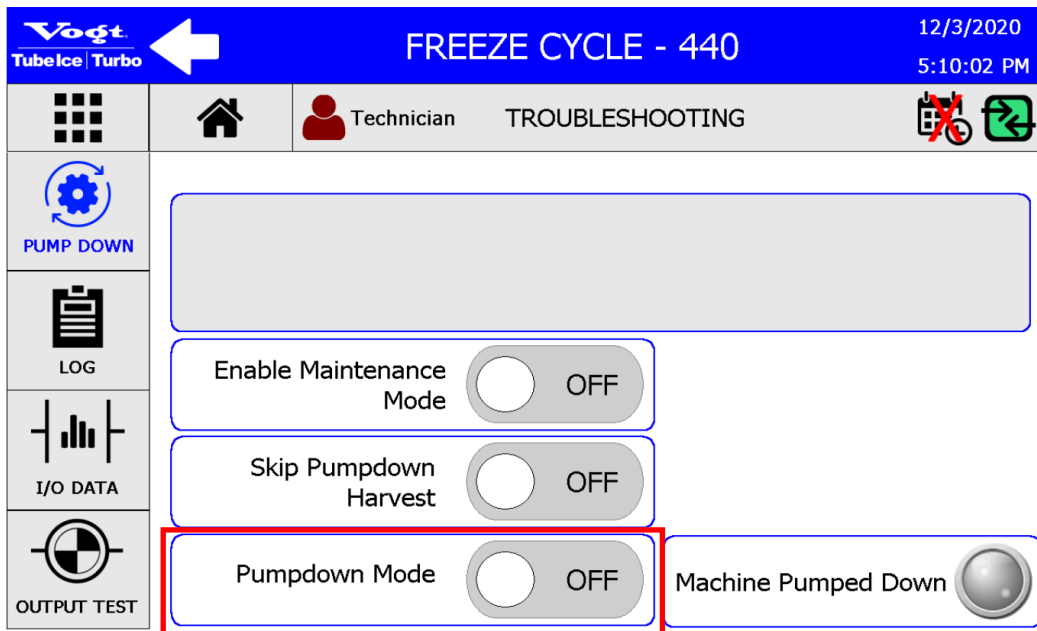

Figure 67: Pumpdown Mode Touch Screen Button

2. Allow the machine to operate until the **Freezer Pressure Switch** reaches the normal setpoint and enters a 60 second **Pumpdown Harvest**.
3. After completion of the **Pumpdown Harvest**, the machine will operate until it reaches 3 psi. The machine will shut off.
4. Close the thawing gas stop valve, the receiver liquid return stop valve, the compressor suction valve, and the compressor discharge valve.

Removing Refrigerant

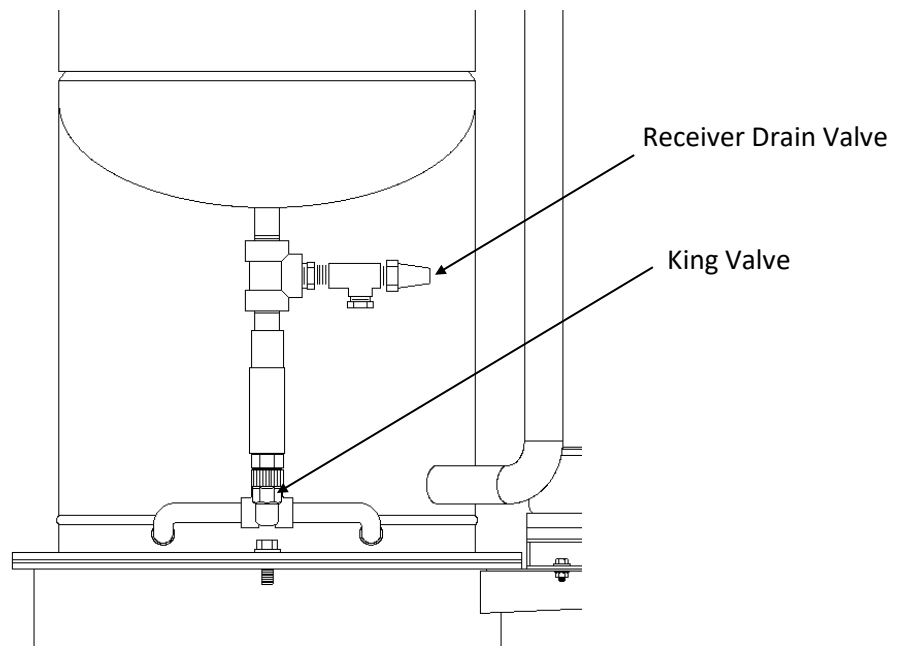

Figure 68: Receiver Drain Valve



Warning: Approved refrigerant recovery equipment, hoses, gauges, and refrigerant containers must be used in compliance with all local and federal regulations. Only qualified personnel should perform refrigerant servicing and recovery processes. Follow these instructions carefully. Severe personal injury can result from improper discharge of refrigerant. It is not recommended to transfer refrigerant from a refrigeration system directly into a cylinder unless this cylinder is an approved, clean cylinder (free of any contaminants or foreign materials). The cylinder must be weighed continuously to assure contents do not exceed the net weight specified by the cylinder manufacturer or any applicable code requirements.

Note: Observe all local codes when handling and discharging refrigerant.

Refrigerant Leaks

It is recommended to complete a leak test after the unit has been in operation for approximately one week. Any noticeable change in operating conditions, other than shown on the Certificate of Test, may indicate a loss of refrigerant due to a leak. Always completely evacuate and recover the refrigerant from the vessel or tubing before repairs are attempted.

Non-Condensable Gases

Air and other non-condensable gases in a refrigeration system are not desirable and can cause unsatisfactory machine performance. Non-condensable gas effects are:

- Higher condensing pressure than what should match the condensed liquid temperature according to a pressure-temperature chart
- Greater electrical power consumption
- Reduced refrigeration capacity
- Longer than normal compressor running time
- Slow ice release

- Long thaw cycle

Air collects mostly in high-pressure condensers, receivers, and other high-pressure components. It is most commonly found in the coolest, lowest-velocity area of these components.

Evaporative condensers usually have purge points at the top of the outlet header of each circuit. Receivers usually have a purge point at the top, away from the inlet, where it is coolest, and the gas velocity is the lowest.

Excessive condensing pressure in water-cooled condensers may also be due to:

- Accumulation of scale in the cooling coil
- Insufficient cooling water
- Excessive water temperature

Solenoid Valves

All solenoid valves are pilot operated with floating-type diaphragms. For satisfactory operation, make sure the manual opening stem is in the automatic position (stem is fully backseated or out). Correct direction of stem rotation is shown on the stem seal nut with an arrow, as shown in Figure 35.

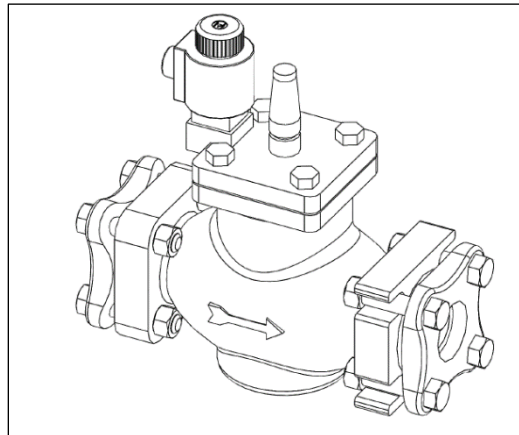

Figure 69: Thaw Gas Solenoid Valve (D Valve)

Table 11 shows replacement part numbers for the thaw gas solenoid valve:

Table 15: Thaw Gas Solenoid Valve (D) Replacement Pats

Part Description	Vogt Part Number
	Hansen (HS4W)
Complete Valve Without Coil	12A4200A1204
Coil	126229 (208/230V, 50/60 Hz)
Rebuild Kit	New

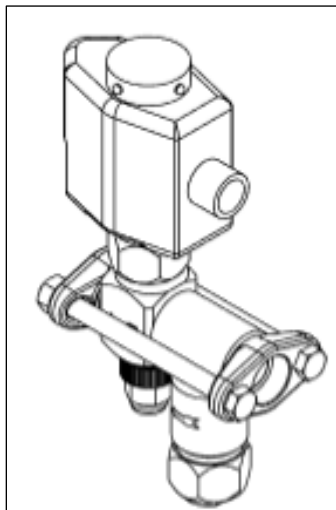

Figure 70: Hansen Parker RS Liquid Line Solenoid Valve (A)

Table 12 shows replacement part numbers for the liquid line solenoid valve (A):

Table 16: Liquid Line Solenoid Valve (A) Replacement Parts

Part Description	Vogt Part Number RS (S8F)
Complete Valve w/strainer & 240V Coil	12A4200A0604RS
Coil	126246 (240V, 60 Hz), 126247 (230V, 50 Hz)
Rebuild Kit (Cartridge Assy, Gasket Kit & Solenoid Tube/Plunger Kit)	N/A

Capacity Control Valves

The Bitzer CSH semi-hermetic compact screw compressor features capacity control solenoids that adjust the slide valve to use only a portion of the screw's length. This reduces the amount of load at which the compressor operates, which allows the ice machine to release all the ice in a timely manner during the harvest period. The solenoids direct the flow of the oil being circulated within the compressor body to control the direction of the slide valve, and the amount that it moves. Only capacity control valves (Y3=25% and Y4=100%) are used for this compressor.

- **100% Loaded Operation (Freeze Period)**—During the freeze period, capacity valve Y4 (100% loaded) is energized, which allows the compressor to operate fully loaded.
- **25% Loaded Operation (Harvest Period Only)**—During the harvest period, capacity valve Y4 de-energizes, and Y3 (25% loaded) is energized to allow the slide valve to unload the compressor.

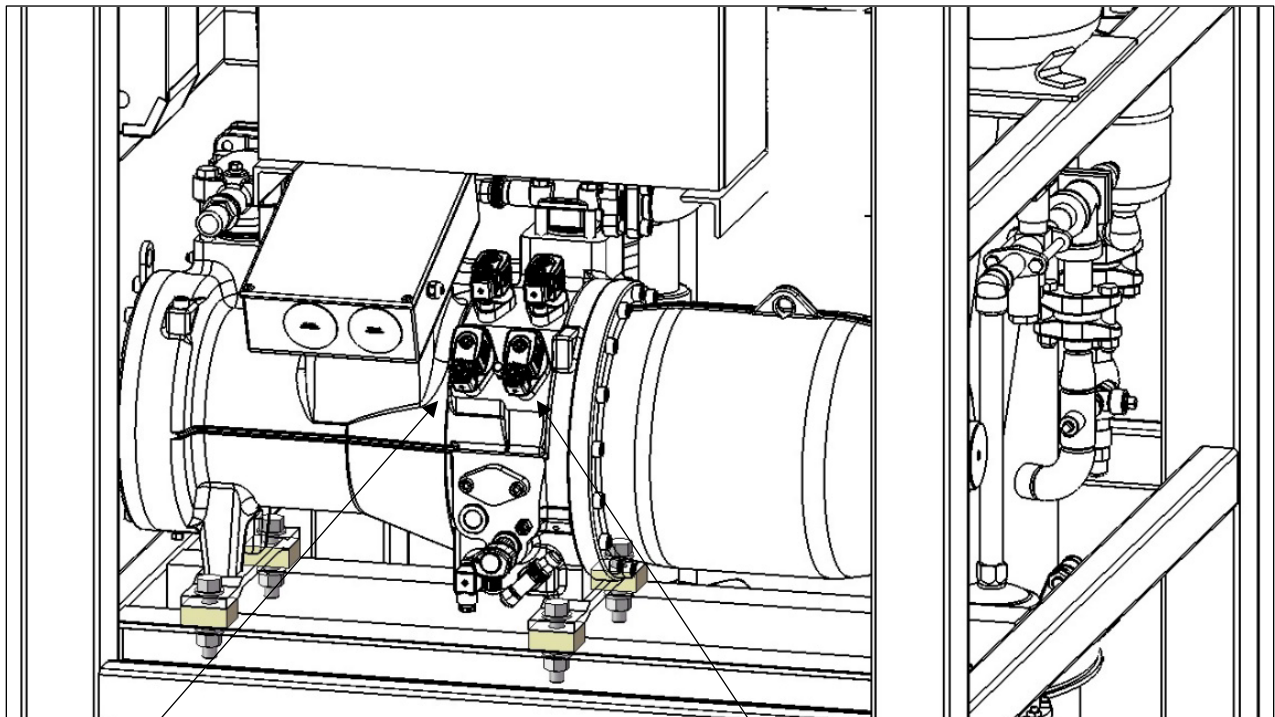

Capacity Valve – Y3 (load 25%)

Capacity Valve – Y4 (load 100%)

Figure 71: Bitzer CSH Semi-Hermetic Compact Screw Compressor Showing Capacity Valves

Circulating Water Pump Motor

The motor bearings are pre-lubricated and sealed. They require no further lubrication. The pump should operate with the water level above the impeller housing. The pump also has a mechanical seal that requires no lubrication and is self-adjusting. However, the pump should not be operated unless it is circulating water. The pump manufacturer recommends that a mechanical seal be kept as a spare. When ordering a seal, specify pump size, type, serial number, and manufacturer’s name as indicated on the nameplate.

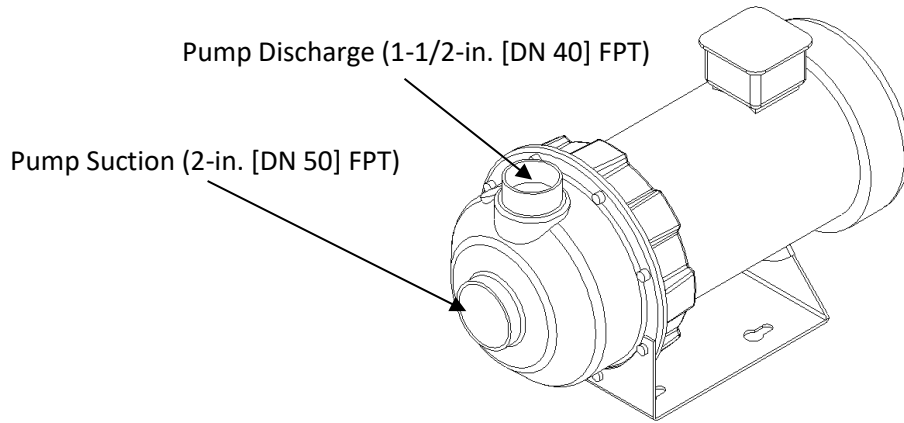

Figure 72: Circulating Water Pump

Table 13 shows replacement part numbers for the water pump and seal kit:

Table 17: Circulating Water Pump Parts

Part Description	Vogt Part Number
Water Pump Seal Kit	12A4080S12
Water Pump, 60 Hz	12A4020G01
Water Pump, 50 Hz	12A4020G08

Cutter Gear Reducer

The oil level for the gear reducer should be level with the plugged opening in the side of the gear housing. If not, this is evidence of a leak. Use food-grade oil and change oil once a year. The motor bearings are pre-lubricated and require no further lubrication.

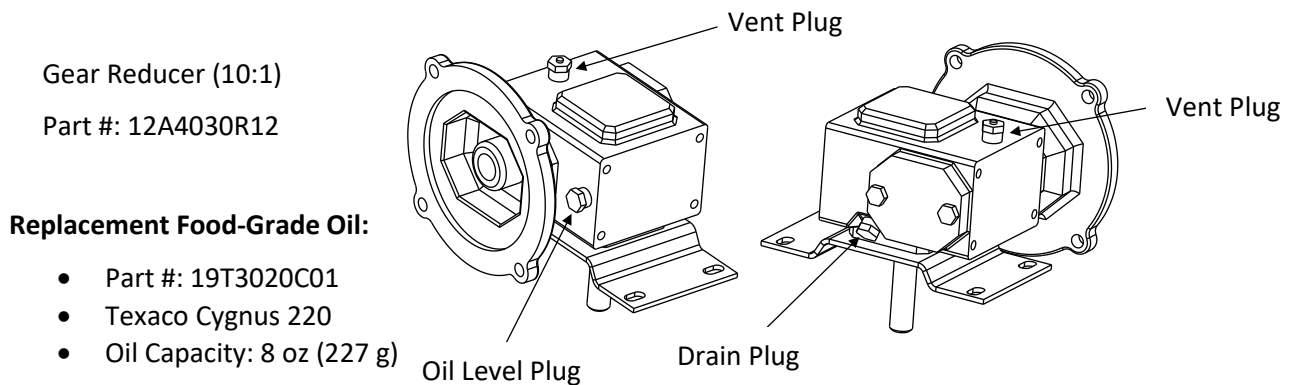

Figure 73: Gear Reducer

Table 14 shows replacement part numbers for the gear reducer and lubricating oil:

Table 18: Gear Reducer Service Parts

Part Description	Vogt Part Number
Gear Reducer, 10:1, Cylinder Ice	12A4030R12
Food-Grade Lubricating Oil (8 Oz [227 g])	19T3020C01

Cutter Motor Replacement

The cutter motor bearings are pre-lubricated and sealed, requiring no further lubrication or maintenance. If the motor requires replacement, follow the steps below:

1. Turn the power off and lock out the disconnect.
2. Check terminals with voltmeter to confirm the power is off.
3. Remove motor terminal cover and disconnect wires. Mark wires for ease of replacement.
4. Remove four cap screws around the motor flange and separate the motor from the reducer. Watch for shaft key that must be reinstalled later. Replacement motor does not come with a new key.
5. Check the motor electrically for shorts to confirm that it is defective.
6. Apply anti-seize lubricant to the shaft of the replacement motor.
7. Position the shaft key in the motor keyway, align it with the reducer keyway, and install the motor. Make sure that the key stays in position as the shaft is inserted.
8. Install the four cap screws to hold the motor in place on the reducer.
9. Connect the wires and install the terminal cover.
10. Check motor rotation to verify that the cutter turns counterclockwise. Reverse two wires at the motor if necessary, to change rotation direction.

Cutter Gear Reducer Removal and Replacement

To remove the gear reducer, follow the steps below (refer to Figure 41):

1. Turn the power off and lock out the disconnect.
2. Remove the motor from the gear reducer.
3. Slightly loosen the 4 bolts and nuts holding the gear reducer in place.
4. Remove the four bolts holding the mounting plate to the water tank gear enclosure and remove the gear reducer and mounting plate from the tank.
5. Measure the distance between the top of the drive gear and the mounting plate for future reference.
6. Remove the three cap screws from the gear and hub and install 2-1/4-in. [57 mm] -20 x 2-in. [51 mm] long cap screws in the threaded holes of the drive gear. These two screws can be used as jacking bolts to remove the gear from the taper split hub.
7. The split hub is removed by placing a screwdriver in the split and sliding the hub off the shaft.
8. The new gear reducer is installed by reversing the removal procedure.
9. Check that the gear and hub are properly positioned on the shaft. The driver and cutter ring gears must mesh completely along the gear thickness as installed in the machine.
10. Adjust the final gear mesh so that only a slight amount of play exists between the drive gear and the ring gear.
11. Check that all bolts are tightened securely and that there is no excessive gear noise when the cutter motor is running.

Water Tank Removal

To remove the water tank from the machine, follow the steps below:

1. Turn off and lock out power to the machine.
2. Turn off water supply and disconnect lines from the tank.
3. Drain the tank and disconnect pump suction tube and drain line tubing and water lines.
4. Disconnect the ice discharge chute if installed.
5. Loosen water tank clamp that couples the plastic tank to the cutter housing assembly.
6. The tank can then be removed from the side of the machine where the float valve is installed.

Cutter and Bearing Removal and Reinstallation

Follow the steps below. Refer to Figure 40 and Figure 41.

1. Turn off the power and lock out the disconnect.
2. Remove the cutter motor from the reducer.
3. Remove the water tank from the machine.
4. With a 1/4-in. (8 mm) or smaller punch, reach into the ice discharge opening and drive the spiral pin out of the disc assembly. Push or drive the disc off the shaft.
5. Lift the cutter assembly out of the bearing surface of the cutter. The surface should be smooth and free of nicks or burrs.
6. Inspect the bearing for wear. No side movement between the shaft and bearing should exist. The bearing thrust flange should be no thinner than 3/16 in. (5 mm). Replace if worn.
7. Before removing the bearing, reference mark the location of the cutter support arms on the side of the tank. The cutter support orientation is specific to the tank.
8. Loosen and remove the three cap screws from the cutter support ends and lift the support out of the water tank.
9. Drive out the 3/16-in. (5-mm) pin located in the side of the cutter support hub that holds the bearing in place.
10. Push the bearing out of the cutter support hub.

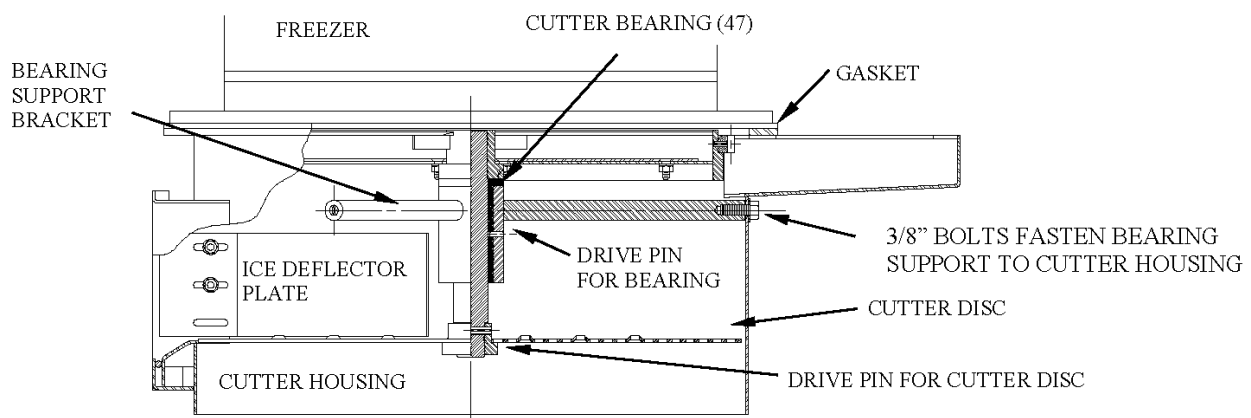

Figure 74: Cutter Assembly

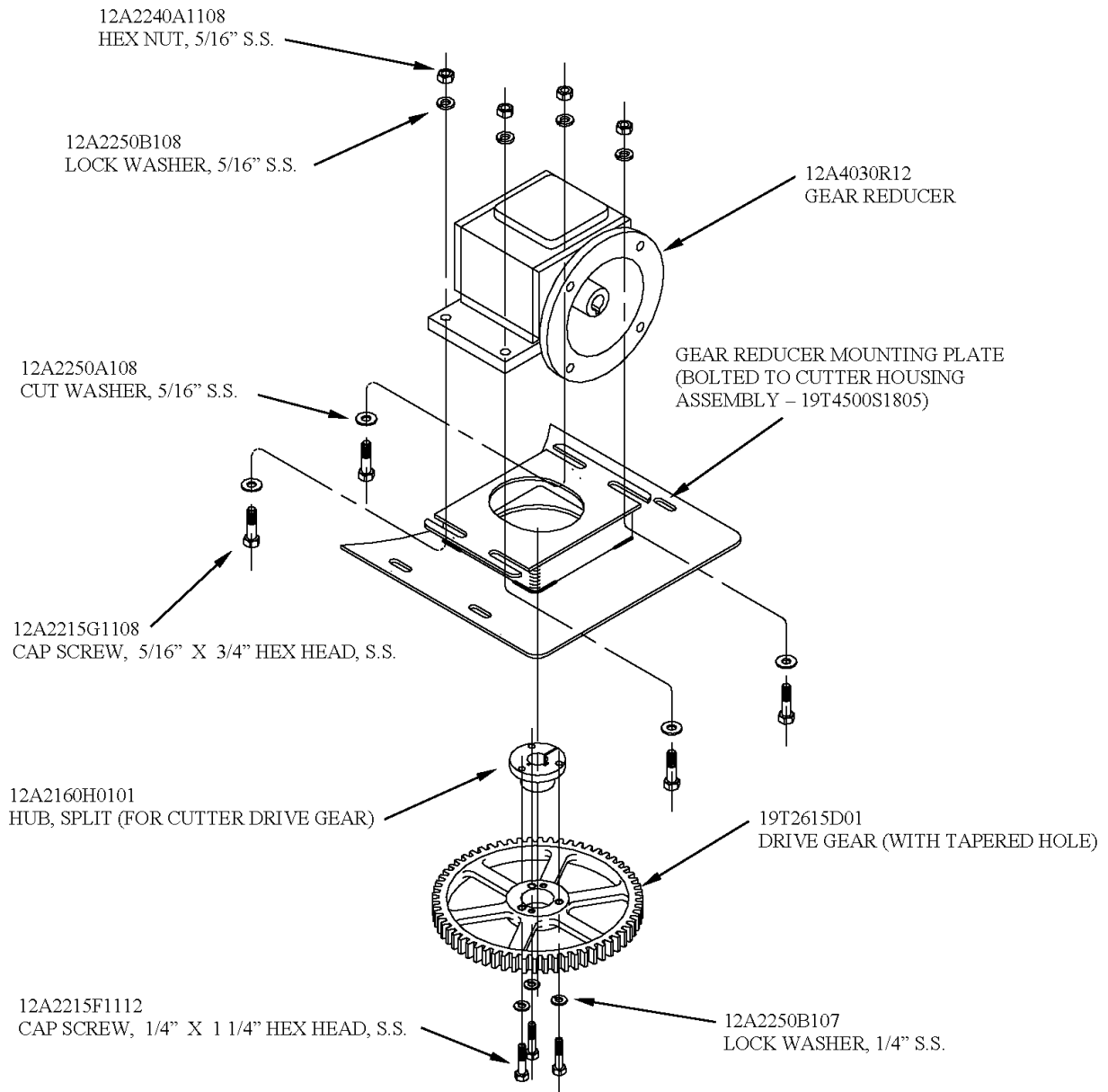

Figure 75: Cutter Drive Parts

To re-install the breaker cutter and bearing, follow steps 1-8 below:

1. Push the new bearing into the cutter support hub.
2. Using the pin hole in the side of the cutter support hub as a guide, drill a 3/16-in. (5-mm) hole through the wall of the bearing.
3. Drive in the 3/16-in. (5-mm) pin through the drilled hole until it is flush with the outside wall of the cutter support hub. Check that the pin does not extend into the surface inner diameter (ID) of the bearing.
4. Slide the new bearing and cutter support onto the cutter shaft and check that it spins freely. If the fit is tight, carefully ream the inner surface (ID) of the bearing until it turns freely.
5. Install the bearing support in the water tank, using the reference marks you made as a guide.

6. Slide the cutter and shaft into the bearing and check the cutter alignment. Lay a straight edge across the top flange of the tank and verify that the clearance between the rim of the cutter and the top of the tank flange is between 0 and 1/16 in. (2 mm). Loosen the bearing support cap screws and move the support arms up or down to achieve proper alignment.
7. Tighten the support screws securely and reinstall the cutter and cutter disc.
8. Install the tank and other parts, reversing the procedure of removal.

Crushed Ice Production

HFO10 Tube-Ice® machines with tube sizes of 1-1/4 in. (32 mm) or 1-1/2 in. (38 mm) can be converted to produce crushed ice with no loss in capacity. Some changes are required to convert the machine for crushed ice production, as noted below:

The following parts must be added to the machine:

Table 19: Cutter Parts (Crushed Ice Option)

Part Description	Vogt Part Number
Crushed Ice Cutter Assembly	126413B
3/4 HP Cutter Motor (60 Hz, 208-230V/460V, 3.2A/1.6A)	12A2900M0601
3/4 HP Cutter Motor (50 Hz, 190V/380V, 4.2A/2.1A)	12A2900M0603
5:1 Cutter Gear Reducer	12A4030R14
Cutter Motor Starter <ul style="list-style-type: none"> • 60 Hz, 208-230V, 2.5-4.0A • 60 Hz, 460v, 1.6-2.5A • 50 Hz, 200V, 4.0-6.3A • 50 Hz, 400V, 1.6-2.5A 	<ul style="list-style-type: none"> • 12A7530E55UL • 12A7530E54UL • 12A7530E56UL • 12A7530E54UL

Change:

1. Raise the freezer pressure switch setting to make ice 3/16-in. (5-mm) thick (average).
2. Reverse cutter direction.
3. Reverse deflector.

Two people should normally accomplish this conversion process in 6-8 hours (or less). There must be ample room around the machine for the water tank removal. It is recommended that you have good quality water when attempting to produce crushed ice. If the ice is opaque and cloudy, it is subject to clog the cutter mechanism, restrict ice discharge, and bind the cutter. Also, you should not attempt to produce crushed ice when the makeup water temperature is below 50°F (10°C). Colder water can cause a build-up of ice fines in the tank and eventually result in “short-cycling.”

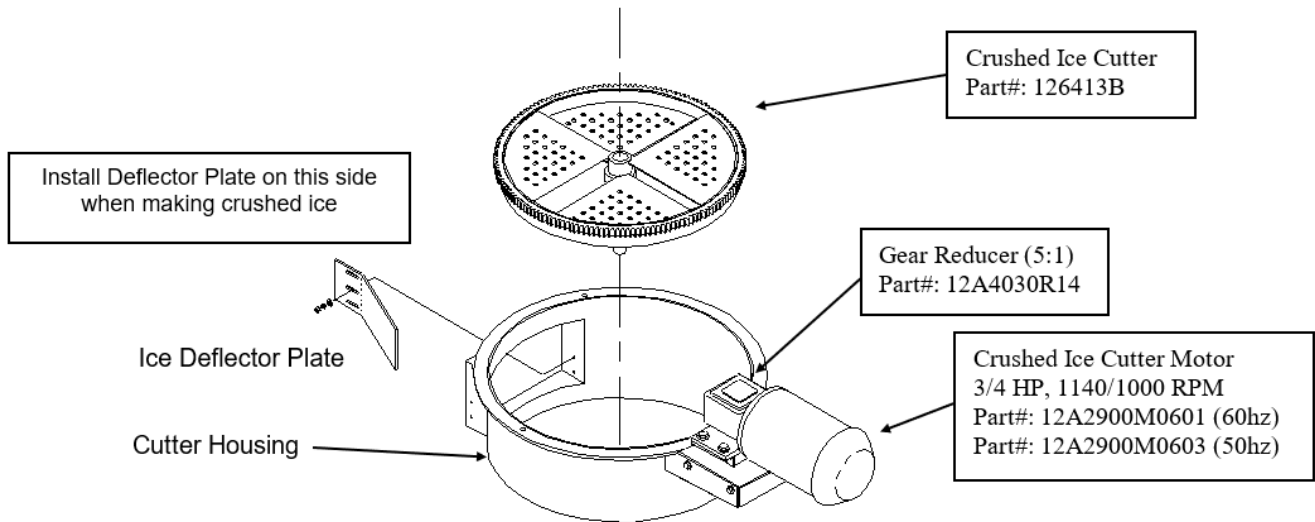

Figure 76: Cutter Parts (crushed ice option)

Figure 43 shows the various cutter parts for cylinder ice to help determine which parts require replacement.

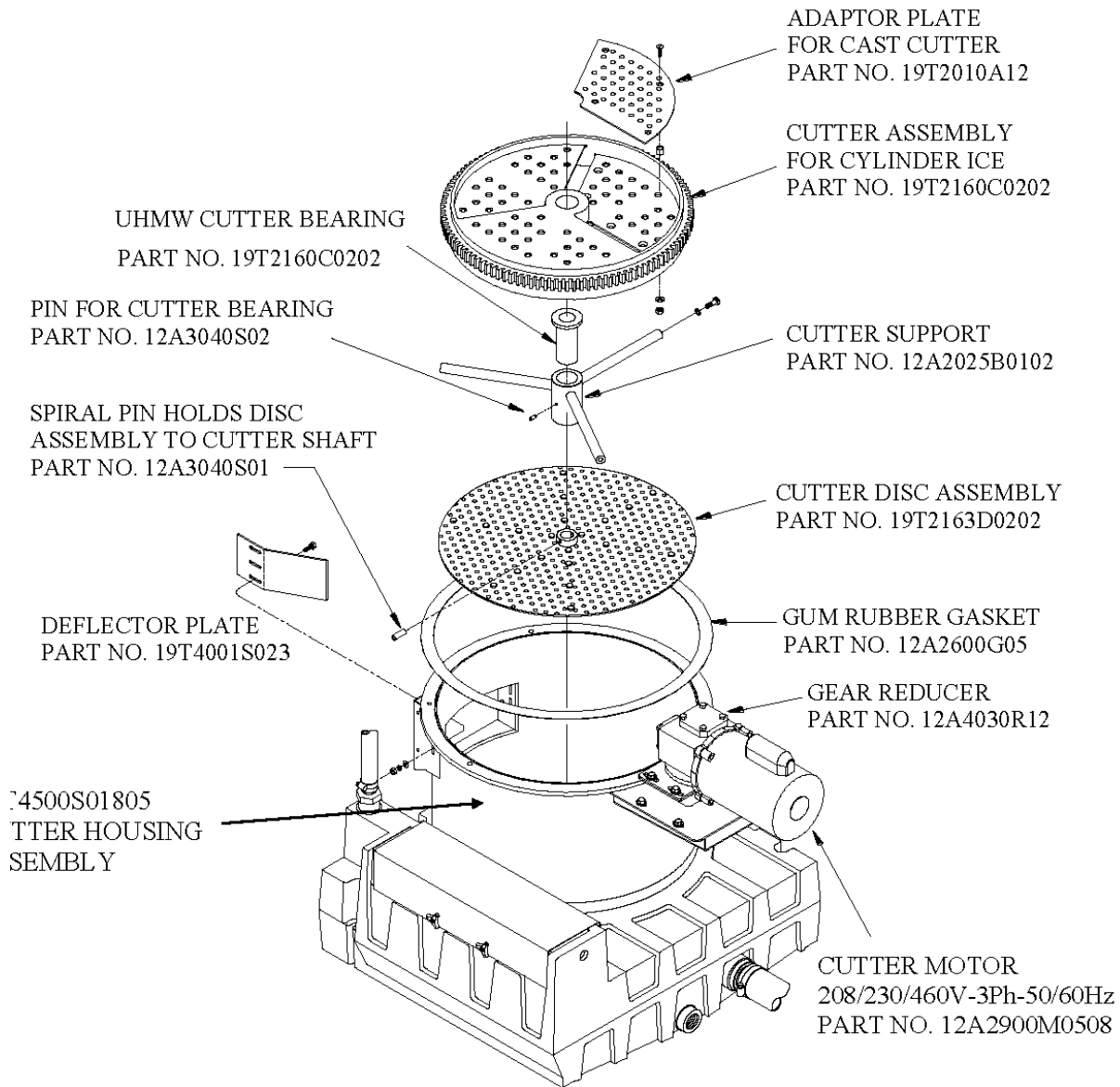

Figure 77: Cutter Parts (Cylinder Ice)

The following changes must be made to the machine:

- Raise the freezer pressure switch setting to make ice with an average thickness of 3/16 in. (5 mm)
- Reverse the rotational direction of the cutter motor.
- Reverse the installation orientation of the ice deflector plate.

Appendix A Optional Accessories

The following sections describe the optional accessories available.

Power Monitor, Wagner Model DTP-3

All Vogt Tube-Ice® machine models are available from the factory with a three-phase line voltage power monitor, incorporating an LCD display, called the DTP-3, as shown in Figure 44. The units are also available for aftermarket or retrofit installation. These units monitor line voltage inputs from 190 to 610 volts and provide protection against line voltage variances, which can damage or destroy the compressor motor.

Features include:

- Non-volatile system memory to retain settings when power is lost.

If the machine is ordered with this option, the power monitor can be factory set to customer specifications. The Vogt part number for a power monitor retrofit kit is 12A7700K01.

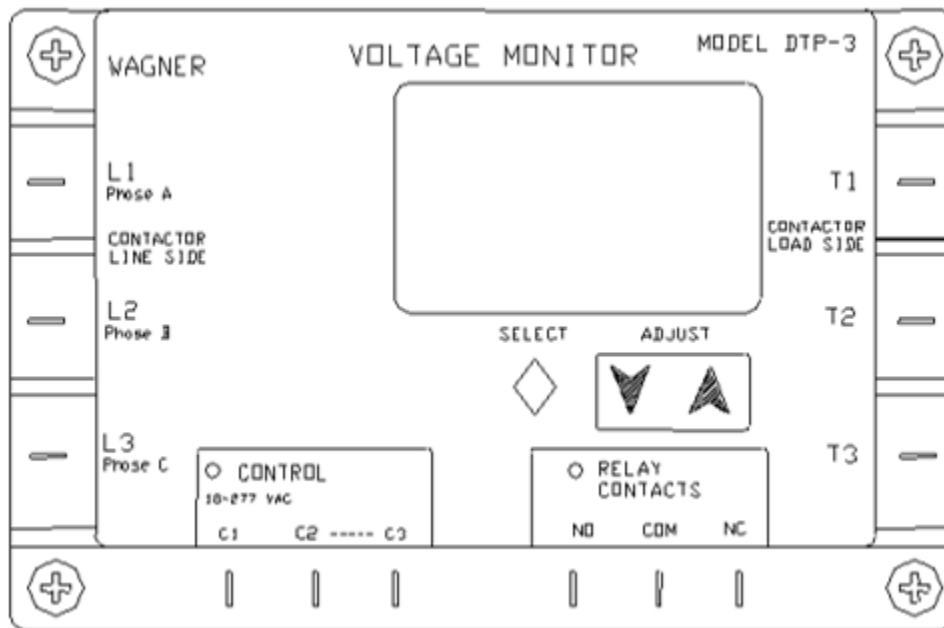

Figure 78: Power Monitor (Voltage Monitor)

The Display

The display normally shows phase A to B, phase B to C, and C to A line voltages. If the unit is on a timer, that timer will be displayed. The timer display may be switched off by pressing **SELECT**. The LCD will then display the normal A-B, B-C, C-A line voltage pairs.

Pressing **SELECT** once shows the contactor load side voltages (if the load side option is connected). The display automatically returns to the display of line side voltage after a few seconds.

Press **SELECT** to step through the parameters, as shown in Table 16. The selected parameter will flash. Use the up and down arrow keys to select the desired operating value.

Table 20: Power Monitor Parameters

Parameter (Description, units)	Min.	Max.	Default	Recommended Settings
Line Side Voltage (Nominal Voltage, volts)	90	650	208	Supply voltage
Over Voltage (tolerance, %)	6	18	12	10
Under Voltage (tolerance, %)	6	18	12	10
Phase Unbalance (%)	2	25	6	5
Lockout Time (Delay on Break, seconds)	0.1	25	0.5	120
Delay Time (Delay on Make, seconds)	0	30	0	0
Response Time (Delay on Fault, seconds)	0.1	20	2	2
Control Mode (none)	Off / Auto / On		Auto	On
Contactors Test (Volt Diff)	OFF	5	OFF	OFF

Adjustment of Parameters in Order of Display

The following describes how to adjust the power monitor parameters in order of display if adjustment is needed.

- **Line Voltage**—This gives an active display of the line voltage to the machine. By default, this is the normal display.
- **Load Side Voltage**—If connected, this provides an active display of the load side voltage in the machine.
- **Voltage Setpoint** (VAC Flashes)—Press the UP and DOWN arrows. This may be set to the normal operating voltage of the device being protected. Adjustment increments are 1 volt.
- **Under/Over Voltage Tolerance** (UNDERVOLTAGE/OVERVOLTAGE Flashes)—Press the UP and DOWN arrows. The tolerance is displayed in percentages.
- **Imbalance Voltage Tolerance** (% IMBALANCE Flashes)—This value may be adjusted by pressing the UP and DOWN arrows.
- **Lockout Time** (SECONDS Flashes)—This value may be adjusted by pressing the UP and DOWN arrows. This is the delay-on-break timer value.
- **Delay Time** (RESP. SECONDS Flashes)—This display shows time in seconds and tenths of seconds. This value may be adjusted by pressing the UP and DOWN arrows. This is the time that a fault is allowed before shutdown occurs.
- **Control Mode** (ON OFF AUTO Flashes)—This value may be adjusted to OFF (load will not turn on), ON (load will turn on whenever no faults exist and timers are finished), and AUTO (load will turn on when a control input is active).
- **Contactors Fault Monitor Mode** (CONTACTOR FAULT Flashes)—This option allows for monitoring of the contactor and provides lock-out if the line voltage and load side voltage vary by more than five (5) volts. Pressing the UP or DOWN arrow will toggle between OFF (default) and ON. The load side of the contactor must be connected to the load terminals of the power monitor to use this option.
- **Display of Fault Memories** (MEM Flashes)—Pressing UP or DOWN arrow displays the last fault conditions that shut down the machine. The first 25 faults are recorded. The top number displayed represents the fault memory. The middle number represents the total number of faults that have occurred since the fault memory was cleared. To clear the memory, press and hold both the UP and DOWN arrows until the display is cleared.

Notes

- If the SELECT button is pressed and no parameters are changed by pressing the UP or DOWN arrow keys, the DTP-3 will automatically return to a display showing the line voltage.
- New settings are saved in permanent memory when the display returns to showing the line voltage. New settings may be verified by pressing the SELECT button to scroll through the parameters.
- To prevent tripping on a one (1) volt change, the DTP-3 automatically calculates cut-in voltages for the return from undervoltage conditions. The cut-out out voltage is always based on user voltage and tolerance settings, while the cut-in voltage is 3% closer to the nominal voltage setting. This quality is referred to as hysteresis. This is to help reduce oscillation that may occur on a weak power distribution system. When the load is switched off due to undervoltage, the line voltage will increase. Without hysteresis, the monitor would switch the load back on, the line voltage would again drop, and cause continuous on-off-on cycling.

Appendix B Tables

Table 21: HFO10 Specifications (460/400V, 3-phase, 60/50 Hz)

Tube Size		in. (mm)	1 (25)	1-1/4 (32)	1-1/2 (38)
Nominal Capacity ⁽¹⁾		lb/day (kg/day)	20,000 (9,072)	18,000 (8,165)	16,500 (7,484)
Overall Dimensions (L x W x H)		in. (m)	48 x 60 x 129 (1.2x1.5x3.3)	48 x 60 x 129 (1.2x1.5x3.3)	48 x 60 x 129 (1.2x1.5x3.3)
Shipping Weight		lb (kg)	4,800 (2,178)	4,800 (2,178)	4,800 (2,178)
Operating Weight		lb (kg)	5,200 (2,360)	5,200 (2,360)	5,200 (2,360)
Refrigerant Charge (R513A)		lb (kg)	470 (213)	470 (213)	470 (213)
Total FLA Water Cooled ⁽²⁾	60 Hz	Amps	44.0	44.0	44.0
	50 Hz	Amps	53.5	53.5	53.5
Total FLA Air Cooled ⁽²⁾	60 Hz	Amps	65.0	65.0	65.0
Maximum Fuse	60 Hz (WC/AC)	Amps	95/120	95/120	95/120
	50 Hz (WC)	Amps	115	115	115
Minimum Ampacity	60 Hz (WC/AC)	Amps	54/95	54/95	54/95
	50 Hz (WC)	Amps	65.6	65.6	65.6
Water Requirements					
-makeup ⁽³⁾		gpm (m ³ / hr)	3.0 (0.68)	3.0 (0.68)	3.0 (0.68)
-condenser ⁽⁴⁾		gpm (m ³ / hr)	80 (18.2)	80 (18.2)	80 (18.2)
Connection Sizes					
-makeup water		MPT in. (DN mm)	1/2 (15)	1/2 (15)	1/2 (15)
-tank drain		FPT in. (DN mm)	1 (25)	1 (25)	1 (25)
-condenser water inlet (standard)		FPT in. (DN mm)	2 (50)	2 (50)	2 (50)
-condenser water outlet (standard)		FPT in. (DN mm)	2-1/2 (65)	2-1/2 (65)	2-1/2 (65)
-AC condenser inlet		ODC in. (mm)	2-1/8 (54)	2-1/8 (54)	2-1/8 (54)
-AC condenser outlet		ODC in. (mm)	2-1/8 (54)	2-1/8 (54)	2-1/8 (54)
Compressor	60 Hz	HP/KW/RLA ⁽⁷⁾	35/26.1/40.3	35/26.1/40.3	35/26.1/40.3
	50 Hz	HP/KW/RLA ⁽⁷⁾	35/26.1/48.7	35/26.1/48.7	35/26.1/48.7
Water Pump	60 Hz	HP/KW/FLA	1.5/1.1/2.4	1.5/1.1/2.4	1.5/1.1/2.4
	50 Hz	HP/KW/FLA	2/1.5/3.6	2/1.5/3.6	2/1.5/3.6
Cutter Motor	60 Hz	HP/KW/FLA	0.5/0.4/0.92	0.5/0.4/0.92	0.5/0.4/0.92
	50 Hz	HP/KW/FLA	0.5/0.4/1.1	0.5/0.4/1.1	0.5/0.4/1.1

Tube Size	in. (mm)	1 (25)	1-1/4 (32)	1-1/2 (38)
THR	BTU/hr (kW)	275,000 (73.3)	275,000 (73.3)	275,000 (73.3)
Marley Cooling Tower ⁽⁵⁾		4822	4822	4822
-dim. (L x W x H)	ft (meters)	4 x 5 x 6.5 (1.2x1.5x2.0)	4 x 5 x 6.5 (1.2x1.5x2.0)	4 x 5 x 6.5 (1.2x1.5x2.0)
-shipping weight	lb (kg)	650 (295)	650 (295)	650 (295)
-operating weight	lb (kg)	1260 (571)	1260 (571)	1260 (571)
-fan	HP/KW/FLA	1/0.8/3.6	1/0.8/3.6	1/0.8/3.6
Tower Pump				
-flow	gpm (m ³ /hr)	78 (17.7)	78 (17.7)	78 (17.7)
-TDH minimum	ft (m)	80 (24.4)	80 (24.4)	80 (24.4)
-electrical data	HP/KW/FLA	3 /2.2/9.6	3 /2.2/9.6	3 /2.2/9.6
-connections (inlet x outlet)	FPT in. (DN mm)	4 x 3 (100 x 80)	4 x 3 (100 x 80)	4 x 3 (100 x 80)
-shipping weight	lb (kg)	65 (29.5)	65 (29.5)	65 (29.5)
Bohn Air-Cooled Condenser ⁽⁶⁾		BNHD06A044	BNHD06A044	BNHD06A044
- # of Fans / HP		6/1.5	6/1.5	6/1.5
- electrical data	total KW/FLA	11.5/42	11.5/42	11.5/42
-inlet connection	ODC in. (mm)	2-1/8 (54)	2-1/8 (54)	2-1/8 (54)
-outlet connection	ODC in. (mm)	2-1/8 (54)	2-1/8 (54)	2-1/8 (54)
-shipping weight	lb (kg)	2200 (999)	2200 (999)	2200 (999)
-operating weight	lb (kg)	1990 (903)	1990 (903)	1990 (903)

(1) Nominal capacity is based on 70°F (21°C) makeup water, 100°F (38°C) condensing temperature, 70°F (21°C) amb, and 0% blowdown.

(2) FLA for 230-volt models is approximately 2x that of 460-volt models. Total FLA does not include cooling tower.

(3) Makeup water is maximum value and includes 10 gallons (38 liters) per cycle blowdown.

(4) Condenser flow rate is for 85°F (29°C) entering water temperature and 100°F (38°C) condensing.

(5) Tower sized for 80°F (27°C) wet bulb temperature.

(6) Recommended air-cooled condenser is based on 15°F (8°C) TD.

(7) RLA=MCC/1.56

Vogt reserves the right to change designs and specifications without notice.

Table 22: HFO10 Capacity Chart, 50/60 Hz

Makeup Water Temp. (°F)	Rated Capacity (lb/day)						Makeup Water Temp. (°F)	Rated Capacity (lb/day)					
	Cylinder			Crushed				Cylinder			Crushed		
	1 in.	1-1/4 in.	1-1/2 in.	1 in.	1-1/4 in.	1-1/2 in.		1 in.	1-1/4 in.	1-1/2 in.	1 in.	1-1/4 in.	1-1/2 in.
40	21700	19100	17600	N/A	19864	18304	60	20600	18400	16900	N/A	19136	17576
41	21660	19080	17580	N/A	19843	18283	61	20540	18360	16860	N/A	19094	17534
42	21620	19060	17560	N/A	19822	18262	62	20480	18320	16820	N/A	19053	17493
43	21580	19040	17540	N/A	19802	18242	63	20420	18280	16780	N/A	19011	17451
44	21540	19020	17520	N/A	19781	18221	64	20360	18240	16740	N/A	18970	17410
45	21500	19000	17500	N/A	19760	18200	65	20300	18200	16700	N/A	18928	17368
46	21440	18960	17460	N/A	19718	18158	66	20240	18160	16660	N/A	18886	17326
47	21380	18920	17420	N/A	19677	18117	67	20180	18120	16620	N/A	18845	17285
48	21320	18880	17380	N/A	19635	18075	68	20120	18080	16580	N/A	18803	17243
49	21260	18840	17340	N/A	19594	18034	69	20060	18040	16540	N/A	18762	17202
40	21700	19100	17600	N/A	19864	18304	70	20000	18000	16500	N/A	18720	17160
41	21660	19080	17580	N/A	19843	18283	71	19830	17850	16350	N/A	18564	17004
42	21620	19060	17560	N/A	19822	18262	72	19660	17700	16200	N/A	18408	16848
43	21580	19040	17540	N/A	19802	18242	73	19490	17550	16050	N/A	18252	16692
44	21540	19020	17520	N/A	19781	18221	74	19320	17400	15900	N/A	18096	16536
45	21500	19000	17500	N/A	19760	18200	75	19150	17250	15750	N/A	17940	16380
46	21440	18960	17460	N/A	19718	18158	76	18980	17100	15600	N/A	17784	16224
47	21380	18920	17420	N/A	19677	18117	77	18810	16950	15450	N/A	17628	16068
48	21320	18880	17380	N/A	19635	18075	78	18640	16800	15300	N/A	17472	15912
49	21260	18840	17340	N/A	19594	18034	79	18470	16650	15150	N/A	17316	15756
50	21200	18800	17300	N/A	19552	17992	80	18300	16500	15000	N/A	17160	15600
51	21140	18760	17260	N/A	19510	17950	81	18130	16340	14850	N/A	16994	15444
52	21080	18720	17220	N/A	19469	17909	82	17960	16180	14700	N/A	16827	15288
53	21020	18680	17180	N/A	19427	17867	83	17790	16020	14550	N/A	16661	15132
54	20960	18640	17140	N/A	19386	17826	84	17620	15860	14400	N/A	16494	14976
55	20900	18600	17100	N/A	19344	17784	85	17450	15700	14250	N/A	16328	14820
56	20840	18560	17060	N/A	19302	17742	86	17280	15540	14100	N/A	16162	14664
57	20780	18520	17020	N/A	19261	17701	87	17110	15380	13950	N/A	15995	14508
58	20720	18480	16980	N/A	19219	17659	88	16940	15220	13800	N/A	15829	14352
59	20660	18440	16940	N/A	19178	17618	89	16770	15060	13650	N/A	15662	14196
							90	16600	14900	13500	N/A	15496	14040

- Capacity rating based on 70°F ambient conditions, 100°F SDT temperature.
- Capacity rating is average for the model. Individual machines may vary up to 5% above or below.
- Capacity rating is for clear ice production with makeup water containing no more than 200 ppm total dissolved solids.

Table 23: Condenser Water Usage

Condensing Temp. °F (°C)	Entering Water Temp. °F (°C)	Leaving Water Temp. °F (°C)	Water Flow gpm (m ³ /hr)	Pressure Drop psig (bar)	Average Total Heat of Rejection BTU/hr (kw)
100 (38)	50 (10)	110 (43)	9.5 (2.2)	0.9 (0.062)	275,000 (80.6)
100 (38)	55 (13)	109 (42.7)	10 (2.3)	1.0 (0.069)	275,000 (80.6)
100 (38)	60 (16)	108 (42)	12 (2.7)	1.3 (0.090)	275,000 (80.6)
100 (38)	65 (18)	105 (41)	14 (3.2)	1.8 (0.12)	275,000 (80.6)
100 (38)	70 (21)	103 (39)	17 (3.9)	2.7 (0.19)	275,000 (80.6)
100 (38)	75 (24)	100 (38)	22 (5.0)	4.7 (0.32)	275,000 (80.6)
100 (38)	80 (27)	97 (36)	34 (7.7)	11 (0.76)	275,000 (80.6)
100 (38)	85 (29)	93 (34)	70 (16)	48 (3.3)	275,000 (80.6)
105 (41)	90 (32)	95 (35)	110 (25)	119 (8.2)	275,000 (80.6)
110 (43)	95 (35)	92 (33)	110 (25)	119 (8.2)	275,000 (80.6)

Table 6: Makeup Water Usage

Makeup Water (10 gal [38 L]/cycle blowdown)	Cylinder Ice			Crushed Ice		
	Tube Size in. (mm)			Tube Size in. (mm)		
Temp. °F (°C)	1 (25)	1-1/4 (32)	1-1/2 (38)	1 (25)	1-1/4 (32)	1-1/2 (38)
40 (4)	2.56 (6.50)	2.25 (5.72)	2.19 (5.56)	3.00 (7.62)	2.62 (6.65)	2.54 (6.45)
50 (10)	2.49 (6.32)	2.21 (5.61)	2.14 (5.44)	2.92 (7.42)	2.58 (6.55)	2.49 (6.32)
60 (16)	2.42 (6.15)	2.16 (5.49)	2.09 (5.31)	2.84 (7.21)	2.53 (6.43)	2.43 (6.17)
70 (21)	2.35 (5.97)	2.12 (5.39)	2.04 (5.18)	2.74 (6.96)	2.47 (6.27)	2.38 (6.05)
80 (27)	2.14 (5.44)	1.93 (4.90)	1.86 (4.72)	2.49 (6.32)	2.25 (5.72)	2.16 (5.49)
90 (32)	1.93 (4.90)	1.74 (4.42)	1.68 (4.27)	2.25 (5.72)	2.02 (5.13)	1.94 (4.93)

Table 24: Normal Operating Criteria, English Units

			Suction Pressure (psig)	Discharge Pressure (psig)	Harvest Times (secs)			Ice per Cycle	Freeze Time (minutes)				
			End of Freeze	Average During Freeze	First	All Ice	Total	Average	Water Temperature (deg. F)				
			R513A	R513A	Ice	Out	Harvest	lb	90	80	70	60	50
50/60 Hz	Cylinder	1 in.	12	135	30	120	150	235	17.9	16.0	14.4	13.9	13.5
		1-1/4 in.	10	135	30	120	150	245	21.0	18.8	17.0	16.6	16.2
		1-1/2 in.	7	135	30	120	150	235	19.8	17.8	16.0	15.6	15.2
	Crushed	1 in.	N/A	N/A	N/A	N/A	N/A	N/A	N/A	N/A	N/A	N/A	N/A
		1-1/4 in.	16	135	15	105	150	175	13.7	12.1	10.9	10.6	10.3
		1-1/2 in.	13	135	15	105	150	175	13.3	11.8	10.6	10.3	10.0

Table 25: Normal Operating Criteria, Metric Units

			Suction Pressure (bar)	Discharge Pressure (bar)	Harvest Times (secs)			Ice per Cycle	Freeze Time (minutes)				
			End of Freeze	Average During Freeze	First	All Ice	Total	Average	Water Temperature (deg. C)				
			R513A	R513A	Ice	Out	Harvest	Kg	32	26.7	21	15.6	10
50/60 Hz	Cylinder	25 mm	0.83	9.31	30	120	150	107	17.9	16.0	14.4	13.9	13.5
		32 mm	0.7	9.31	30	120	150	111	21.0	18.8	17.0	16.6	16.2
		38 mm	0.5	9.31	30	120	150	107	19.8	17.8	16.0	15.6	15.2
	Crushed	25 mm	N/A	N/A	N/A	N/A	N/A	N/A	N/A	N/A	N/A	N/A	N/A
		32 mm	1.1	9.31	15	105	150	79.4	13.7	12.1	10.9	10.6	10.3
		38 mm	0.90	9.31	15	105	150	79.4	13.3	11.8	10.6	10.3	10.0

Table 26: 10TA Acceptance Ranges for R513A

Machine Type (All 50/60 Hz)			
Parameter	Tube Size in. (mm)		
	1 (25)	1-1/4 (32)	1-1/2 (38)
Minimum Ice Weight per Cycle (lb/kg)*	230/104	240/109	250/113
Maximum Ice Weight per Cycle (lb/kg)*	240/109	250/113	240/109
Minimum Ice Harvest Pressure (psig/bar)*	11/0.76	8/0.55	6/0.41
Maximum Harvest Pressure (psig/bar)*	14/0.96	12/0.8	9/0.62
DPS Setting, Close (psig/bar)	20/1.38	20/1.38	20/1.29
DPS Setting, Open (psig/bar)	42/2.9	42/2.9	42/2.9
Minimum Discharge Pressure** (psig/bar)	130/8.9	130/8.9	130/8.9
Maximum Discharge Pressure** (psig/bar)	140/9.6	140/9.6	140/9.6
Minimum Harvest Time (30 seconds out, minutes)	2.0	2.0	2.0
Maximum Harvest Time (minutes)	3.0	3.0	3.0
Low Pressure Safety Cutout (cut-out, psig/bar)	5/0.34	5/0.34	5/0.34
Low Pressure Safety Cutout (cut-in, psig/bar)	20/1.38	20/1.38	20/1.38
High Pressure Safety Cutout (cut-out, psig/bar)	200/13.8	200/13.8	200/13.8
High Pressure Safety Cutout (cut-in, psig/bar)	175/12	175/12	175/12

*Cylinder ice, DPS=defrost pressure switch

**Water-cooled

Table 27: HFO10 Spare Parts List

	Item	Vogt Part No.	Description	Qty.
Control Panel Parts	Cutter/Water Pump & PF (power failure) contactor	12A7516E23	Contactor (9Amp, 3 Pole, with 1 N.O. Aux, 208/240V Coil)	1
	Compressor Contactor (230V power)	12A7516E48	Compressor Motor Contactor (140 Amp, 3 Pole)	1
	Compressor Contactor (460V power)	12A7516E30	Compressor Motor Contactor (72 Amp, 3 Pole)	
	Compressor relay (400V power w/vfd)	12A7517E28	Compressor Relay for starting VFD	
	Aux contacts for CC (for 140A)	12A7518E43	Aux. Outside Contact (2 Amp, 2 N.O., Side Mount)	1
	Aux contacts for CC (for 72A)	12A7518E30	Aux. Contact (10 Amp, 1 NO/1NC, Side Mount)	1
		12A7518E31	Aux. Contact (10 Amp, 2 NO, Side Mount)	1
		12A7518E32	Aux. Contact (5 Amp, 2 NO, Top Mount)	1
	Control circuit fuses	12A7504E18	Fuse, 5A, 600V, Time Delay Class CC rejection type	2
	Water Pump	12A4020G01	Water pump, 1 1/2HP, 3-phase	1
	Cutter motor	12A2900M0508	Cutter motor, 1/2 hp, 3-phase	1
Cutter Tank Parts	Gear Reducer	12A4030R12	Grove, 10:1 gear reducer	1
	Makeup water float valve	12A4200H0402	Float valve, 1/2-in. (13 mm) MPT locknut & gasket, lead free brass	2
	Water distributor set	12B2185N31	Water distributor, 1 1/2-in. (38 mm) tubes	72
	Water distributor set Freezer cover gasket	12B2185N21	Water distributor, 1 1/4-in. (32 mm) tubes	102
	Water distributor set Freezer cover gasket	12B2185N11	Water distributor, 1-in. (25 mm) tubes	156
		12A2600G15	Gasket, gum rubber, freezer cover	1
	Cutter housing gasket (freezer flange to cutter tank)	12A2600G05	Gasket, cutter housing	1
	Water tank gasket (cutter assembled to tank)	12A2600G17	Gasket, gum rubber, water tank	1
	Water tank ice discharge splash curtain	12A4078C04	Splash curtain	1

HFO10 Spare Parts List, cont.

	Item	Vogt Part No.	Description	Qty.
Refrigeration Parts	Refrigerant float switch (electrical switch only)	12A7500E24	Refrigerant float switch, electrical switch only	1
	Suction gauge (150 psi) (10 bar)	12D2590G14	Gauge, 2.5-in. (64 mm), Liquid filled, 30-in. (76.2 cm) - 150 psi	1
	Discharge gauge (300 psi) (20 bar)	12D2590G15	Gauge, 2.5-in. (64 mm), Liquid filled, 30-in. (76.2 cm) - 150 psi	1
	Liquid line solenoid valve (A)	12A4200A0604 RS	RS valve, with 230V coil	1
	Thaw gas valve	12A4200A1204	Hansen valve. Less coil	1
	Thaw gas valve coil, Hansen	126229	Coil, Hansen, 208-240V	1
	Condenser Water regulating valve	12A4200E1402	Valve, condenser water regulating	1
Compressor Parts	Oil level control	12A2110P0507	Optical Oil level control, 230V control power	1
	Unloader coil	12A2110P0508	Coil, Unloader, 230V, 8W	1
	Crankcase Heater - 230V	12A7509E25	Crankcase Heater, 230V, 200W, for CSH65/75	1
	Electronic motor protection mod-STD	12A2110P0505	INT SE-E1 module for Compact Screw with no VFD, 115/230V	1
	Screw Compressor	12A2110Z052	Compressor, Screw, 35HP	1

Table 28: Control Panel Components and Part Numbers

Item No.	Vogt Part No.	Description
AX	12A7518E33UL	Aux. Trip Indicator, 6A, 1NO / 1NC
CB2	12A7515E22	Control Circuit Breaker, 6 Amp, 2 Pole (400V & 460V machines only)
CC 460V	12A7516E30	Compressor Motor Contactor (72 Amp, 3 Pole)
	12A7518E30	Aux. Contact (10 Amp, 1 N.O./1 N.C., Side Mount)
	12A7518E31	Aux. Contact (10 Amp, 2 N.O., Side Mount)
	12A7518E32	Aux. Contact (5 Amp, 2 N.O., Top Mount)
CC 208/230V	12A7516E48	Compressor Motor Contactor (140 Amp, 3 Pole)
	12A7518E43	Aux. Outside Contact (2 Amp, 2 N.O., Side Mount)
	12A7518E44	Aux. Inside Contact (2 Amp, 2 N.O., Side Mount)
CC 400V (50 Hz)	12A7517E28	Compressor Control Relay (10A, 3 N.O./1 N.C., 208/240V Coil)
	12A7518E31	Aux. Contact (10A, 2 N.O., Side Mount)
CCR	12A7517E27	Unloader Relay
CR	12A7517E27	Control Relay (10 Amp, 2 N.O./2 N.C., 208/240V Coil)
CU	12A7516E23	Contactor (9Amp, 3 Pole, with 1 N.O. Aux, 208/240V Coil)
	12A7530E52UL	Cutter Manual Motor Starter, 0.63-1.0A (460V, 60 Hz)
	12A7530E53UL	Cutter Manual Motor Starter, 1.0-1.6A (400V, 50 Hz)
	12A7530E54UL	Cutter Manual Motor Starter, 1.6-2.5A (200/208/230V, 50/60 Hz)
ET	12B7503E17	Timer, Elapsed, Panel Mount, 220V (50Hz)
	12B7503E18	Timer, Elapsed, Panel Mount, 220V (60Hz)
FC Air-Cooled Only	12A7516E27	Condenser Fan Contactor (30 Amp, 3 Pole, 1 N.O. Aux. Contact, 208/240V Coil)
	12A7530E58UL	Fan Manual Motor Starter, 10.0-16.0A (400/460V, 50/60 Hz)
	12A7530E63UL	Fan Manual Motor Starter, 23.0-32.0A (200/208/230V, 50/60 Hz)
FU1 & FU2	12A7504E18	Fuses, 5A, 600V, Class CC, Time Delay
FU10-FU60	12A7504E29	Fuses, 1A, 600V, Class CC, Fast Acting (For optional Power Monitor)
P	12A7516E23	Contactor (9Amp, 3 Pole, with 1 N.O. Aux, 208/240V Coil)
	12A7530E55UL	Pump Manual Motor Starter, 2.5-4.0A (400V/460V, 50/60 Hz)
	12A7530E56UL	Pump Manual Motor Starter, 4.0-6.3A (208/230V, 60 Hz)
	12A7530E57UL	Pump Manual Motor Starter, 6.5-10.0A (200V only)
PBL1	12A7500E79	Contact Block/Mounting Latch (2 N.C.)
	12A7500E157	Light Module, Red LED, 240V
	12A7500E158	Lighted Push Button (Red)

Control Panel Components and Part Numbers, cont.

Item No.	Vogt Part No.	Description
PB2	12A7500E56	Start Push Button (Green)
	12A7500E73	Contact Block/Mounting Latch (2 N.O.)
PM	12A7700P01	Power Monitor, Universal Phase Protector (Optional)
PF	12A7516E23	Power Failure Contactor (9 Amp, 3 Pole, 1 N.O. Aux. Contact, 208/240V Coil)
SS	12A7500E61	Selector Switch, 3 Position
	12A7500E77	Contact Block/Mounting Latch (2 N.O./1 N.C.)
T	12A7503E22	Thawing Timer (Delay On Make) 100-240V
	12A7503E39	Timer Base (8 Pin, Guarded Terminal)
TB1	N/A	Main Terminal Block Assembly

Table 29: Temperature – Pressure Chart for R513A

Deg (°F)	Sat Liq P (psig)	Sat Vap P (psig)	Deg (°F)	Sat Liq P (psig)	Sat Vap P (psig)	Deg (°F)	Sat Liq P	Sat Vap P	Deg (°F)	Sat Liq P	Sat Vap P
-40	-5.9	-6	25	26	26	66	71.3	71.3	107	147.1	147.1
-35	-4.6	-4.7	26	26.8	26.8	67	72.7	72.7	108	149.4	149.4
-30	-3.1	-3.2	27	27.6	27.6	68	74.2	74.2	109	151.8	151.8
-25	-1.5	-1.6	28	28.5	28.4	69	75.7	75.7	110	154.1	154.1
-20	0.2	0.1	29	29.3	29.3	70	77.2	77.2	111	156.5	156.5
-15	2.2	2.1	30	30.2	30.2	71	78.7	78.7	112	159	158.9
-10	4.3	4.3	31	31.1	31.1	72	80.2	80.2	113	161.4	161.4
-9	4.8	4.7	32	32	32	73	81.8	81.8	114	163.9	163.8
-8	5.2	5.2	33	32.9	32.9	74	83.4	83.4	115	166.4	166.3
-7	5.7	5.6	34	33.8	33.8	75	85	85	116	168.9	168.9
-6	6.2	6.1	35	34.8	34.7	76	86.6	86.6	117	171.4	171.4
-5	6.7	6.6	36	35.7	35.7	77	88.2	88.2	118	174	174
-4	7.2	7.1	37	36.7	36.6	78	89.9	89.9	119	176.6	176.6
-3	7.7	7.6	38	37.7	37.6	79	91.5	91.5	120	179.3	179.2
-2	8.2	8.1	39	38.6	38.6	80	93.2	93.2	121	181.9	181.9
-1	8.7	8.7	40	39.7	39.6	81	94.9	94.9	122	184.6	184.6
0	9.3	9.2	41	40.7	40.7	82	96.7	96.7	123	187.3	187.3
1	9.8	9.7	42	41.7	41.7	83	98.4	98.4	124	190	190
2	10.4	10.3	43	42.8	42.7	84	100.2	100.2	125	192.8	192.8
3	10.9	10.9	44	43.8	43.8	85	102	102	126	195.6	195.6
4	11.5	11.4	45	44.9	44.9	86	103.8	103.8	127	198.4	198.4
5	12.1	12	46	46	46	87	105.7	105.7	128	201.3	201.2
6	12.7	12.6	47	47.1	47.1	88	107.5	107.5	129	204.2	204.1
7	13.3	13.2	48	48.2	48.2	89	109.4	109.4	130	207.1	207
8	13.9	13.8	49	49.4	49.4	90	111.3	111.3	131	210	209.9
9	14.5	14.4	50	50.5	50.5	91	113.2	113.2	132	213	212.9
10	15.1	15.1	51	51.7	51.7	92	115.2	115.2	133	216	215.9
11	15.8	15.7	52	52.9	52.9	93	117.1	117.1	134	219	218.9
12	16.4	16.4	53	54.1	54.1	94	119.1	119.1	135	222.1	222
13	17.1	17.1	54	55.3	55.3	95	121.1	121.1	140	237.8	237.7
14	17.8	17.7	55	56.6	56.5	96	123.2	123.2	145	254.3	254.2
15	18.5	18.4	56	57.8	57.8	97	125.2	125.2	150	271.6	271.5
16	19.2	19.1	57	59.1	59.1	98	127.3	127.3			
17	19.9	19.8	58	60.4	60.4	99	129.4	129.4			
18	20.6	20.6	59	61.7	61.7	100	131.5	131.5			
19	21.3	21.3	60	63	63	101	133.7	133.7			
20	22.1	22	61	64.3	64.3	102	135.9	135.9			
21	22.8	22.8	62	65.7	65.7	103	138.1	138.1			
22	23.6	23.6	63	67.1	67.1	104	140.3	140.3			
23	24.4	24.4	64	68.5	68.5	105	142.5	142.5			
24	25.2	25.1	65	69.9	69.9	106	144.8	144.8			

Table 30: Constants

Specific Heat of Water	1 BTU/(lbm °F) 1 calorie/gram °C
Specific Heat of Air	4.19 Kj/(kg °C) 0.24 BTU/(lbm °F)
Tube-Ice Density	32-35 lb/ft ³ 0.51-0.56 gm/cm ³
Ice Latent Heat	144 BTU/hr (42 watts/hr)
Water Sensible Heat	1 BTU/(lb °F) (4,182 Joules/kg °C)
Ice Melting Effect 1 Ton Refrigeration	12,000 BTU/hr (3.5 kw/hr)
Atmospheric Pressure	14.7 psia (760 mmHg)
Weight of Water	62.4 lb/ft ³ 1,000 kg/m ³ 8.33 lb/gal
1 gpm Water 3.79 L/min	12,013 lb/day 5,449 kg/day
Weight of Air	0.0749 lb/ft ³ (0.0100 lb/gal)
1 Horsepower	2,545.6 BTU/hr (46 watts)
1 Kilowatt	1.34 horsepower 3,411 BTU/hr
Gravitational Acceleration	9.81 m/sec ²

Appendix C Additional Documentation

The following lists other documents for your reference.

- OSHA Standard: The Control of Hazardous Energy (Lockout/Tagout) (29 CFR 1910.147)
- R513A Safety Data Sheet
- Bitzer CSH Compressor Manual
- Water Conditioning Technical Service Bulletin 88-5
- Compressor Oil BSE-170 Safety Data Sheet
- Gear Reducer Oil Safety Data Sheet



Vogt Ice®, LLC
1000 W. Ormsby Ave.
Suite 19
Louisville, KY 40210 USA
Since 1880