

REVISION RECORD				
NO	DATE	FROM	TO	BY

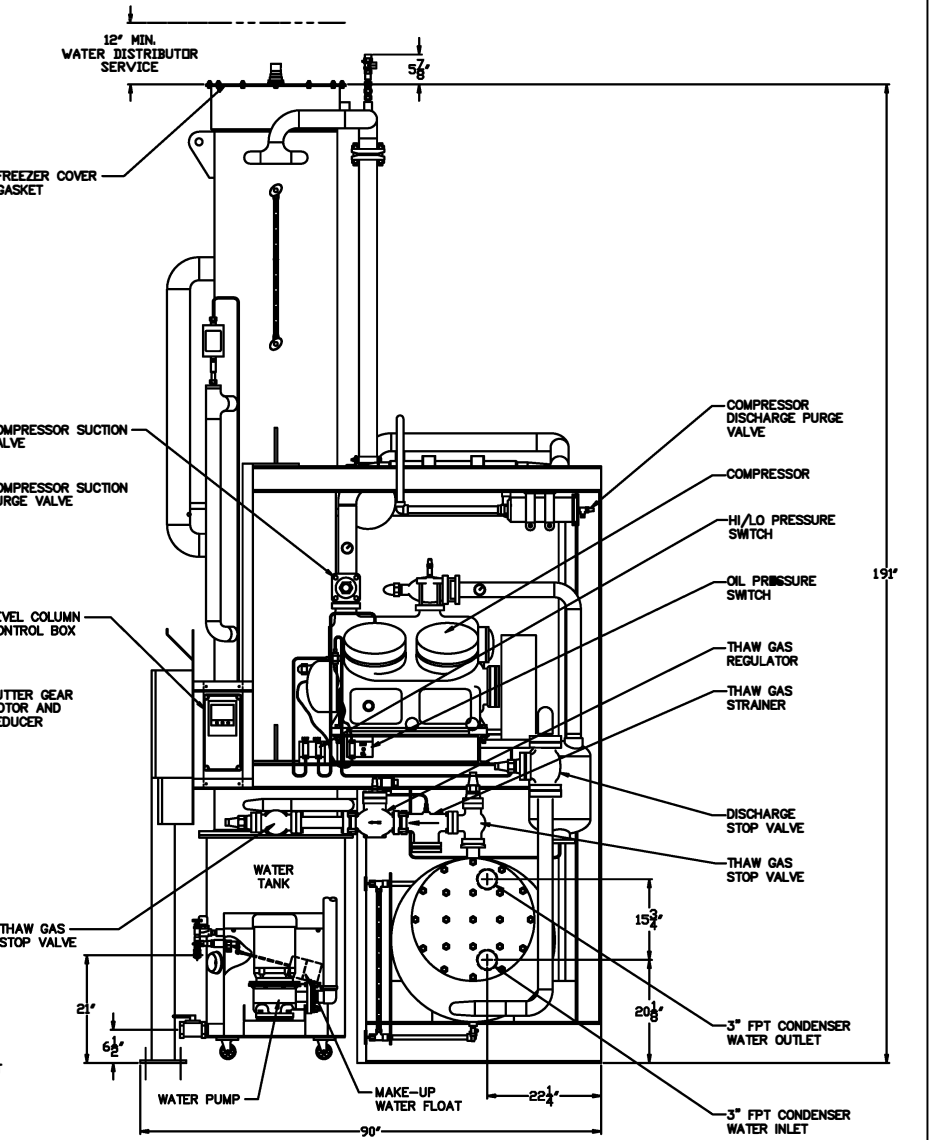
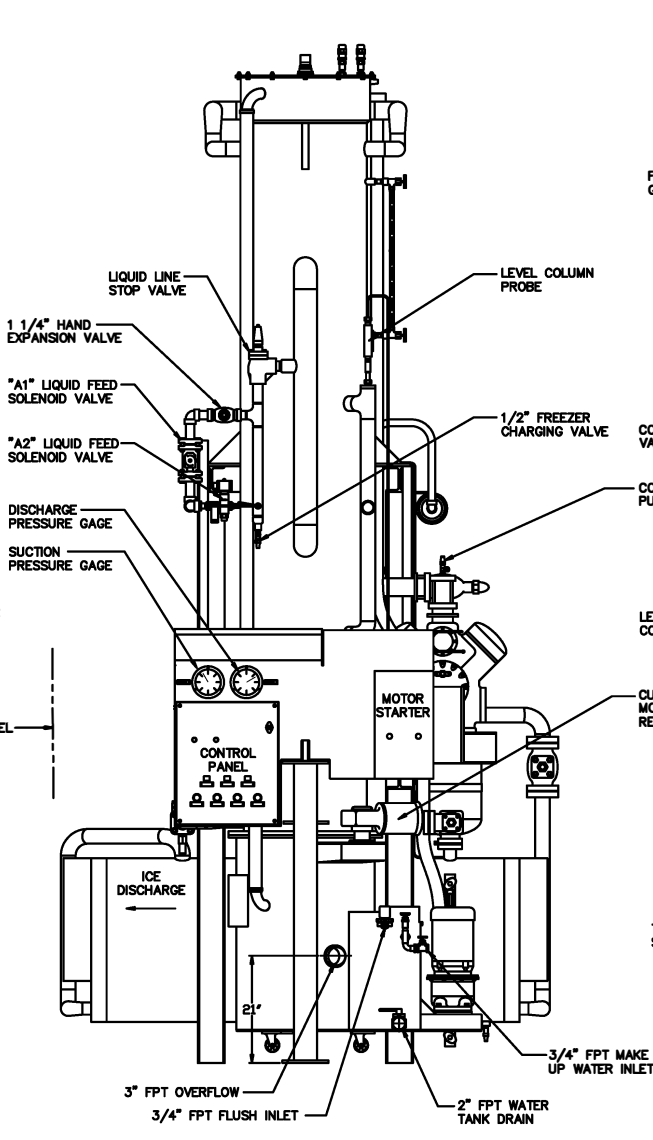
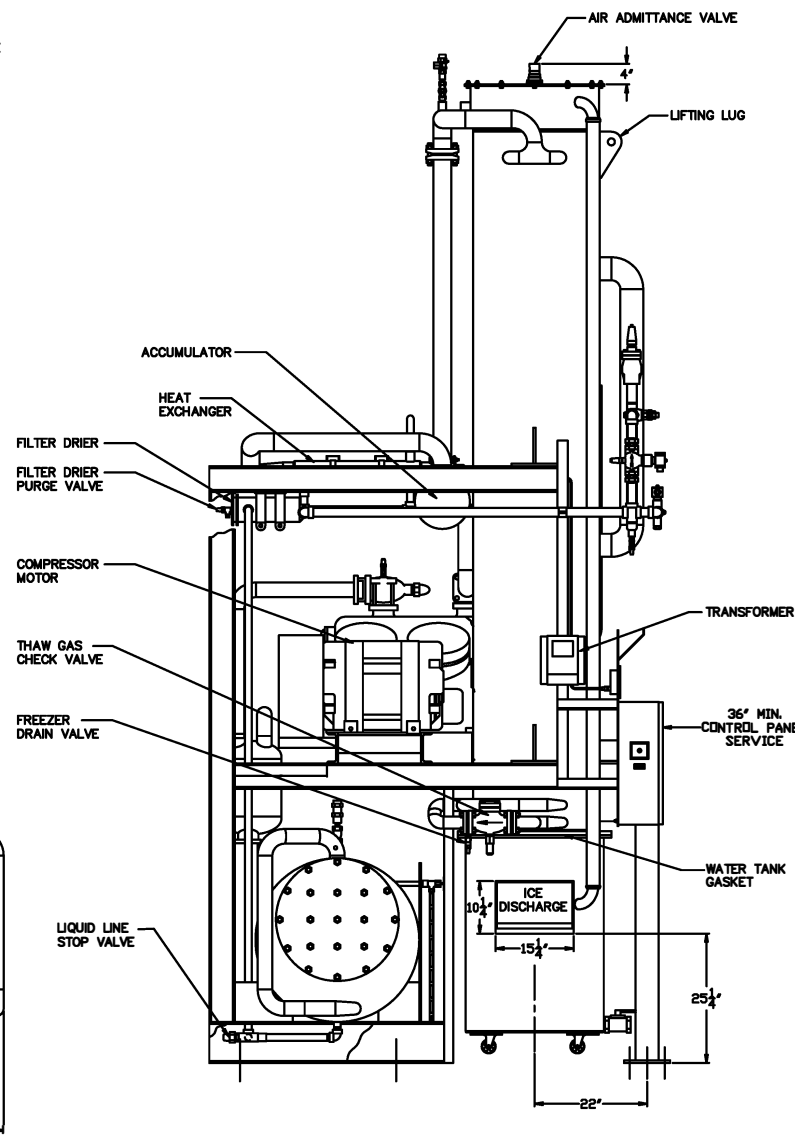
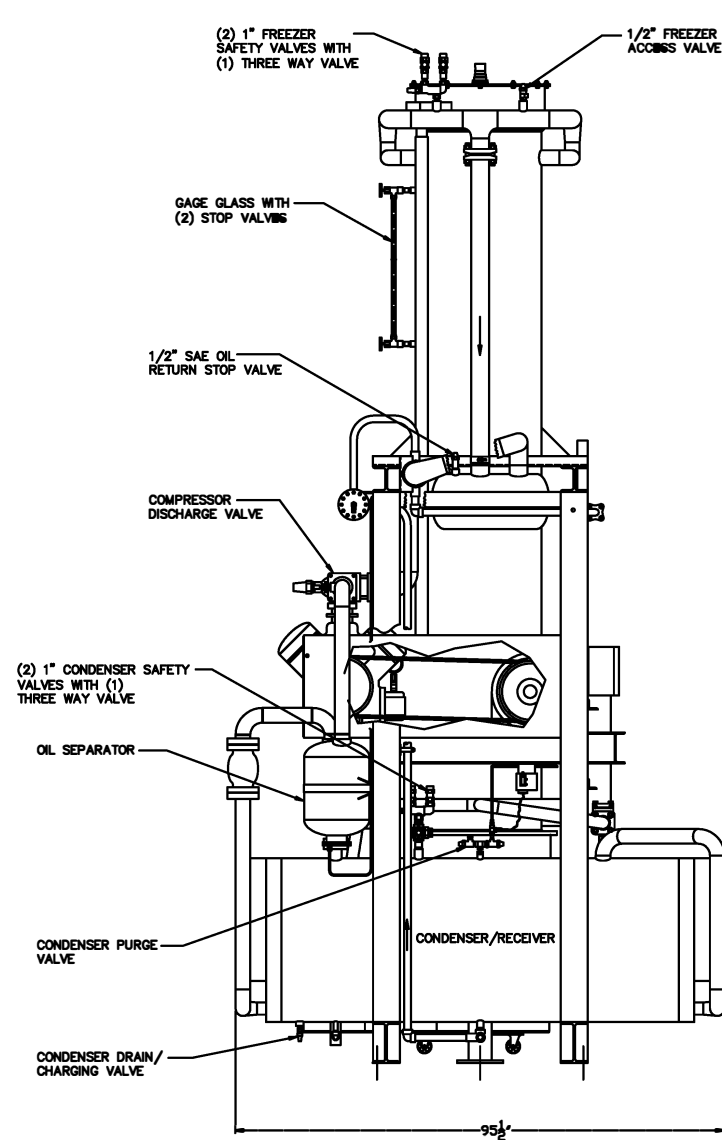
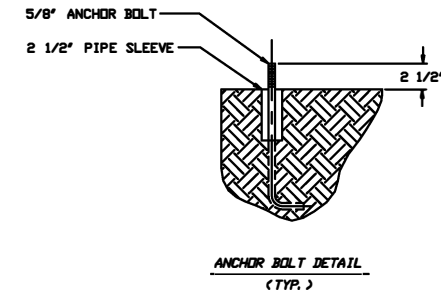
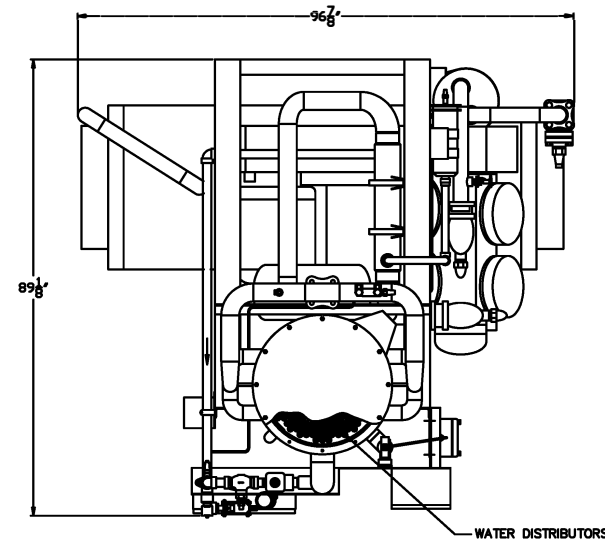
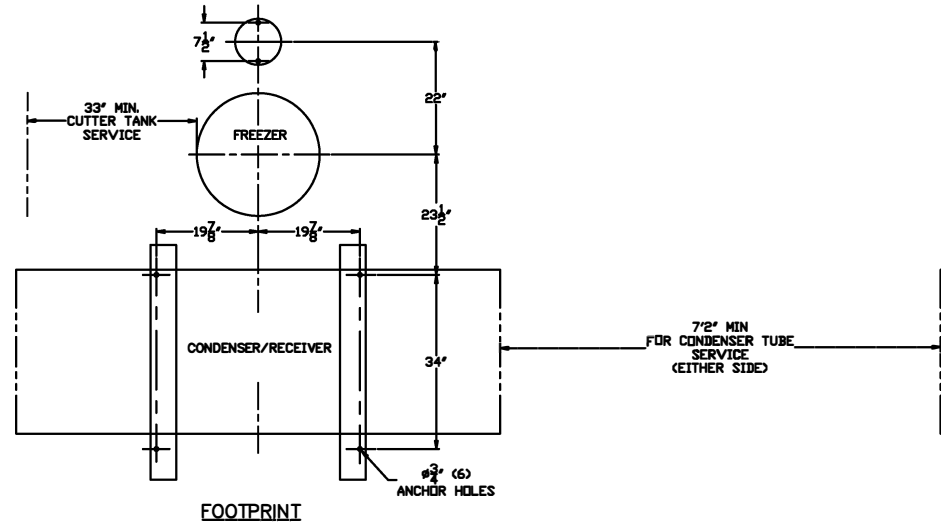

This drawing contains TRADE SECRETS and confidential information of Tube Ice, LLC. It is to be used only for the purpose intended and is not to be distributed or copied in whole or in part, without the express written consent of Tube Ice, LLC.

Copyright © 2005 Tube Ice, LLC. All rights reserved. No part of this drawing may be reproduced without the written consent of Tube Ice, LLC.

DWN. BY LOGSDON  
 CKD. BY  
 FLSD. BY  
 DATE 06/03/05  
 SCALE NONE

**Tube ICE, LLC**  
 1000 W. CRMSBY AVE., LOUISVILLE, KY. 40210

CUSTOMER ASSEMBLY  
 FOR P24F TUBE-ICE MACHINE

DRG. NO. 81732