

**Vogt**<sup>®</sup>

***Tube-Ice***<sup>®</sup>

# Air-Cooled Condenser

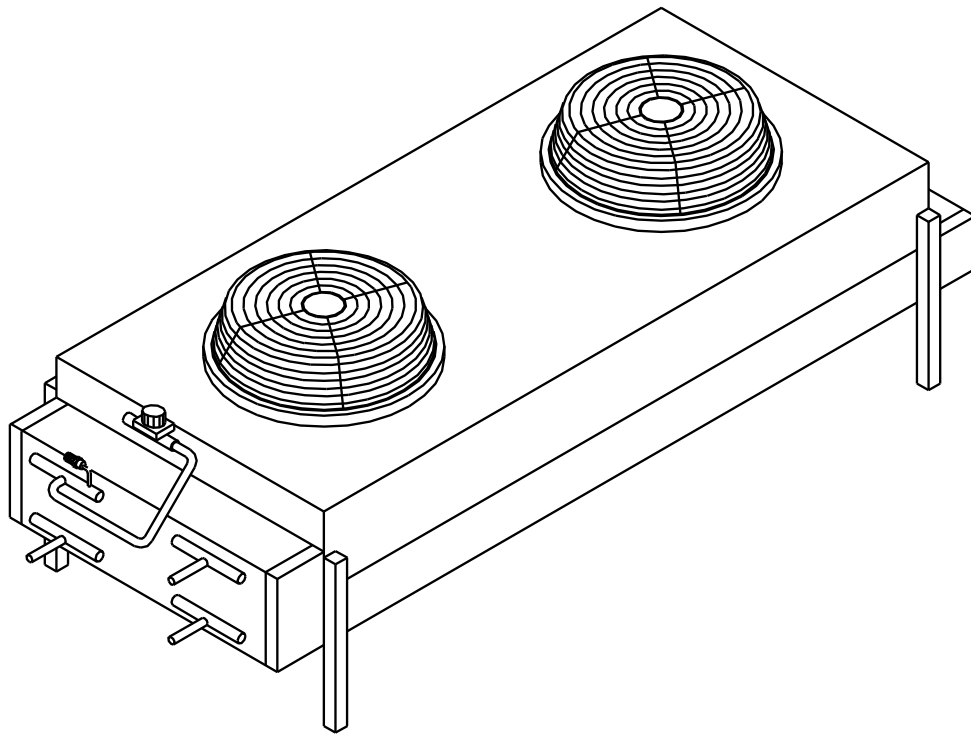

# Installation Instructions

**! WARNING !**

**These installation guidelines must be followed to obtain reliable operation from air-cooled ice machines. If these guidelines are not followed, the compressor warranty will not be honored.**

**! WARNING !**

1. Use only Vogt approved condensers. Any exceptions to this policy must be obtained in writing prior to installation and operation of the ice machine.
2. Outdoor condensers **must** be installed with vertical airflow. Indoor condensers used for heat recovery may be installed with either horizontal or vertical airflow.
3. The condenser **must** be mounted above the ice machine, with liquid refrigerant from the condenser outlet draining freely (1/4" per foot slope) in the direction of normal operating flow (back to the ice machine) with no traps in the liquid line.
4. Flooding head pressure controls such as Alco Headmaster are **not** to be used, since they cause excessive sub cooling of the returned liquid refrigerant and interfere with reliable ice harvest.
5. The discharge and liquid lines must be insulated with 1/2" thick Armaflex insulation or equal.
6. **Horizontal runs in the discharge** line should slope 1/4" per foot in the normal direction of flow (away from the ice machine).
7. Traps must be installed in discharge lines at the base of all vertical risers. There should be no intentional traps in liquid lines. Trap volume should be kept to a minimum. Typical details are shown in FIGURE-10. Long vertical runs should have traps every 20 feet.
8. Use only ACR grade copper pipe, Type L. Recommended line sizes are shown in TABLE-3.
9. Distance between ice machine and condenser must not exceed 150 equivalent feet. Refer to Condenser Equivalent Line Size worksheet. (see TABLE-5)
10. Condensers must be provided with a cold weather valve kit per FIGURE-9A. These valves allow one-half of the condensers to be disabled in cold weather. Running the ice machine with one half the condenser in cold weather makes it easier to maintain minimum necessary condensing pressure, particularly in windy conditions. The coil thermostat should be set to close at 35°F for multiple fan condensers or 50°F for single fan condensers.
11. Condensers with multiple fans must be provided with a thermostat to turn off unneeded fans in cold weather. Turning off unneeded fans reduces on-off cycling of the fan(s) and allows for a steadier condensing pressure. The fan thermostat should be set at 50°F.
12. When extreme cold conditions are expected or encountered (temperatures below 0°F and wind greater than 15 MPH), it may be necessary to install a protective enclosure around the condenser. Other apparatuses such as louvers may be used. Contact the factory for suggestions.

13. After installation, the field-installed lines are to be evacuated to a vacuum of 500 microns or less and held for at least one hour. Use ¼” access connection located on compressor discharge line and liquid return line (32). After the vacuum pump is removed, vacuum should hold at 500 microns or less for at least 5 minutes and the lines pressurized with refrigerant to 25-psig minimum.
14. The volume of refrigerant supplied with the machine is sufficient to fill the condenser and condenser lines when length of pipe (one way) is 75 feet or less. When the length of lines is longer than 75 feet, additional refrigerant must be added as noted below. Instructions for adding refrigerant are included further in these instructions.

<b>Liquid Line Size</b>	<b>75 ft.</b>	<b>100 ft.</b>	<b>125 ft.</b>	<b>150 ft.</b>
1/2”	none	None	None	2
5/8”	none	2	4	6
7/8”	none	4	8	12
1-1/8”	none	6	12	18

**TABLE - 3**  
**Pounds Refrigerant to Add Vs. Liquid Line Length**

15. All piping must be done in accordance with applicable local and national codes. Such codes may include “The Safety Code for Mechanical Refrigeration (ANSI B9.1), and “The Code for Refrigerant Piping” (ANSI B31.5).
16. The following installation guidelines are strongly suggested. While they do not affect the machine warranty, they may be required for safe operation, and to comply with all applicable electrical and mechanical codes.
17. Local electrical code must be checked for wiring method.
18. The installer must provide a lockable disconnect switch(s) adjacent to the condenser. The power is fused at the machine by a 15-amp breaker.
19. Electrical connections between the condenser and the Tube-Ice® machine require minimum 12 ga. wires. See FIGURE-11 &12.
20. All electrical fittings and components exposed to the weather must be suitable for outdoor installation.

The design total heat rejection for each Tube-Ice® machine, the recommended air-cooled condenser, and condenser physical and electrical data are shown in TABLE-2. Only the condensers shown are UL listed with the ice machines. Other condensers may be individually UL listed, but are not UL listed with the Tube-Ice® machines, and cannot be recommended by Vogt Tube-Ice. Catalog energy efficiency ratings of the ice machines are based on use of the recommended condenser.

Condensers supplied by Vogt must be utilized. The use of non-Vogt condensers will void the compressor warranty. For continuous operation at ambient above 105°F, consult the factory about using a larger condenser.

Ice Machine Model	HE20	HE30	HE40	HFO3
Recommended Condenser	DVT005 (DVT008)	DVT008 (DVT012)	DVT012 (DVT016)	BNHS02A011 (BNHS02A011(12))
	<b>Note:</b> For continuous operation at ambient above 95 °F, use larger condenser shown in parenthesis			
Total Heat Rejection: BTU/hr at 60 Hz. (15°F TD) BTU/hr at 50 Hz.	35,700 32,800	58,800 54,100	117,500 108,100	157,500 (172,500) 144,900 (159,700)
Fans: Number HP, Each Total, CFM	1 1/3 (1/2) 5,050 (6,450)	1 (2) 1/2 6,450 (12,400)	2 1/2 12,400 (12,900)	2 1.5 20,500
Full Load Amps: 1 ph., 208/230V, 60 Hz 3 ph., 208/230V, 60 Hz 3 ph., 460V, 60 Hz 1 ph., 200/220V, 50 Hz 3 ph., 200/220V, 50 Hz 3 ph., 400V, 50 Hz	3.4 (3.9) N/A 1.3 (1.3) 3.4 (3.9) N/A 1.3 (1.3)	3.9 (7.8) N/A 1.3 (2.6) 3.9 (7.8) N/A 1.3 (2.6)	7.8 (7.8) N/A 2.6 (2.6) 7.8 (7.8) N/A 2.6 (2.6)	N/A 14.0 7 N/A 14.0 7
Weight, lbs.: Net Shipping Operating (maximum flooded)	180 (260) 320 (390) 195 (285)	260 (470) 390 (520) 285 (500)	470 (530) 520 (680) 500 (560)	580 (585) 760 (765) 610 (615)
Condenser dimensions, inches: A (Width) B (Length) C (Height) D (Leg centerline) E (Leg centerline) F (Clearance below)	43" 39.75" (49.75") 30" (40") 17"-3 30" (40") 24.5"	43" 49.75" (69.75") 40" (60") 17" - 3 40" (60") 24.5"	43" 69.75" 60" 17" - 3 60" 24.5"	45.46" 127" 49.15" 38" 106.15" 20.5"
Recommended Line Sizes, OD: Liquid (All lengths & orientations) Discharge Gas Vertical Up, All lengths Horizontal Or Down, < 75 ft. Horizontal Or Down, > 75 ft.	1/2"  5/8" 5/8" 7/8"	5/8"  7/8" 7/8" 1-1/8"	7/8"  1-1/8" 1-1/8" 1-3/8"	7/8"  1-1/8" 1-1/8" 1-3/8"
Connections at Condenser: Liquid (ODC) Discharge Gas (ODC) Connections at Machine Liquid (ODC) Discharge Gas (ODC)	5/8"(7/8") 7/8" (1 1/8")  1-1/8" 1-1/8"	7/8" 1 1/8"  1-1/8" 1-1/8"	7/8" (1-1/8") 1-1/8" (1-3/8")  1-1/8" 1-1/8"	1-1/8" 1-3/8"  1-1/8" 1-1/8"

**TABLE - 4**  
**Air-Cooled Condenser Data**

Ice Machine Model	P118F	HFO5	P18FXT	HFO10
Recommended Condenser	BNHS02A015(8) (BNHS02A015(12))	BNHS02A017 (BNHS03A026)	BNHS04A029	BNHD06A044
<b>Note:</b> For continuous operation at ambient above 95 °F, use larger condenser shown in parenthesis				
Total Heat Rejection: BTU/hr at 60 Hz. (15°F TD) BTU/hr at 50 Hz.	192,000 (229,500) 176,600 (211,100)	232,000	427,500 393,300	642,000 534,000
Fans:				
Number	2	2 (3)	4	6
HP, Each	1.5	1.5	1.5	1.5
Total, CFM	19,800	19,000 (28500)	38,600	59,400
Full Load Amps:				
1 ph., 208/230V, 60 Hz	N/A	N/A	N/A	N/A
3 ph., 208/230V, 60 Hz	14	14 (21)	28	42
3 ph., 460V, 60 Hz	7	7 (10.5)	14	21
1 ph., 200/220V, 50 Hz	N/A	N/A	N/A	N/A
3 ph., 200/220V, 50 Hz	14	14 (21)	28.0	42
3 ph., 400V, 50 Hz	7	7 (10.5)	14	21
Weight, lbs.:				
Net	625 (635)	680 (1,000)	1210	1980
Shipping	805 (815)		1520	1980
Operating (maximum flooded)	680 (690)		1265	2010
Condenser dimensions, inches:				
A (Width)	45.46"	45.46" (45.46")	45.46"	88"
B (Length)	127"	127" (164.71")	233.16"	180"
C (Height)	49.15"	49.13" (49.13")	49.15"	49.13"
D (Leg centerline)	38"	38" (38")	38"	53"
E (Leg centerline)	106.15"	106.15" (53"-3)	*106.15" (3)	*159" (3)
F (Clearance below)	20.5"	20.5" (20.5")	20.5"	23.25"
Recommended Line Sizes, OD:				
Liquid (All lengths & orientations)	1-1/8"	1-1/8"	1-3/8"	1-3/8"
Discharge Gas				
Vertical Up, All lengths	1-3/8"	1-3/8"	1-5/8"	1-5/8"
Horizontal Or Down, < 75 ft.	1-3/8"	1-3/8"	1-5/8"	1-5/8"
Horizontal Or Down, > 75 ft.	1-5/8"	1-5/8"	2-1/8"	2-1/8"
Connections at Condenser:				
Liquid (ODC)	1-1/8"	2-1/8"	1-3/8"	2-1/8"
Discharge Gas (ODC)	1-5/8"	2-1/8"	2-1/8"	2-1/8"
Connections at Machine:				
Liquid (ODC)	1-1/8" (1-1/4"-12)	1-1/8" (1-1/4"-12)	1-1/8" (1-1/4"-12)	1-1/8" (1-1/4"-12)
Discharge Gas (ODC)	1-3/8" (1-3/4"-12)	1-3/8" (1-3/4"-12)	1-3/8" (1-3/4"-12)	1-3/8" (1-3/4"-12)

\* Note: Condenser has legs in middle

**TABLE – 4A**  
**Air-Cooled Condenser Data**

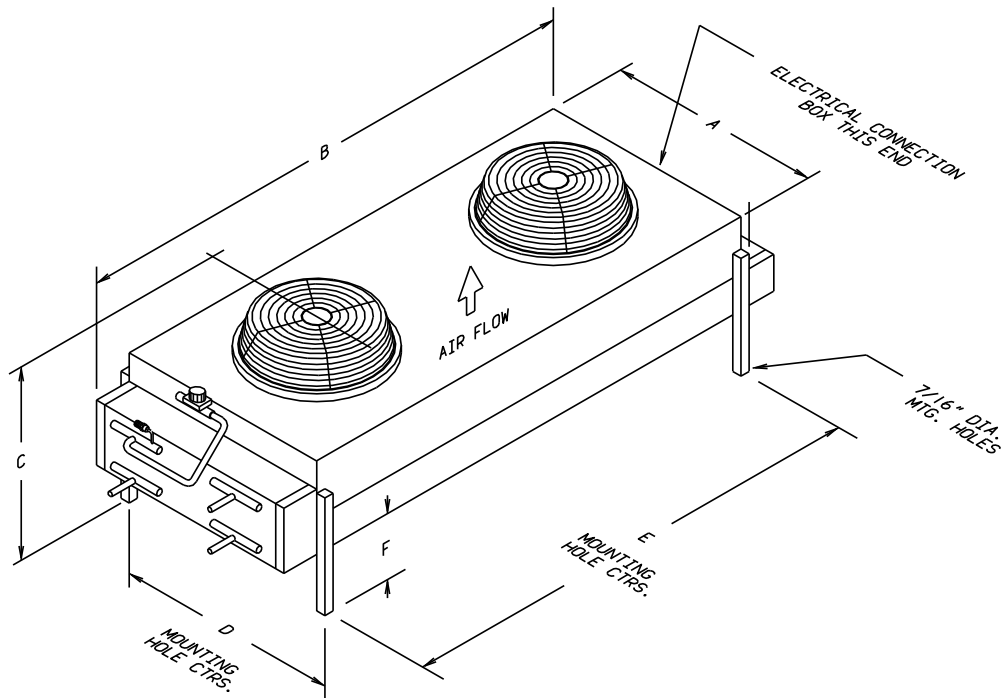

**FIGURE - 9**  
**Condenser Dimensions**

Machine	Bohn Part #	Vogt Part #	Coil Split
HE20	DVT005	12A2115B03	50/50
HE30 & HE20 (High Ambient)	DVT008	12A2115B04	50/25/25
HE40 & HE30 (High Ambient)	DVT012	12A2115B05	50/50
HE40 (High Ambient)	DVT016	12A2115B06	50/50
P112	BNHS02A011	12A2115B07	50/50
P112 (High Ambient)	BNHS02A011(12)	12A2115B08	50/50
P118	BNHS02A015(8)	12A2115B09	50/25/25
P118 (High Ambient)	BNHS02A015(12)	12A2115B10	50/25/25
HFO5 / HFO10 1-3/4"	BNHS02A017	12A2115B117	50/25/25
HFO5 (High Ambient)	BNHS03A026	12A2115B16	50/50
P18XT	BNHS04A029	12A2115B11	50/50
HFO10	BNHD06A044	12A2115B15	50/50
HFO10 (Low Ambient)	BNHS04A029	*12A2115B115LA	50/25/25

Note: Condensers listed above are 200/208/230V, 50/60 Hz. 400/460V, 50/60 Hz available

\*Note: Low Ambient condenser listed is 575V, 60Hz

**TABLE - 5**

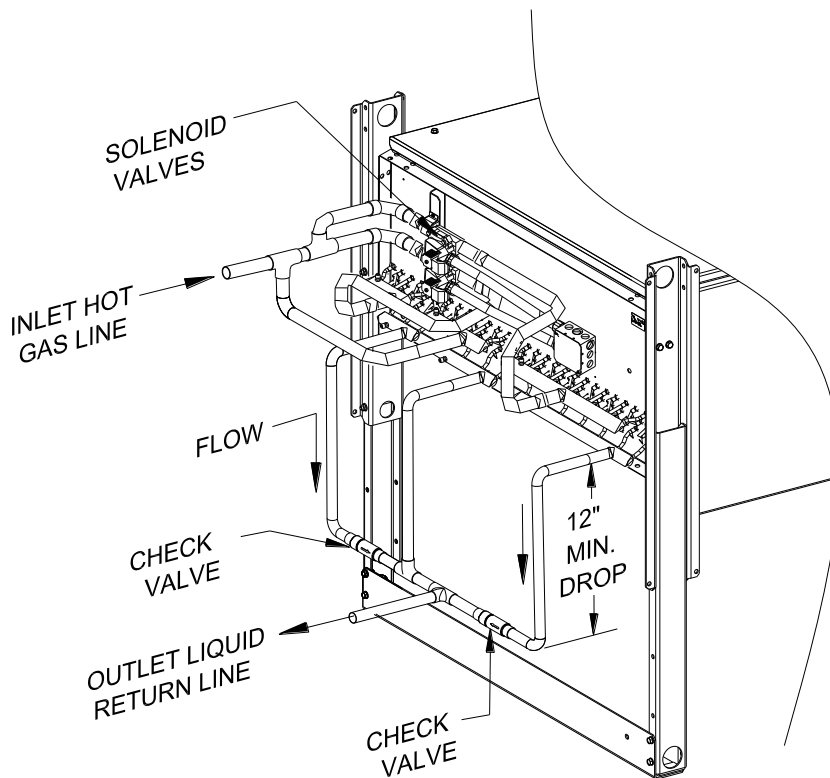
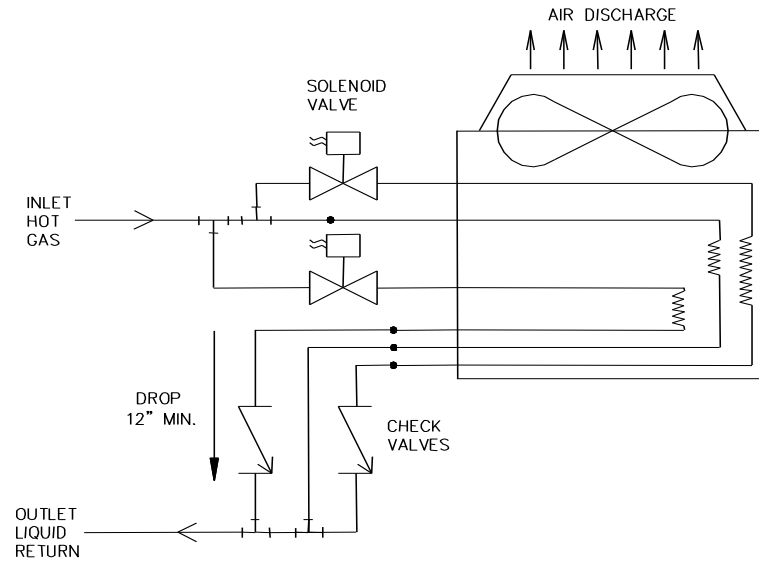

**Note:** Dash lines indicate customer supplied piping. The Check Valves in the return line (labeled “Output Liquid Return Line”) is supplied with the condenser.

**FIGURE – 9A**

### Condenser Field Piping / 50-25-25 Coil Split

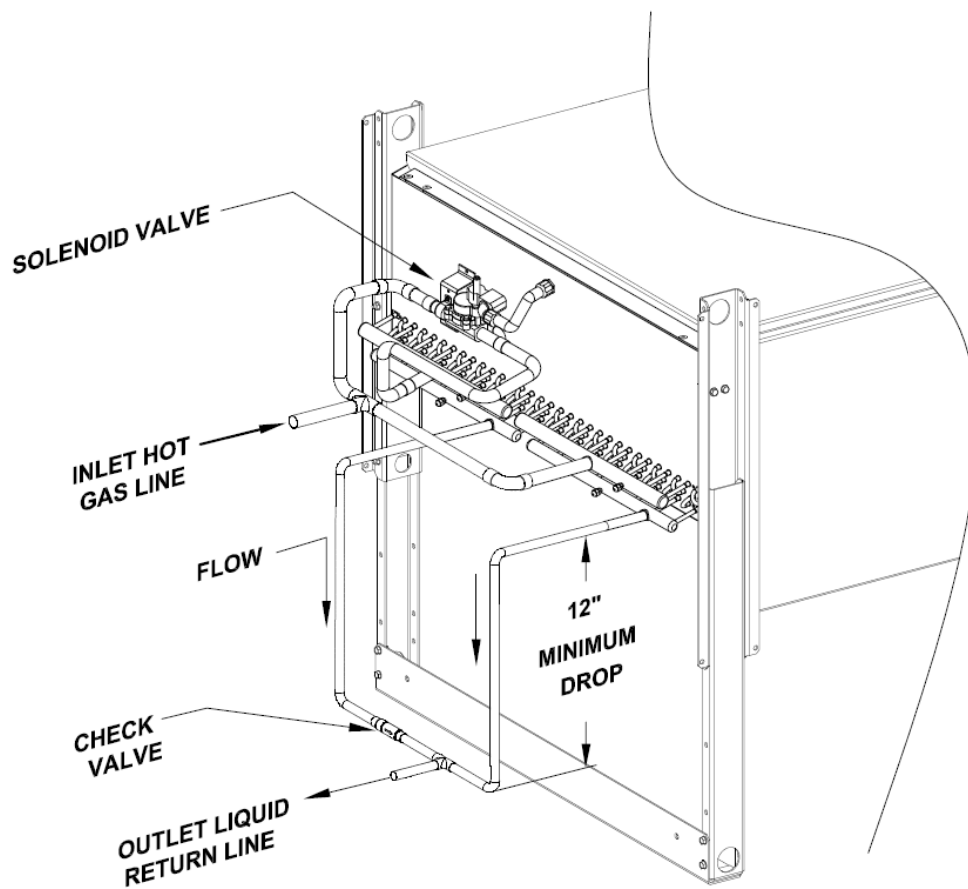
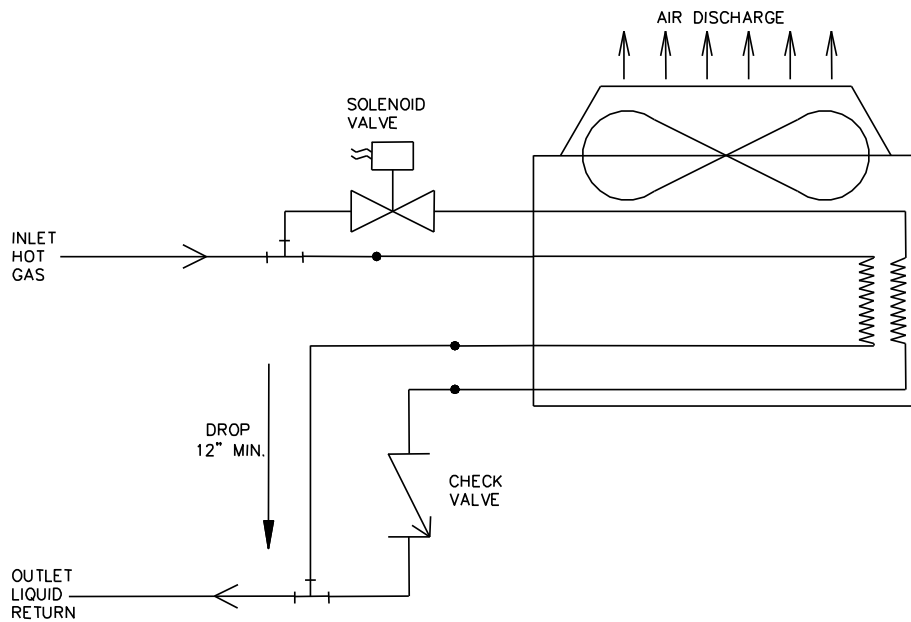

**Note:** Dash lines indicate customer supplied piping. The Check Valve in the return line (labeled “Output Liquid Return Line”) is supplied with the condenser.

**FIGURE – 9B**



**Condenser Field Piping / 50-50 Coil Split**  
**CONDENSER EQUIVALENT**  
**LINE SIZE WORKSHEET**

**Discharge Gas Line O.D.** \_\_\_\_\_

Fitting Type	Number Used	Factor	Total
Globe Valve (open)			
Angle Valve (open)			
45° Elbow			
90° Elbow			
Tee (90° turn through)			
Tee (90° straight through)			

Feet of Straight Copper Used	
Total Fitting Factor	
<b>Total Equivalent Feet</b>	

**Fitting Factors**

Copper Tube O.D. Type "L"	1/2"	5/8"	7/8"	1 1/8"	1 3/8"	1 5/8"	2 1/8"
Globe Valve (open)	14	16	22	28	36	42	57
Angle Valve (open)	7	9	12	15	18	21	28
45° Elbow	.5	1	1	1.5	2	2	2.5
90° Elbow	1	2	2	3	4	4	5
Tee (90° turn through)	3	4	5	6	8	9	12
Tee (90° straight through)	.75	1	1.5	2	2.5	2.8	3.5

**TABLE - 6**

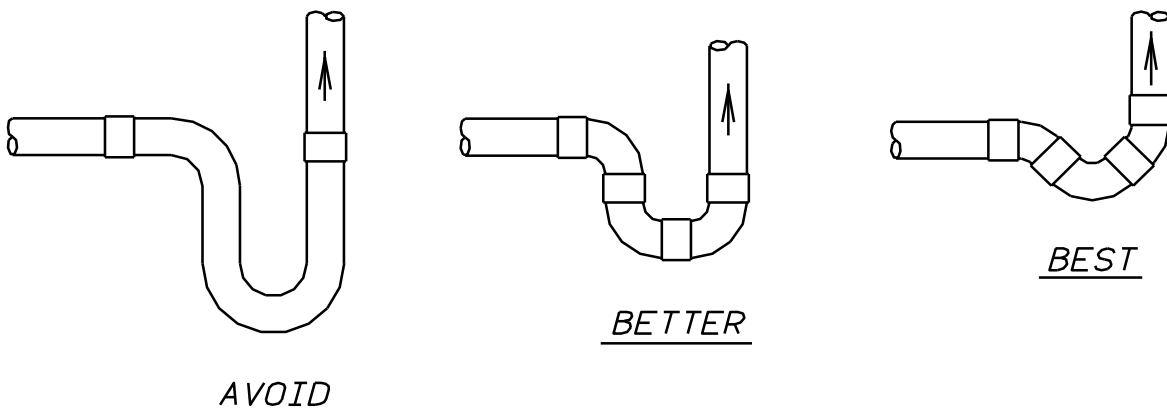

**FIGURE - 10**  
**Minimum Traps for Discharge Lines**

## Refrigerant Connections to Air-Cooled Condenser.

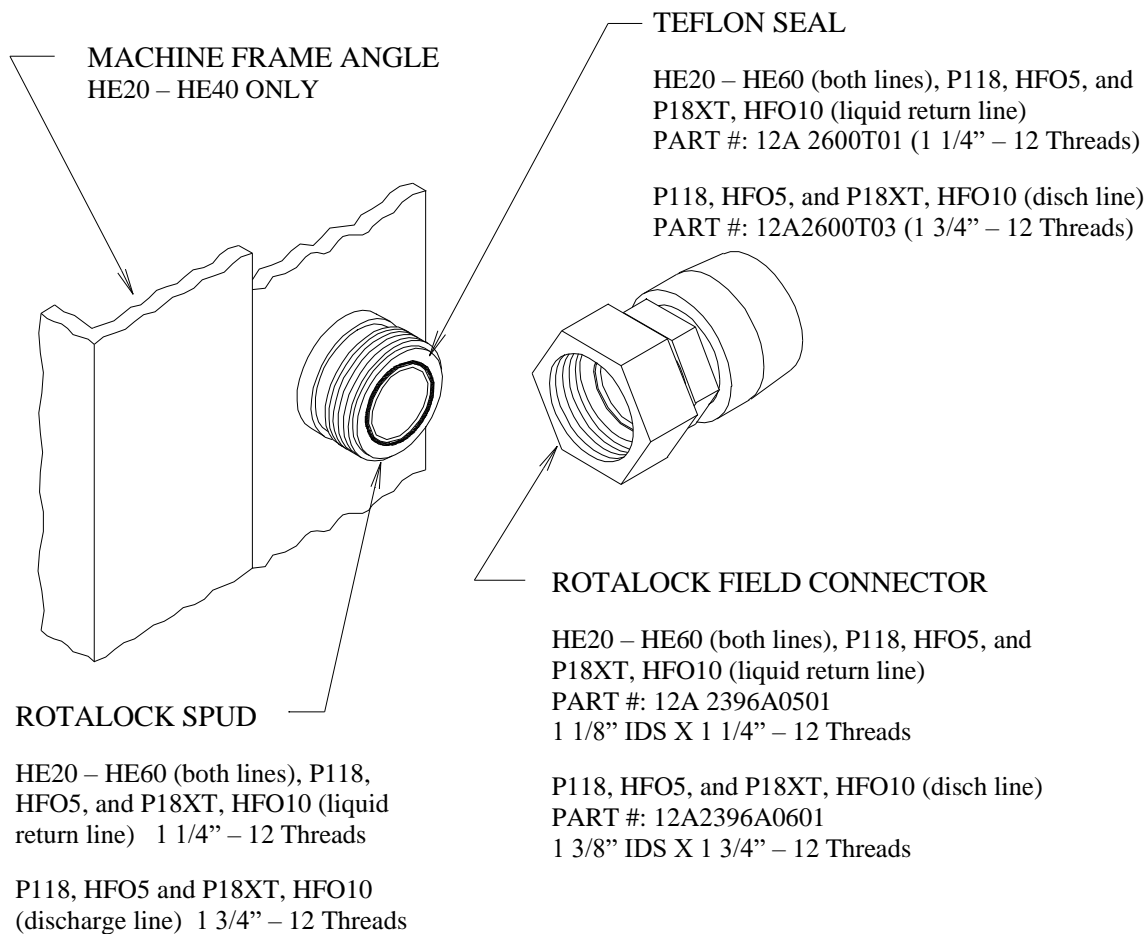

**FIGURE - 11**  
**Field Attachment, Air Cooled Condenser Refrigerant Tubing**

**FOLLOW THESE PROCEDURES TO MAKE A TIGHT JOINT**

1. Solder or braze condenser-tubing ends to the female Rotalock connectors.
2. Remove dust caps if used, making sure that component plastic seals are intact.
3. Wipe off connector and spud-threaded surfaces with a clean cloth to prevent the inclusion of dirt, or any foreign material in the system.
4. Connector coupling nut should be screwed onto Rotalock spud using the proper amount of torque (See TABLE-7).

Spud Size	Amount of Torque
1/2” – 5/8”	30-40 FT LBS
7/8”	50-60 FT LBS
1 1/8”	80-100 FT LBS

**TABLE – 7**

## Torque Ratings

### Wiring Connections to Air-Cooled Condenser.

HE Series, 200/208/230V Air-cooled condenser will be wired to the ice machine terminal block, 20, 21, 22 & 23 (see FIGURE - 12). For 400/460V machines, the air-cooled condenser will be wired to terminals 20, 21, B1, B2 & B3.

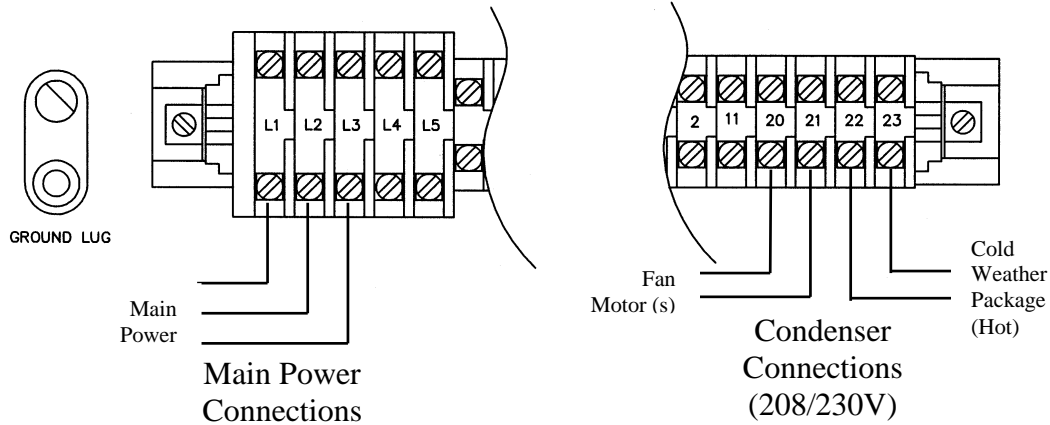

**NOTE:** For 200/208/230V machines, four wires must be run from the ice machine to the remote air-cooled condenser. For 400/460V machines with 400/460V condenser, 5 wires must be run from the ice machine to the air-cooled condenser.

**FIGURE - 12**  
**HES Series Ice Machine Terminal Block Connections**

P112, P118, HFO5, P18XT & HFO10 air-cooled condensers will be wired to the ice machines terminal block and condenser fan motor starter. Wire #'s 11 & 22 to the terminal block and B7, B8 & B9 to the motor starter.

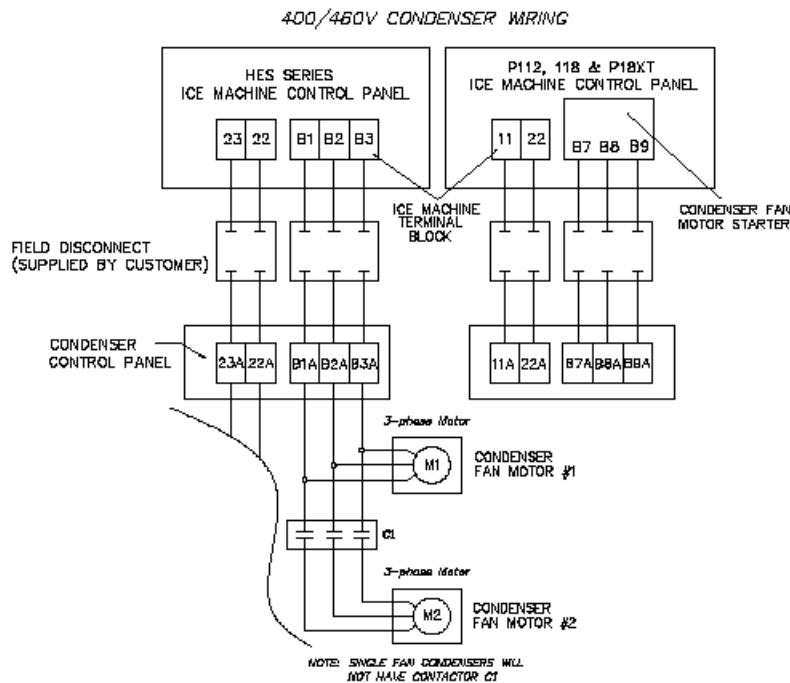

**FIGURE – 12A**  
**400/460V, 3-phase Condenser Wiring**

**Wiring Connections to Air-Cooled Condenser (Cont.)**

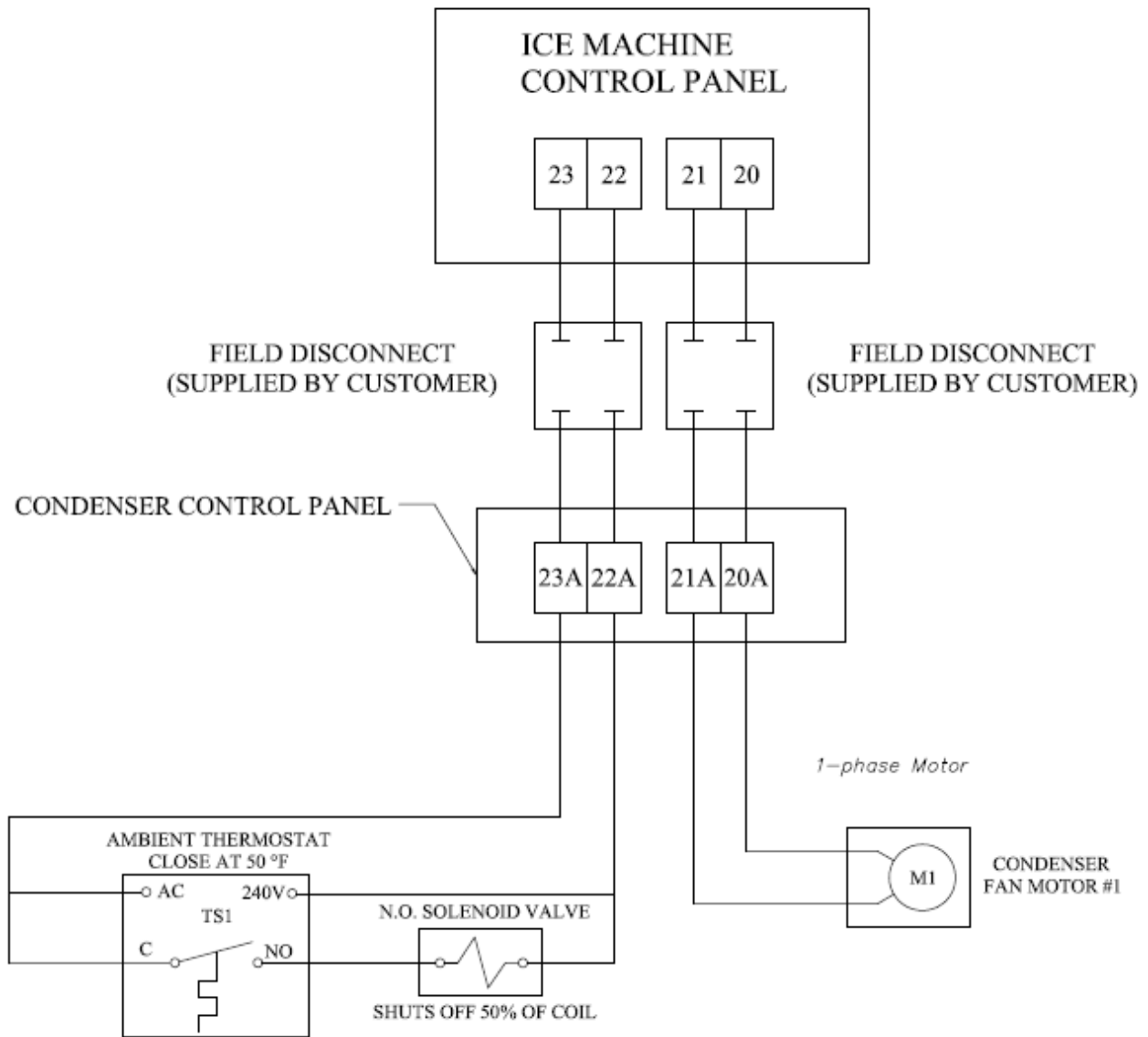

**FIGURE – 13**  
**Wiring For BOHN DVT005 with Cold Weather Valve and Single Fan,**  
**50/50 Condenser Split (200/208/230V)**

### Wiring Connections to Air-Cooled Condenser (Cont.)

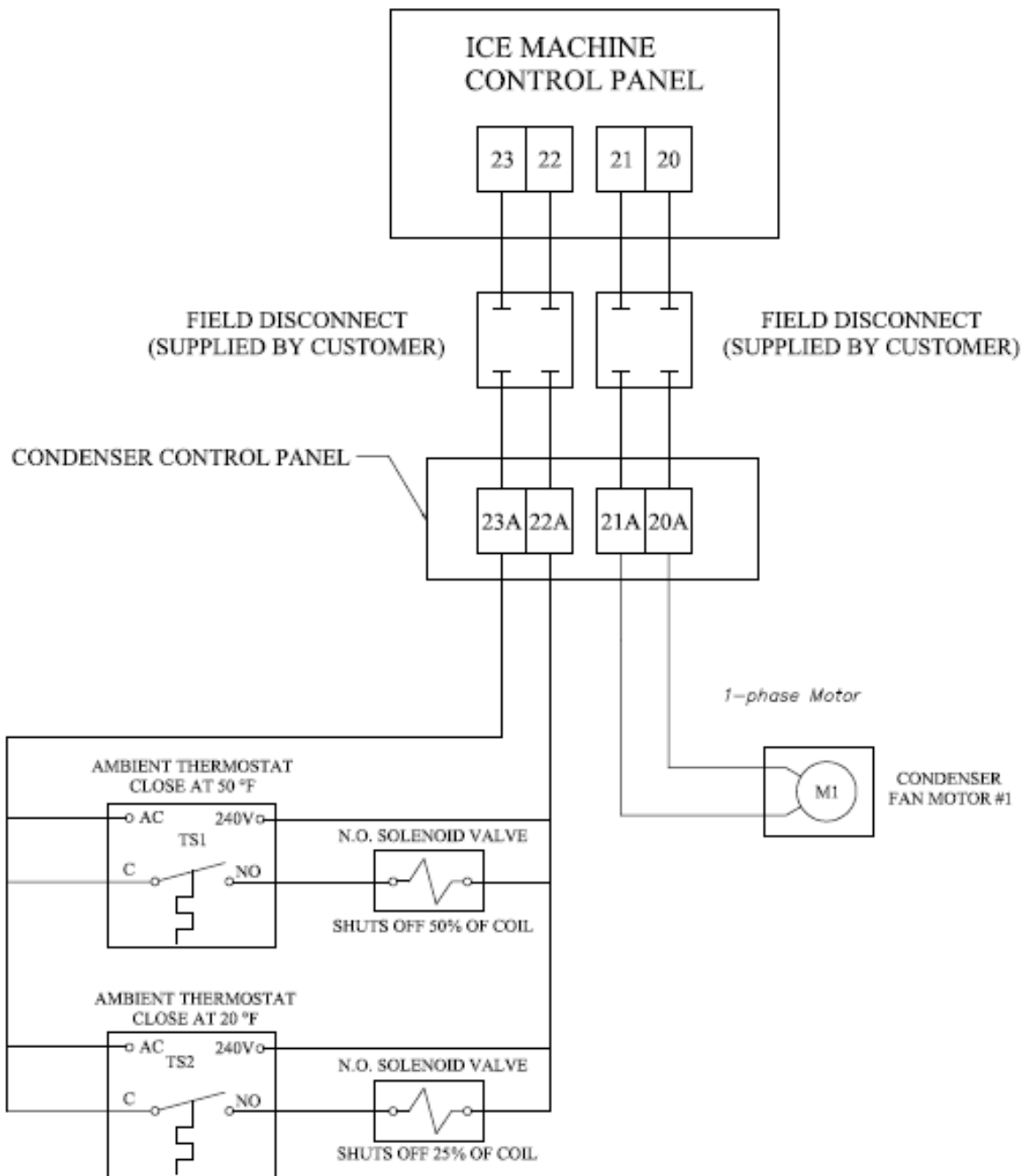

**FIGURE – 14**  
**Wiring For BOHN DVT008 with Cold Weather Valve and Single Fan,**  
**50/25/25 Condenser Split (200/208/230V)**

### Wiring Connections to Air-Cooled Condenser (Cont.)

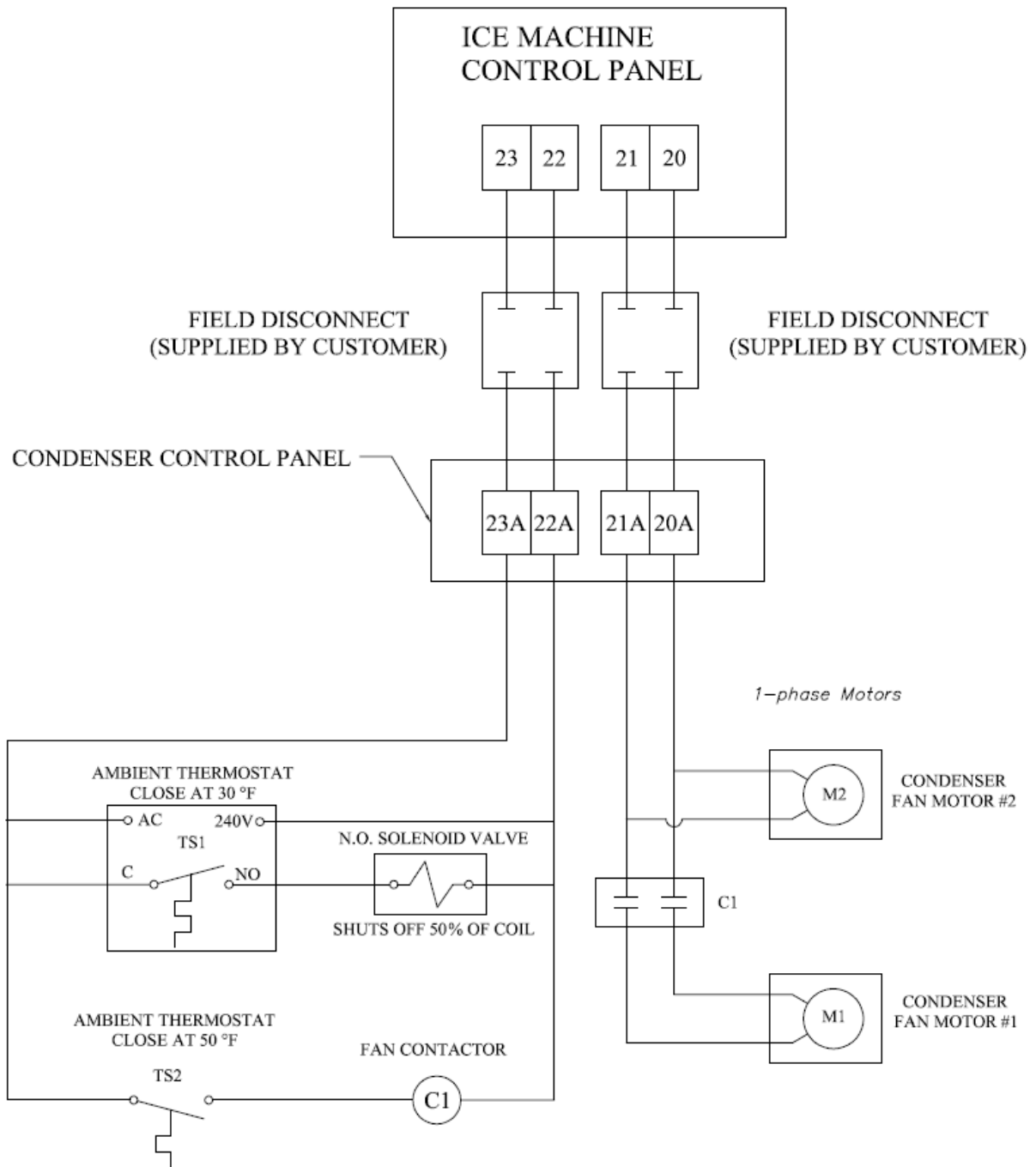

**FIGURE – 15**  
**Wiring For BOHN DVT012 /DVT016 with Cold Weather Valve and Two Fan, 50/50 Condenser Split (200/208/230V)**

### Wiring Connections to Air-Cooled Condenser (Cont.)

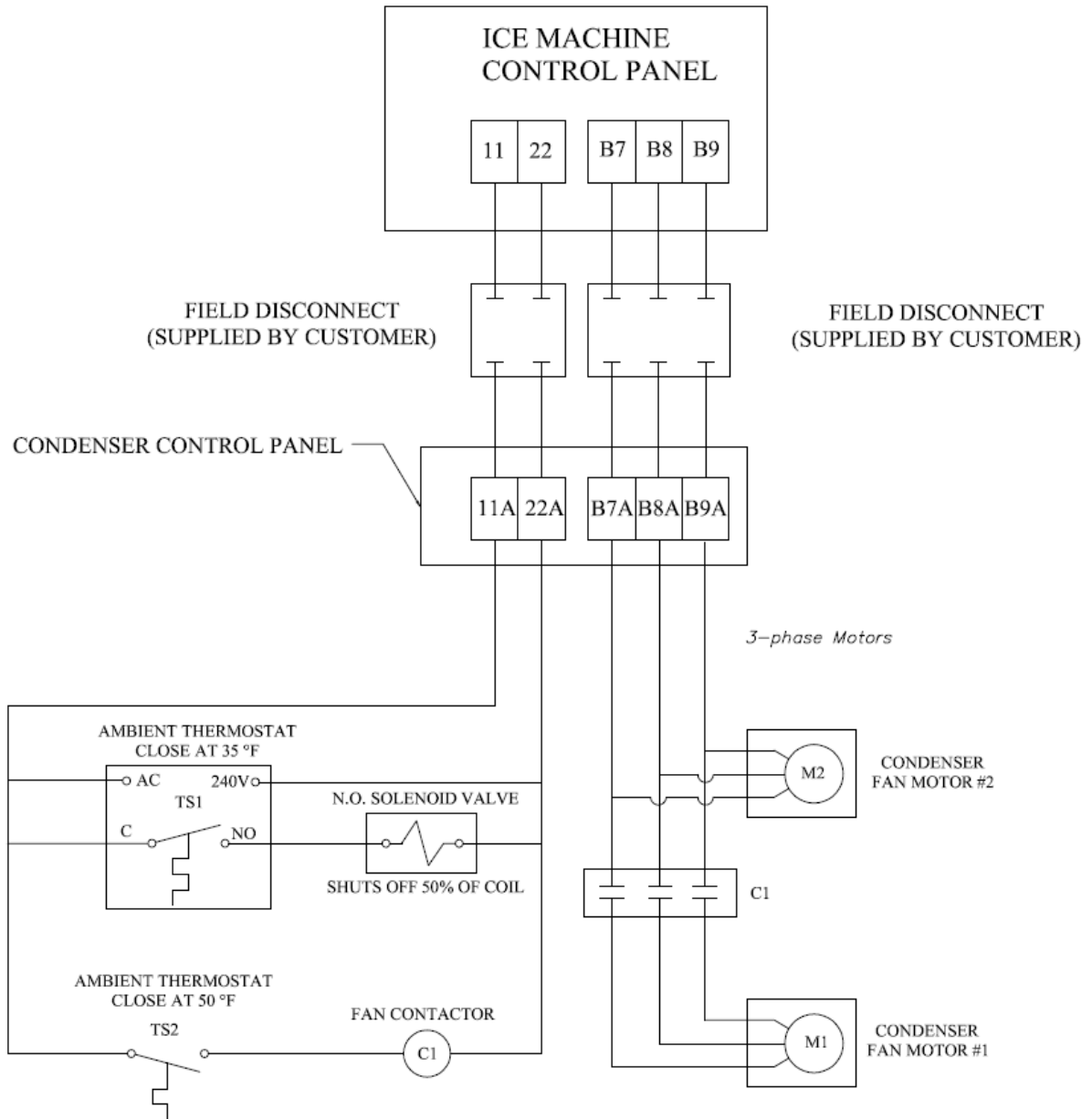

**FIGURE – 16**  
**Wiring For BOHN BNHS02A011/BNHS02A011(12) with Cold Weather Valve and Two Fan, 50/50 Condenser Split**

### Wiring Connections to Air-Cooled Condenser (Cont.)

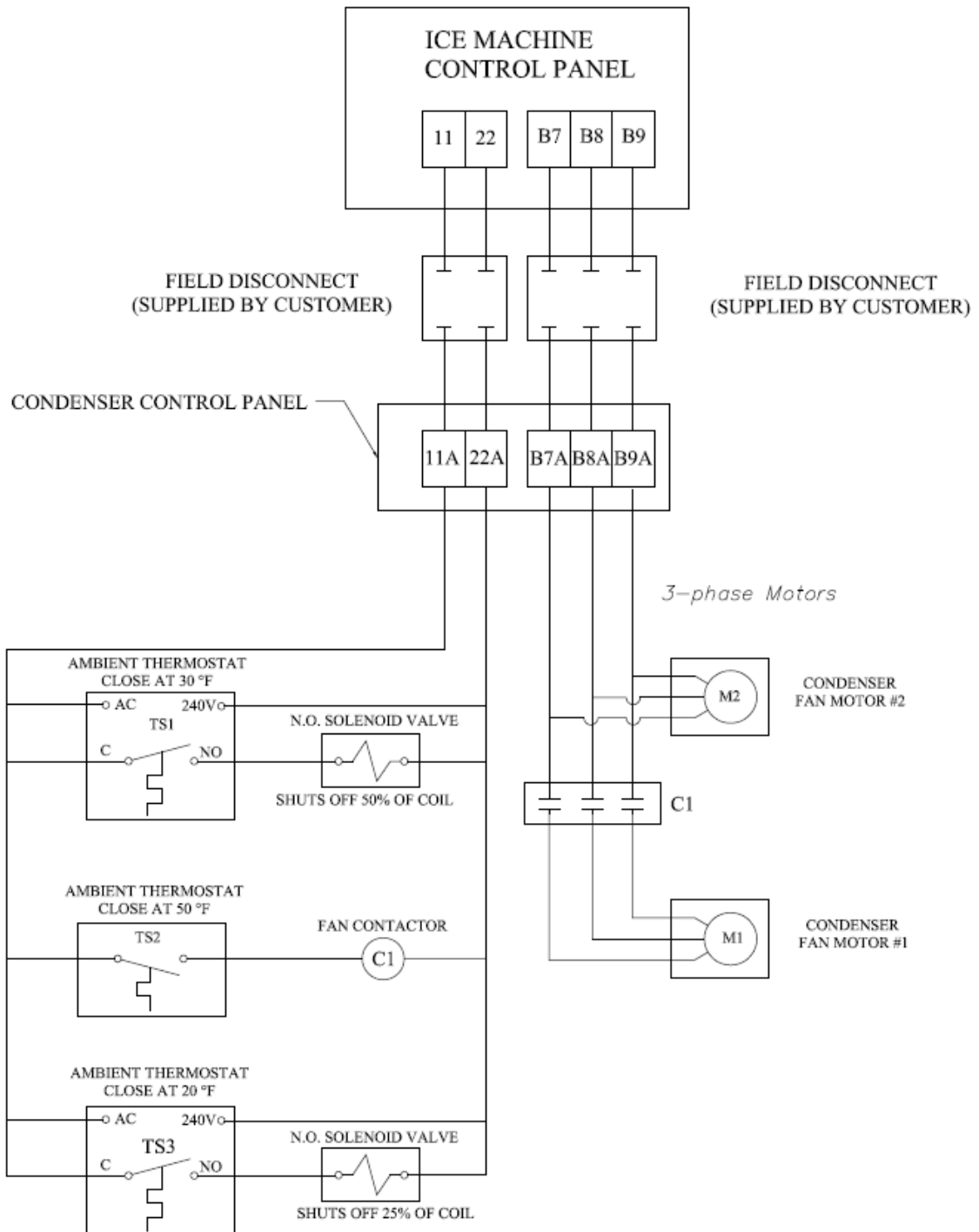

**FIGURE – 17**  
**Wiring For BOHN BNHS02A015(8)/BNHS02A015(12) with Cold Weather Valve and Two Fans, 50/25/25 Condenser Split**



## Wiring Connections to Air-Cooled Condenser (Cont.)

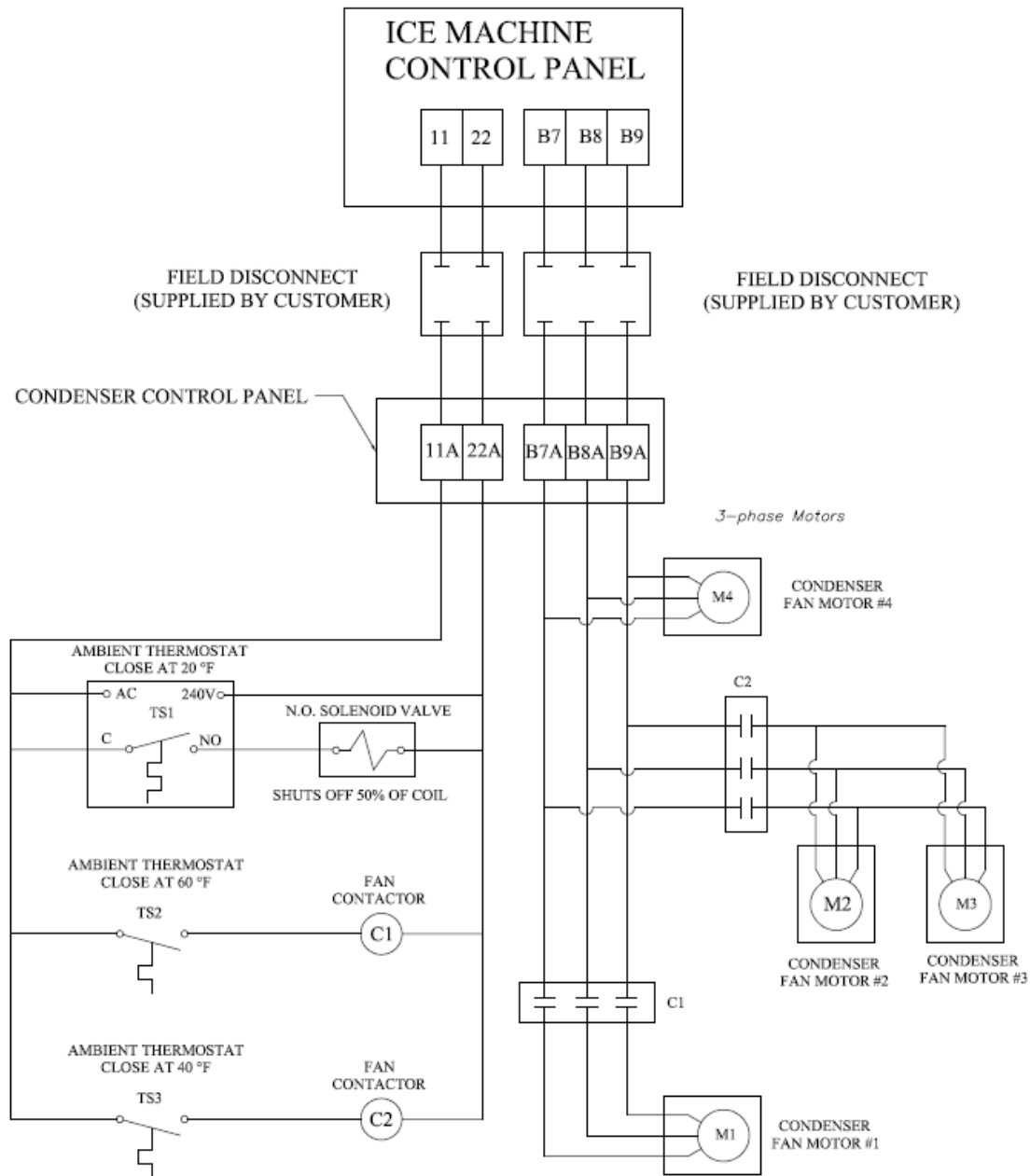

**FIGURE – 18**  
**Wiring For BOHN BNHS04A029 with Cold Weather Valve and**  
**Four Fans, 50/50 Condenser Split**

## Wiring Connections to Air-Cooled Condenser (Cont.)

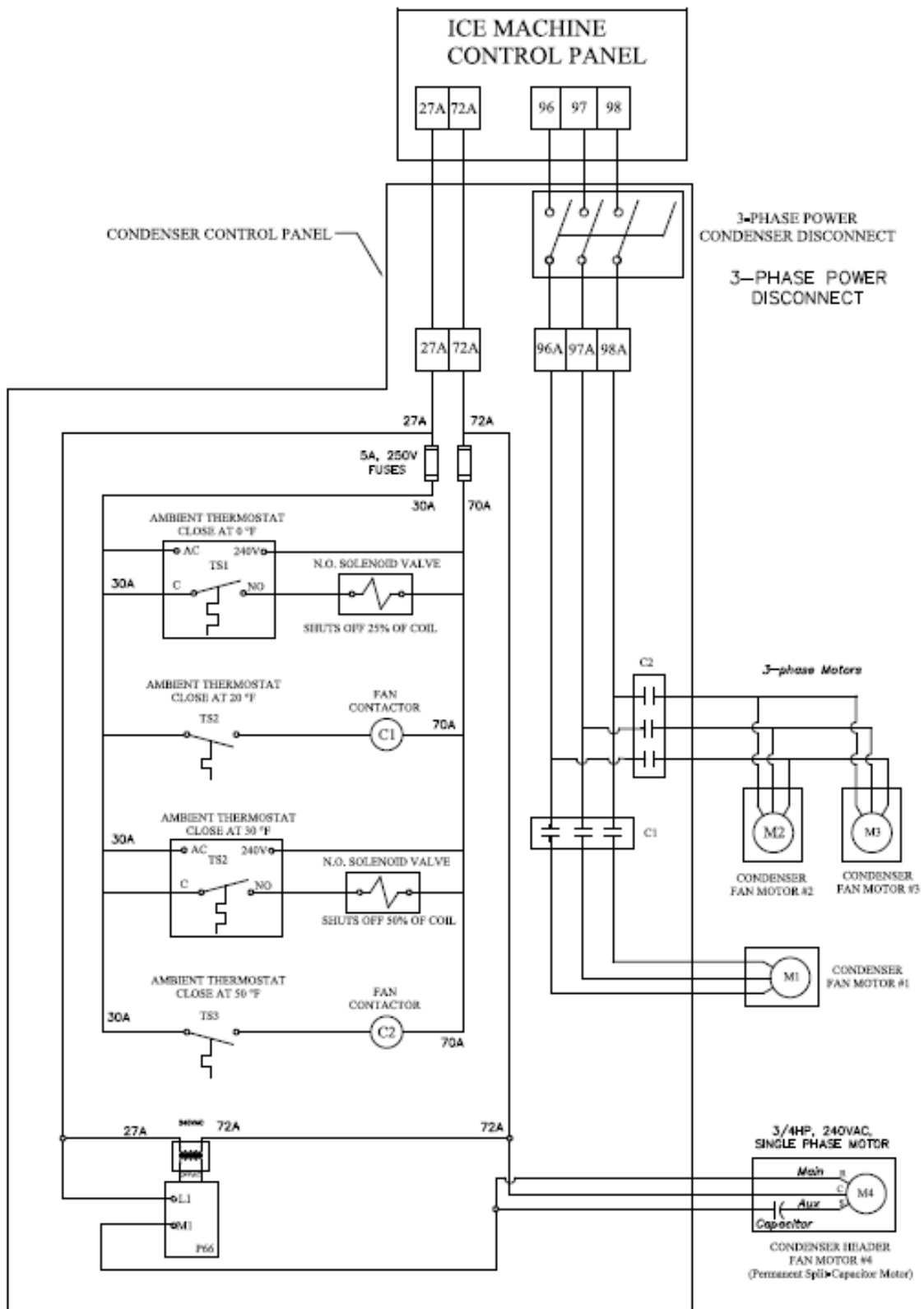
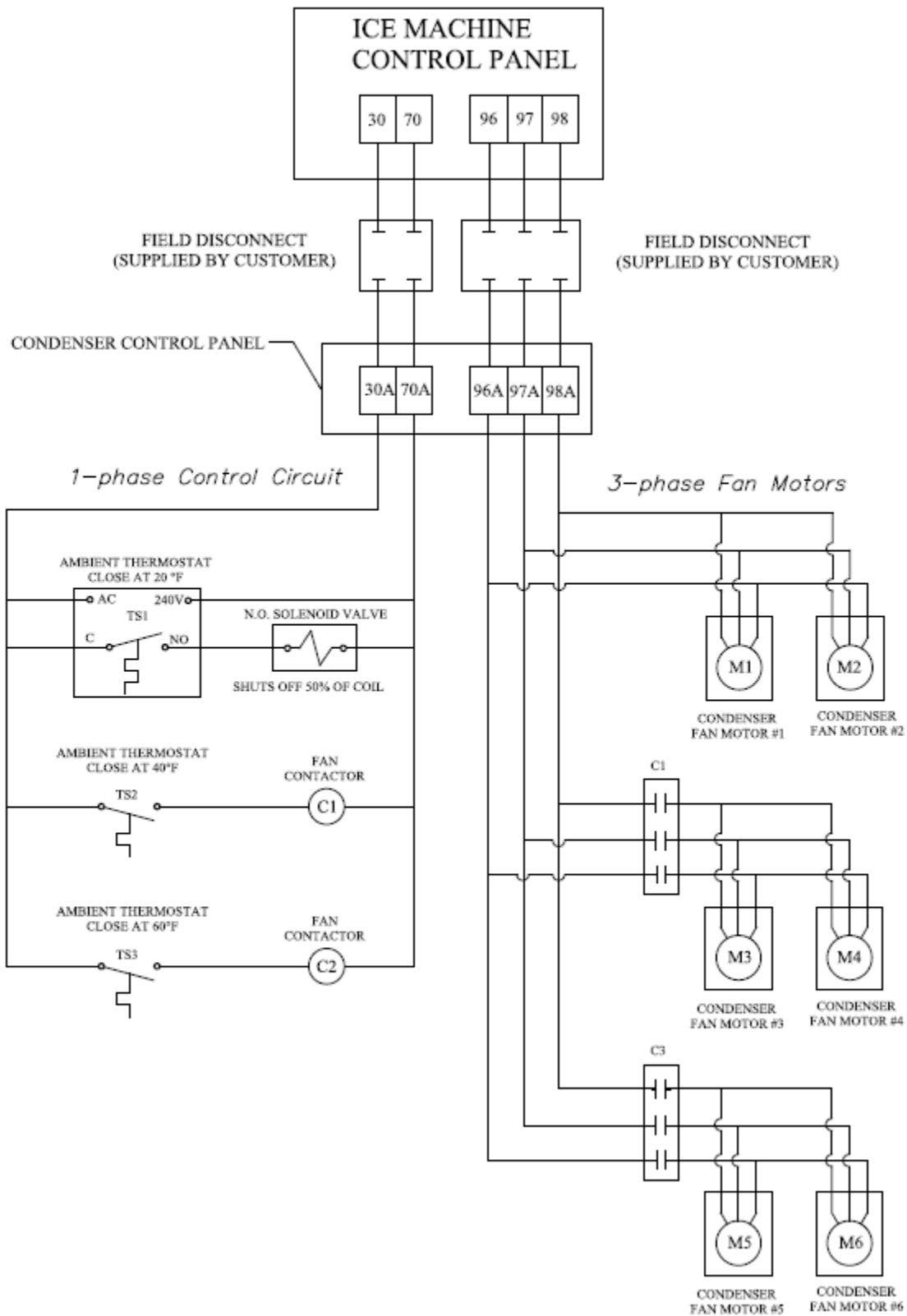

FIGURE – 18A

Wiring For BOHN BNHS04A029 with Extreme Low Ambient Kit (HFO10)  
Four Fan, 50/25/25 Condenser Split, 575V with VFD on Header Fan



**FIGURE – 18B**  
**Wiring For BOHN BNHD06A044 (Standard HFO10)**  
**Six Fan, 50/50 Condenser Split**

Condenser	Solenoid Valve				Thermostats	
	Description	Valve	Valve Rebuild Kit	Replacement Coil	Penn (Fan)	Ranco ETC (Solenoid)
DVT005	5/8" N.O. Sol.	12A4200A0503	12A4199V42	12A2105C04 (OMKC-2)	12A2117G05	N/A
DVT008	7/8" N.O. Sol.	12A4200A0704	12A4199V44			12A2117G09
DVT012/016 BNHS02A11 BNHS02A11(12)	1 1/8" N.O. Sol.	12A4200A09022	Consult factory	12A2105C43 (OMKC-1)		
		12A4200A09021	12A4199V55			
		12A4200A0902	12A4199V45	12A2105C04 (OMKC-2)		
BNHS02A15(8) BNHS02A15(12)	1 3/8" N.O. Sol.	12A4200A11022	Consult factory	12A2105C43 (OMKC-1)		
		12A4200A11021	12A4199V55			
		12A4200A1102	12A4199V45	12A2105C04 (OMKC-2)		
BNHS04A29	1 5/8" N.O. Sol.	12A4200A11041	12A4199V61	12A2105C43 (OMKC-1)		
BNHD06A044		12A4200A1104	12A4199V47	12A2105C04 (OMKC-2)		

Note: Sporlan Solenoid Valves

**TABLE – 7**  
**Bohn Cold Weather Kit Replacement Parts**

Condenser	Vogt #	Fan Motors		Fan Blades	
		Description	Vogt Part #	Description	Vogt Part #
DVT005	12A2115B03	1/3 HP – 208/230V, 1P, 50/60Hz	12A2900M0402	24" Blade	12A2115P08
DVT008	12A2115B04	1/2 HP – 208/230V, 1P, 50/60Hz	12A2900M0519	26" Blade	12A2115P09
DVT012	12A2115B05				
DVT016	12A2115B06				
BNHS02A11	12A2115B07/B08	1 1/2 HP – 208/230V/460V, 3P, 50/60Hz	12A2900M0709	30" Blade	12A2115P10
BNHS02A15	12A2115B09/B010				
BNHS04A29	12A2115B11				
BNHD06A044	12A2115B15				
BNHS04A29	12A2115B115LA				
		1 1/2 HP – 575V, 3P, 60Hz	Consult factory		

• Note: motor for header fan used with P66 speed control (12A7800V52)

**TABLE – 7A**  
**Bohn Fan Motor/Fan Blade Replacement Parts**