

***VT-Series
Ice Maker***

**Model
VT40, VT60, VT80, VT100**

FOREWORD

Vogt Ice®, LLC, strives to provide a quality product that is time-tested and will provide year of dependable service to its customers.

Skilled craftsmen have carefully assembled your Vogt® VT Series ice maker using material components and parts available from the leading vendors and producers of the highest quality refrigeration equipment in our industry. You have invested in quality equipment, and we pledge to support your needs and requirements after the sale.

This manual is provided to aid the service technician and users in the installation, operation, and maintenance of your equipment. Before attempting to install and start the machine, the installer should read and understand each section of this manual.

If, at any time, you encounter conditions that we have not addressed in this manual, we welcome you to write or call Vogt® Ice, LLC and we will give your questions our immediate attention and reply.

Vogt Ice®, LLC
1000 W. Ormsby Avenue
Suite 19
Louisville, KY 40210
(502) 635-3000
(502) 634-3024 Fax

TABLE OF CONTENTS

General Information - Section 1

History of Company	1-1
Receipt of Your Ice Machine	1-2

Installation Information - Section 2

Important Safety Notice	2-1
Machine Dimension	2-2
Machine Weights & Refrigerant Line Sizes	2-2
Ice Chute Cutout	2-3
Water Connections	2-4
Water Flow Rates / Water Tank Capacity	2-4
Electrical Connections	2-5
Air Cooled Condenser Installation	2-7
Air Cooled Condenser Wiring	2-9
Storing Ice – Bin Thermostat Mounting	2-12

Model Specifications and Wiring Diagrams - Section 3

Model Specifications	3-1
Model Number Structure	3-2

Initial Startup - Section 4

Startup Procedure	4-1
Circuit Breakers & Lowside Control Panel Front	4-2
Service Valve Locations	4-3
Adding Refrigerant	4-4
Suction Line Access Fitting	4-4
Removing Refrigerant	4-5

Electrical Controls - Section 5

Explanation of Controls	5-1
Startup & Standby Mode	5-1
Freeze Mode	5-1
PLC & Freezer Timer	5-1
Harvest Mode	5-2
Harvest Hold Pressure Switch (Increasing Harvest)	5-2
Clean Mode	5-2
PLC Input / Output Table	5-3
Fault Mode & Faults Designations	5-3
Electrical Schematic	5-4
Lowside Electrical Schematic	5-5
Lowside Control Panel Layout	5-6
Condensing Unit Electrical Schematic	5-7
Condensing Unit Control Panel Layout	5-8

Maintenance - Section 6

Preventive Maintenance	6-1
Preventive Maintenance Program	6-2
Air Cooled Condenser Cleaning.....	6-3
Compressor Oil	6-3
Chopper Gear Reducer Oil	6-4
Water Distributor	6-4

Troubleshooting - Section 7

Machine Fault Light	7-1
Control Power Light	7-1
PLC	7-2
Damaged Bin Control Sensor	7-2
Machine Inoperative.....	7-3
Machine "Freeze-Up"	7-4
Additional Troubleshooting	7-5

Service Operations - Section 8

Principle Of Operation	8-1
Pressure Switches	8-2
Bin Control (Electronic Temperature Control)	8-3
PLC (Programmable Logic Controller)	8-4
Compressor.....	8-5
TXV & Solenoid Valve.....	8-6
Adjusting TXV	8-7
Inlet Pressure Regulator	8-7
Water Tank Parts	8-8
Chopper Assembly	8-9
Evaporator Housing Covers	8-10
Freeze Cycle Piping Schematic (No Hot Gas Loop)	8-11
Harvest Cycle Piping Schematic (No Hot Gas Loop)	8-12
Freeze Cycle Piping Schematic (With Hot Gas Loop)	8-13
Harvest Cycle Piping Schematic (With Hot Gas Loop)	8-14
Freeze Cycle Piping Schematic (With Suction Stop Valve)	8-15
Harvest Cycle Piping Schematic (With Suction Stop Valve)	8-16
Replacement Parts List	8-17

Options and Accessories - Section 9

Voltage Monitor (Wagner Model DTP-3)	9-1
Remote Switch (Includes Ice/Off/Clean selector switch, start button & fault light)	9-2

1. General Information

HISTORY OF COMPANY

Henry Vogt Machine Co. was founded as a small machine shop in Louisville, Kentucky in 1880. In 1938, Vogt built the first Tube-Ice® machine and revolutionized the ice-making industry. Our first “sized-ice” machine quickly replaced the old can-ice plants, which required much hard labor and large amounts of floor space for freezing, cutting, and crushing ice by hand.

Today, Vogt Ice®, LLC carries on the tradition as one of the world’s leading producers of ice-making equipment.

Preview Vogt® VT Series ice machines are built with the skill in engineering and fabrication that we have learned in over a century of ice machine manufacturing.

Furnished with your machine is the “Certificate of Test”--the report of operating data that is a record of the unit’s satisfactory operation on our factory test floor.

This manual is designed to assist you in the installation, start-up, and maintenance of your unit. Your VT® machine will give you many years of service when you install it, maintain it, and service it properly.

Please read your manual carefully before attempting installation, operation, or servicing of this piece of equipment.

If you have additional questions, please call your distributor. Also, feel free to phone the factory direct at **(502) 635-3000** or **1-800-853-8648**.

Receipt Of Your Ice Machine

! CAUTION !
Only service personnel experienced in refrigeration and qualified to work on high amperage electrical equipment should be allowed to install or service this VT ice machine.
Eye protection should be worn by all personnel working on or around the VT machine.
It is very important that you are familiar with and adhere to all local, state, and federal, etc. ordinances and laws regarding the handling, storing, and use of R404A.
! CAUTION !

Inspection. As soon as you receive your machine, inspect it for any damage. If damage is suspected, note it on the shipper's papers (i.e., the trucker's Bill of Lading). **Immediately** make a separate written request for inspection by the freight line's agent. Any repair work or alteration to the machine without the permission of the Vogt Ice can void the machine's warranty. You should also notify your Vogt distributor or the factory.

Safety Tags and Labels. Be sure to read and adhere to all special tags and labels attached to valves or applied to various areas of the machine. They provide important information necessary for safe and efficient operation of your equipment.

2. Installation Information

Important Safety Notice. This information is intended for use by individuals possessing adequate backgrounds of electrical, refrigeration and mechanical experience. Any attempt to repair major equipment may result in personal injury and property damage. The manufacturer or seller cannot be responsible for the interpretation of this information, nor can it assume any liability in connection with its use.

Special Precautions To Be Observed When Charging Refrigeration Systems. Only technically-qualified persons, experienced and knowledgeable in the handling of refrigerant and operation of refrigeration systems, should perform the operations described in this manual. All local, federal, and EPA regulations must be strictly adhered to when handling refrigerants.

If a refrigeration system is being charged from refrigerant cylinders, disconnect each cylinder when empty or when the system is fully charged. A gage should be installed in the charging line to indicate refrigerant cylinder pressure. The cylinder may be considered empty of liquid R404A refrigerant when the gauge pressure is 25 pounds or less, and there is no frost on the cylinder. Close the refrigerant charging valve and cylinder valve before disconnecting the cylinder. Loosen the union in the refrigerant charging line--carefully to avoid unnecessary and illegal release of refrigerant into the atmosphere.

! CAUTION !

Immediately close system charging valve at commencement of defrost or thawing cycle if refrigerant cylinder is connected. Never leave a refrigerant cylinder connected to system except during charging operation. Failure to observe either of these precautions can result in transferring refrigerant from the system to the refrigerant cylinder, over-filling it, and possibly causing the cylinder to rupture because of pressure from expansion of the liquid refrigerant brought on by an increase in temperature.

! CAUTION !

Always store cylinders containing refrigerant in a cool place. They should never be exposed to temperatures higher than 110°F and should be stored in a manner to prevent abnormal mechanical shocks. Also, transferring refrigerant from a refrigeration system into a cylinder can be very dangerous and is not recommended.

! CAUTION !

It is not recommended that refrigerant be transferred from a refrigeration system directly into a cylinder. If such a transfer is made, the refrigerant cylinder must be an approved, CLEAN cylinder--free of any contaminants or foreign materials--and must be connected to an approved recovery mechanism with a safety shutoff sensor to assure contents do not exceed net weight specified by cylinder manufacturer or any applicable code requirements.

! CAUTION !

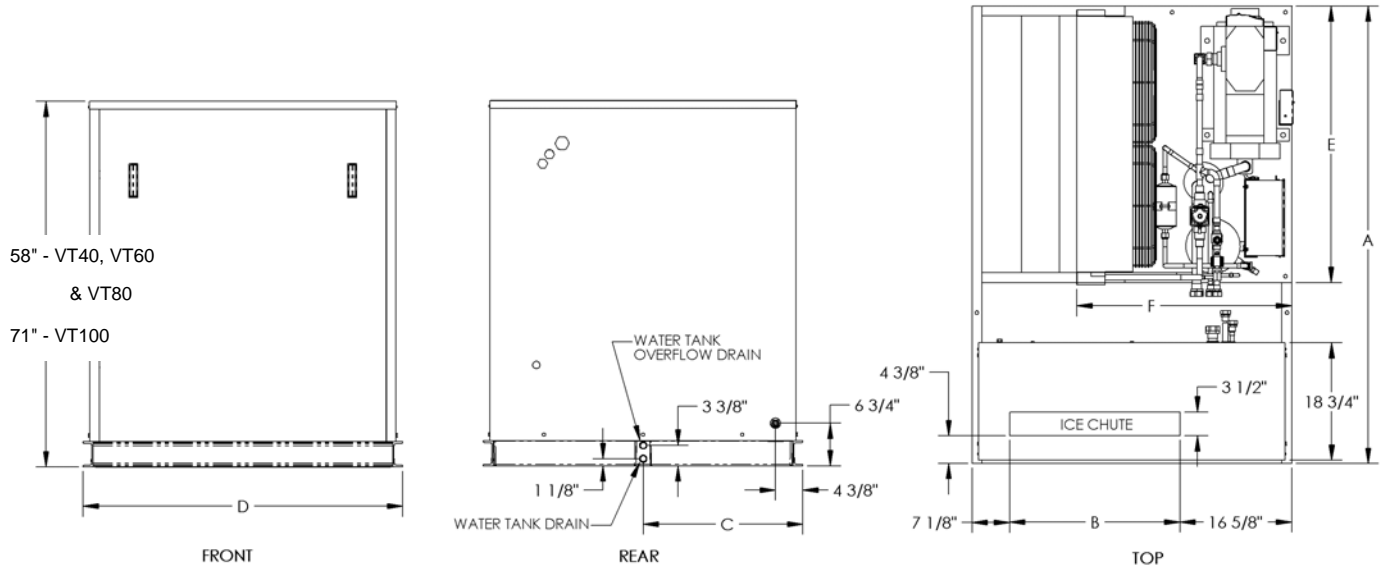

FIGURE 2-1
Ice Machine Dimensions

Unit	"A"	"B"	"C"	"D"	"E"	"F"
VT40	72 5/8"	27"	24 3/8"	50 3/4"	44"	34"
VT60	89"	39 1/2"	30 1/2"	63 1/4"	57.5"	68"
VT80 & VT100	44 7/8"				N/A	N/A

TABLE 2-1
Ice Machine Dimensions

Remote Weights			Skid Mounted Weights	
Model	Lowside	Condensing Unit	Model	Skid Mounted
VT40	520 lbs.	975 lbs.	VT-40	1,525 lbs.
VT60	650 lbs.	1330 lbs.	VT-60	2290 lbs.
VT80	1,475 lbs.	375 lbs. (condenser)	VT-80	-----
VT100	1,850 lbs.	400 lbs. (condenser)	VT-100	-----

TABLE 2-2
Weight Of Machines

Model	Suction Line	Hot Gas Line	Liquid Line	Remote Condenser	
				Discharge	Liquid Return
VT40	1 3/8 OD	7/8 OD	5/8 OD	N/A	N/A
VT60		1 1/8 OD	7/8 OD	1 1/8 OD	7/8 OD
VT80	1 5/8 OD				
VT100	1 3/8 OD				

Note: Split systems will be supplied with Rota-lock adapters to connect the highside to the lowside

TABLE 2-3
Refrigerant Line Sizes

Machine Clearances: A minimum three (3) feet of clearance is recommended around entire ice machine. This will provide sufficient area for service and air flow.

Evaporator Installation: Mount evaporator section (lowside) on storage area capable of sustaining its weight and secure by thru bolting.

Note: Ambient at the lowside should remain between 50°F–105°F. Makeup water temperature should not drop below 40°F. Machine may experience problems if operated outside of these ranges.

Piping Installation: Use ACR refrigeration tubing and nitrogen purge during brazing to prevent formation of copper oxide. For piping runs exceeding 25', consult a reliable piping manual (Copeland, Heatcraft, or Vilter) for proper pipe sizing. Heat sink all ball valves and remove Schrader valve core prior to brazing. Pressure test piping for leaks. Evacuate lines to 500 microns prior to starting machine.

Chute Location: Using drawing and table below, determine ice machine location so that it is centered on bin. Place ice machine on storage unit and bolt in place. **Machine must be level front to back and side to side for proper operation.**

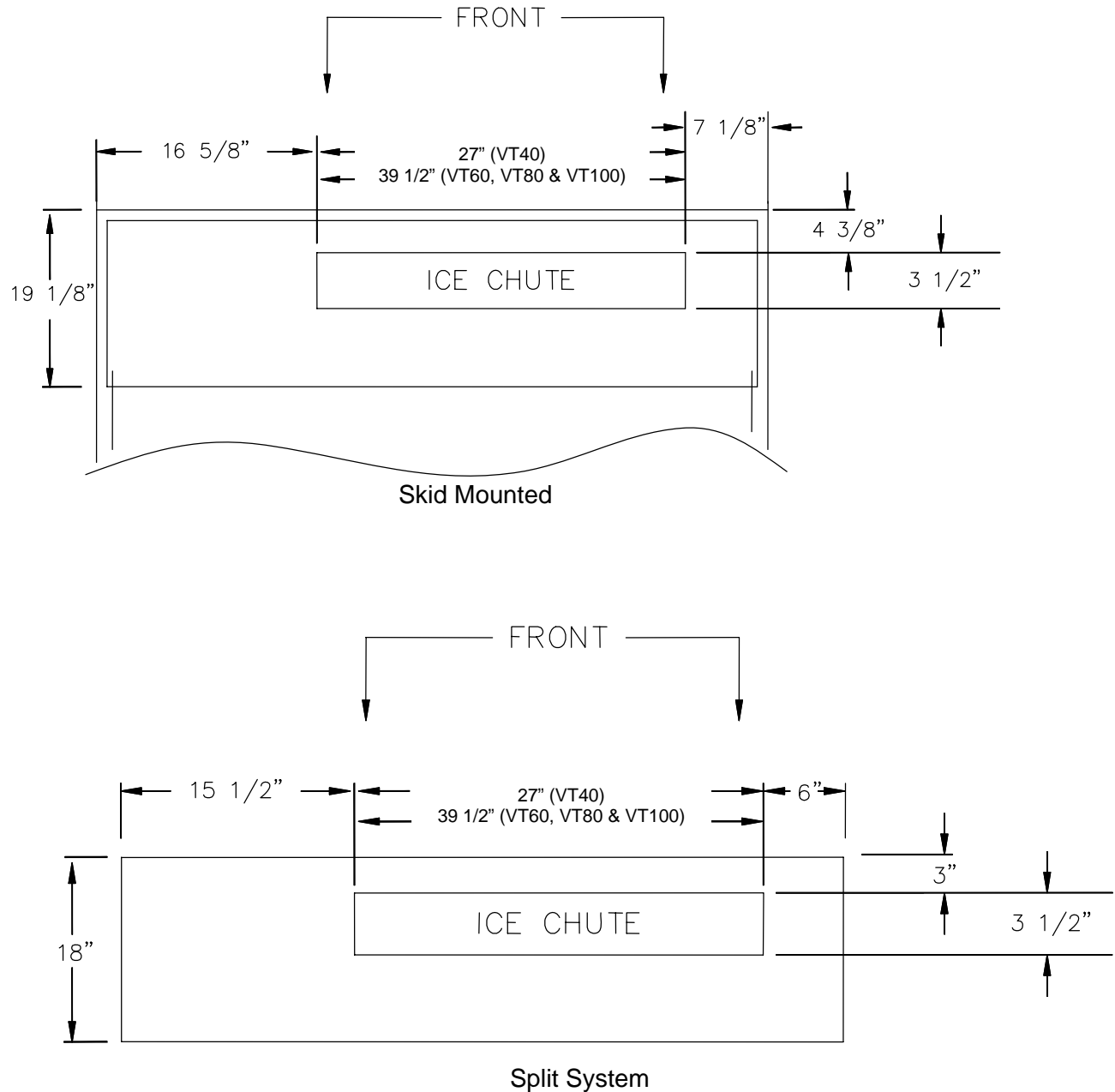
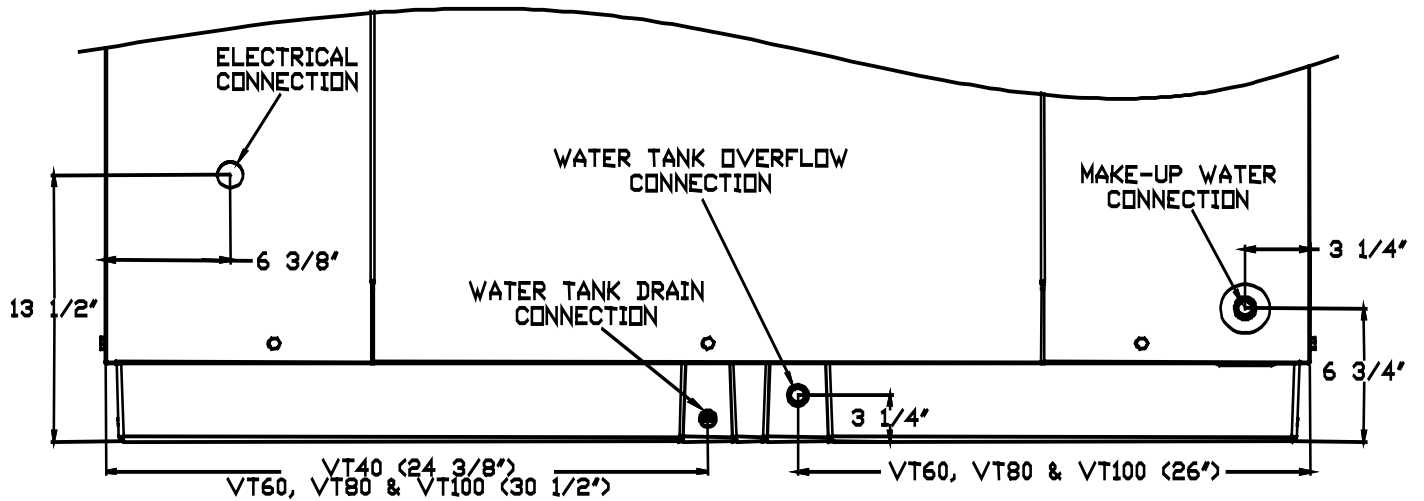

FIGURE 2-2
Ice Chute Cutout Location



NOTE: VT40 OVERFLOW CONNECTION DIRECTLY ABOVE TANK DRAIN CONNECTION

Makeup, water tank drain and water tank overflow are 1/2" FPT connections

FIGURE 2-3
VT Lowside Water and Electrical Connections – Rear View

Makeup Water Flow	VT40	VT60	VT80	VT100
Usage - Gallons /100 lbs of Ice	12	12	12	12
Flow rate – Gallons / minute	0.38	0.54	0.67	0.80
Flow rate – Gallons / hour	22.5	32.5	40.0	48.0
Water Tank Capacity – Gallons	6	7		

Note: Water usage and flow rates base on 70°F water with no blowdown

TABLE 2-4
MakeUp Water Requirements / Flow Rates

Wiring And Electrical Connection.

! WARNING !
Only service personnel experienced in refrigeration and qualified to work with high voltage electrical equipment should be allowed to install or work on the Vogt® VT Series Ice machine.
! WARNING !

Main Power: Power for the entire ice machine will be supplied at the condensing unit. Refer to the table below to properly size wiring connections. **A fused disconnect must be provided** near the condensing unit of the ice machine. Connect 3 phase power to compressor contractor L1, L2, L3 for operation of the VT ice machine and its controls. If one leg of the 3 phase power is higher or lower (“Wild”), it should be connected to terminal #L2. Connect the “Ground” wire to the “Ground” terminal provided.

Electrical Data	VT40	VT60	VT80		VT100	
Volts/ Phase/ Hertz	208/230-3-60	208/230-3-60	208/230-3-60	460-3-60	208/230-3-60	460-3-60
Total F.L.A. Rating	46.1	56.4	67.2	32	80.6	38.7
Minimum Circuit Ampacity	54.0	66.9	80.4	38.6	97.1	47
Maximum Fuse	85	110	135	65	165	80

**TABLE 2-5
Electrical Requirements**

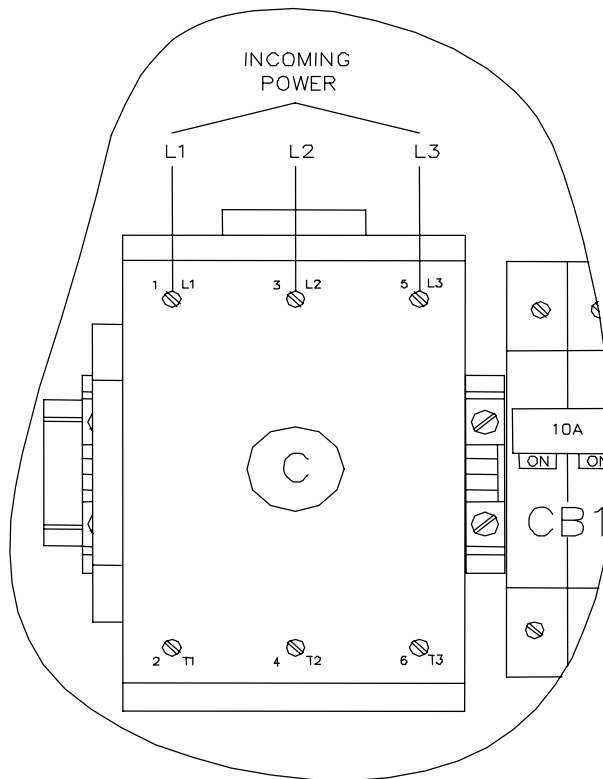

**FIGURE 2-4
Main Power Connection**

2-6

Installation Instructions

Air Cooled Condenser Wiring: Run two #14 AWG wires from the terminals T4 and T5 on the condensing unit control panel terminal block to the air cooled condenser control panel.

Note: 400/460V VT-80 & VT100's run 3 #14 AWG wires from terminals L6, L7 & L8 to air cooled condenser.

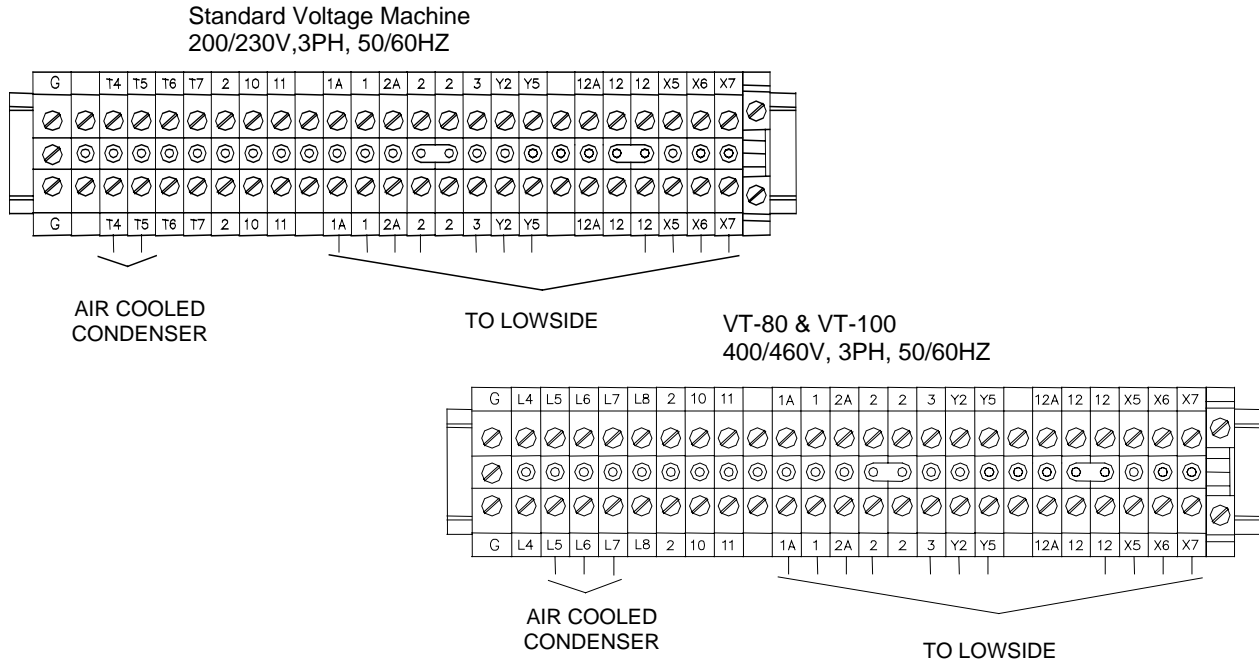

FIGURE 2-5

Condensing Unit Terminal Blocks

Lowside Electrical Connections: Run 11 #14 AWG or larger wires run from the Lowside control panel terminal block to the condensing unit (highside) control panel terminal block.

Number of wires	Wire Size (AWG)	Wire #
5	16 (Red)	1, 2, 3, Y2, Y5
4	16 (Blue)	X5, X6, X7, 12
2	14 (Black)	1A, 2A
1	14 (Green)	GND

TABLE 2-6

Lowside to Highside Wire

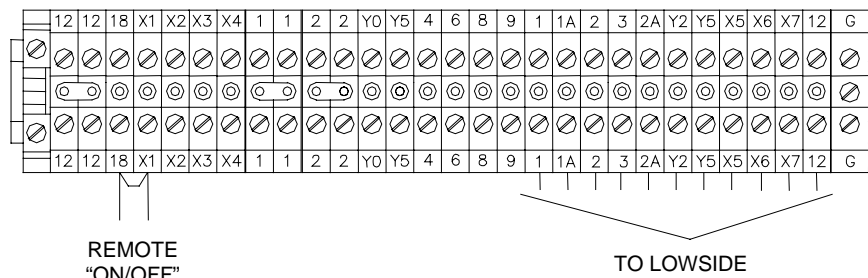

FIGURE 2-6

Lowside Unit Terminal Block

Note: Machine is supplied with a remote "on/off" connection on the lowside terminal block. If a remote "On/Off" switch is used, remove jumper between #18 & #X1 and connect switch to these terminals.

Power is supplied to the lowside through circuit breaker (CB1) located in the condensing unit control panel. See diagram below.

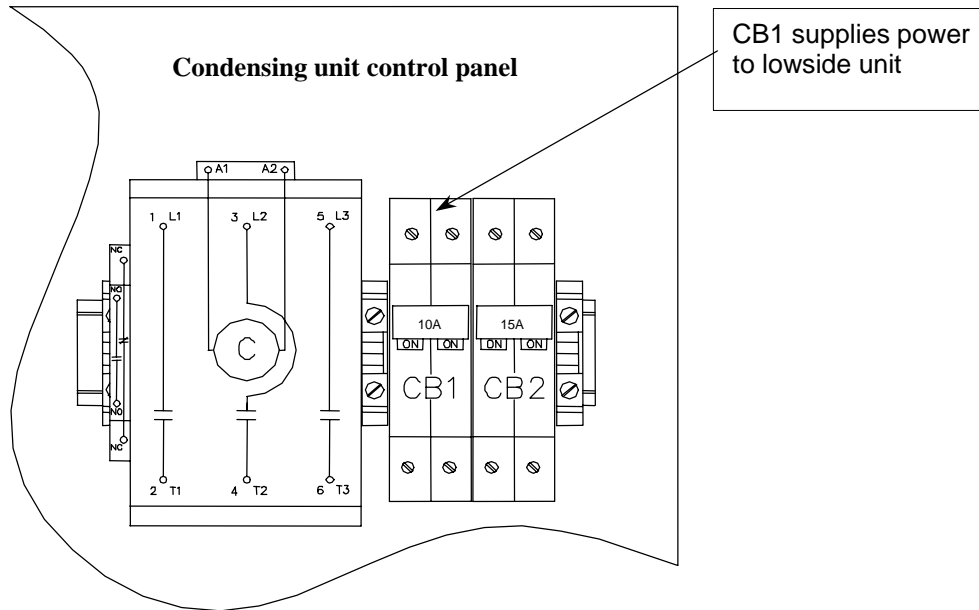

FIGURE 2-7
Condensing Unit Circuit Breakers (200/230V)

Air Cooled Condenser Installation (VT80 & VT100): Ice making systems with remote condensers are trapped internally. A trap leaving the compressor is not necessary. On vertical runs a short radius “P” trap should be installed every 15’ to 20’ of vertical rise to facilitate oil flow. Horizontal runs should be sloped in direction of refrigerant flow 1” for every 20’ of run. The condenser should be securely mounted in a place capable of sustaining its weight.

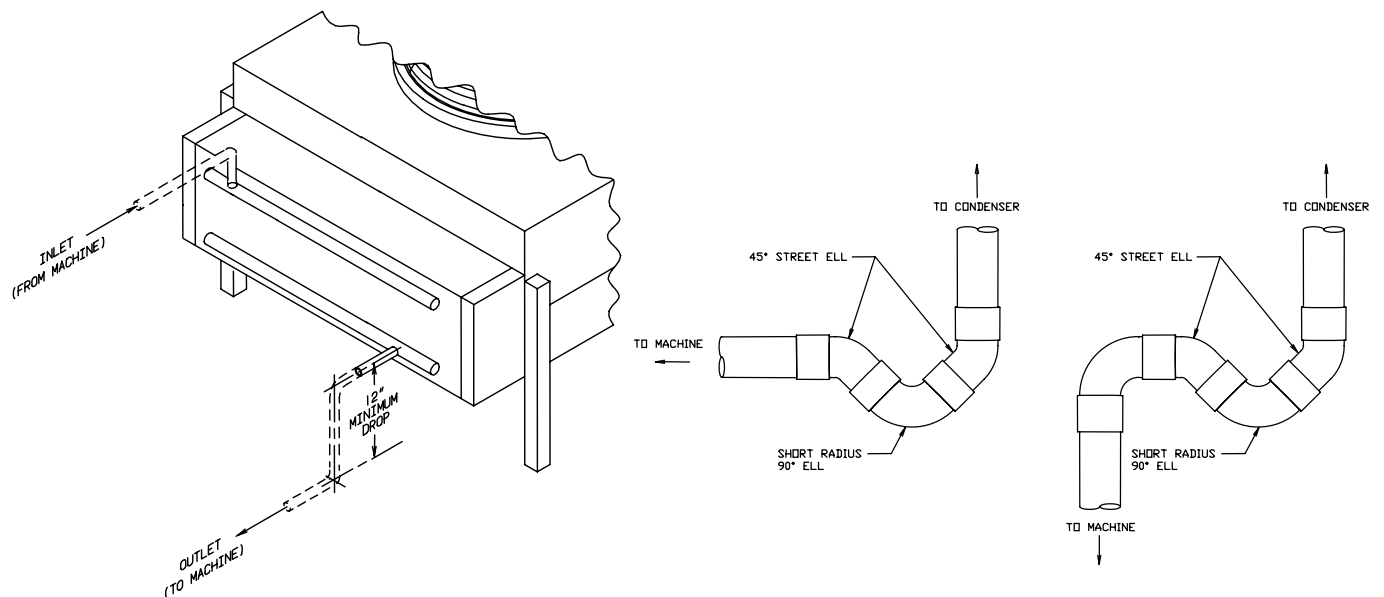
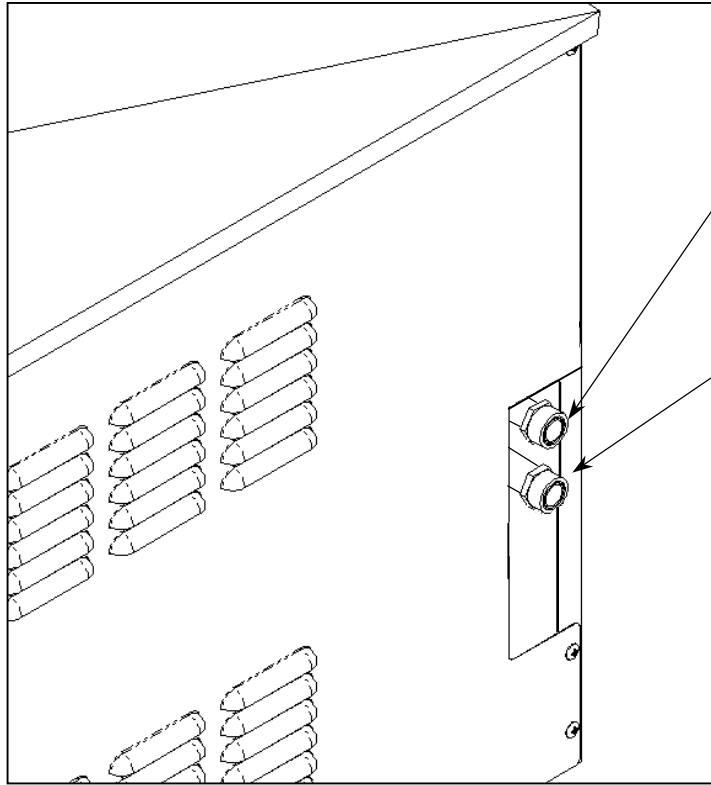

FIGURE 2-8
Condenser Piping (VT80 & VT100) and Recommended Traps

Must solder with 45% silver solder



Liquid return from Air Cooled Condenser (7/8" line)

Discharge gas to Air Cooled Condenser
VT80 - 1 1/8"
VT100 - 1 3/8"

Female Rota-lock Adapters:
 12A2396A0701 – for 1 1/4"-12 F x 7/8" Sweat (Return Line from condenser)
 12A2396A0601 – for 1 3/4"-12 F x 1 3/8" Sweat (Discharge to condenser)

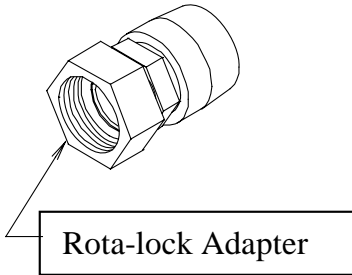

Rota-lock Adapter

Note: Rota-lock adapters supplied with machine

Teflon Seal
 12A2600T01 (for 1 1/4"-12 thread fitting)
 12A2600T03 (for 1 3/4"-12 thread fitting)

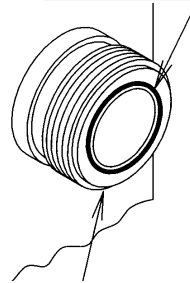

Note: Rota-lock male adapter on ice machine

FIGURE 2-10
VT80 & VT100 Condenser Refrigerant Line Connections

Air Cooled Condenser: The air cooled condenser will be wired to the condensing unit control panel. Run two #14 AWG wires and a ground wire from the condensing unit control panel to the Air Cooled condenser control panel.

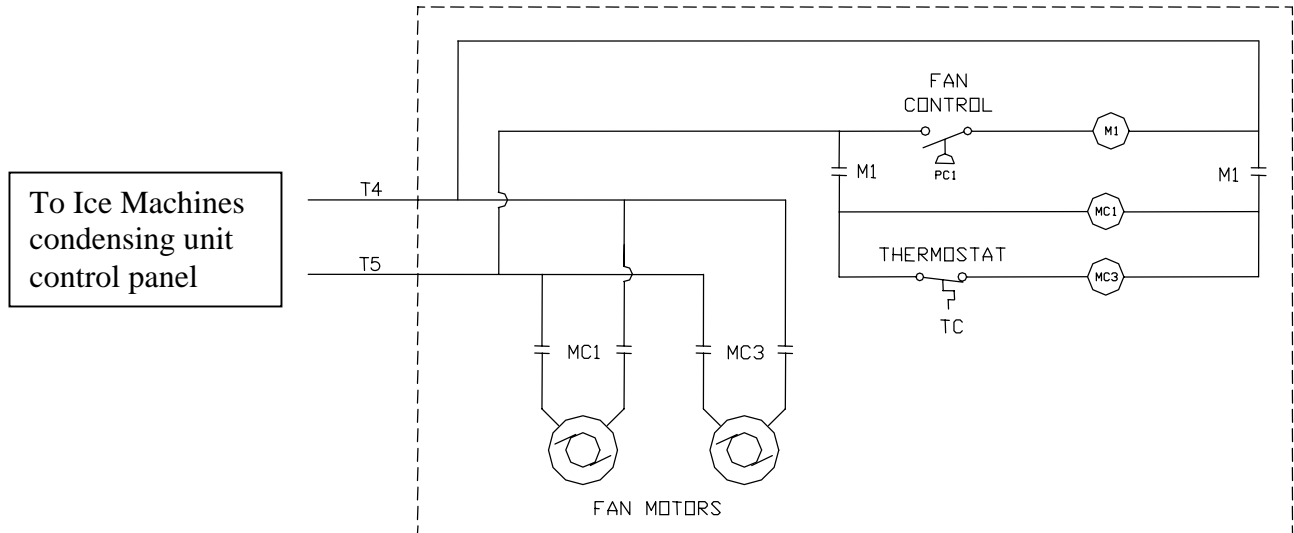

208/230V

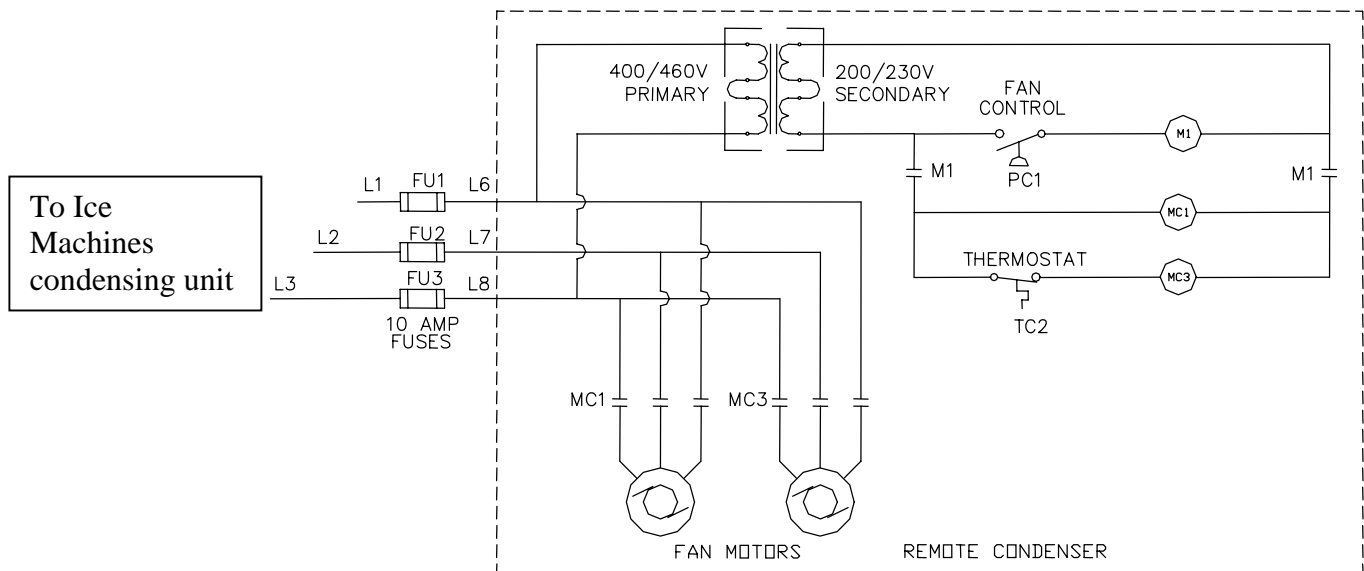

460V

FIGURE 2-11
VT80 & VT100 Remote Air Cooled Condenser Wiring

Note: Fan control pressure switch is located in air cooled condenser control panel on VT80 & VT100's with remote condensers. On VT40's and VT60's, fan control pressure switch is location on condensing unit (highside).

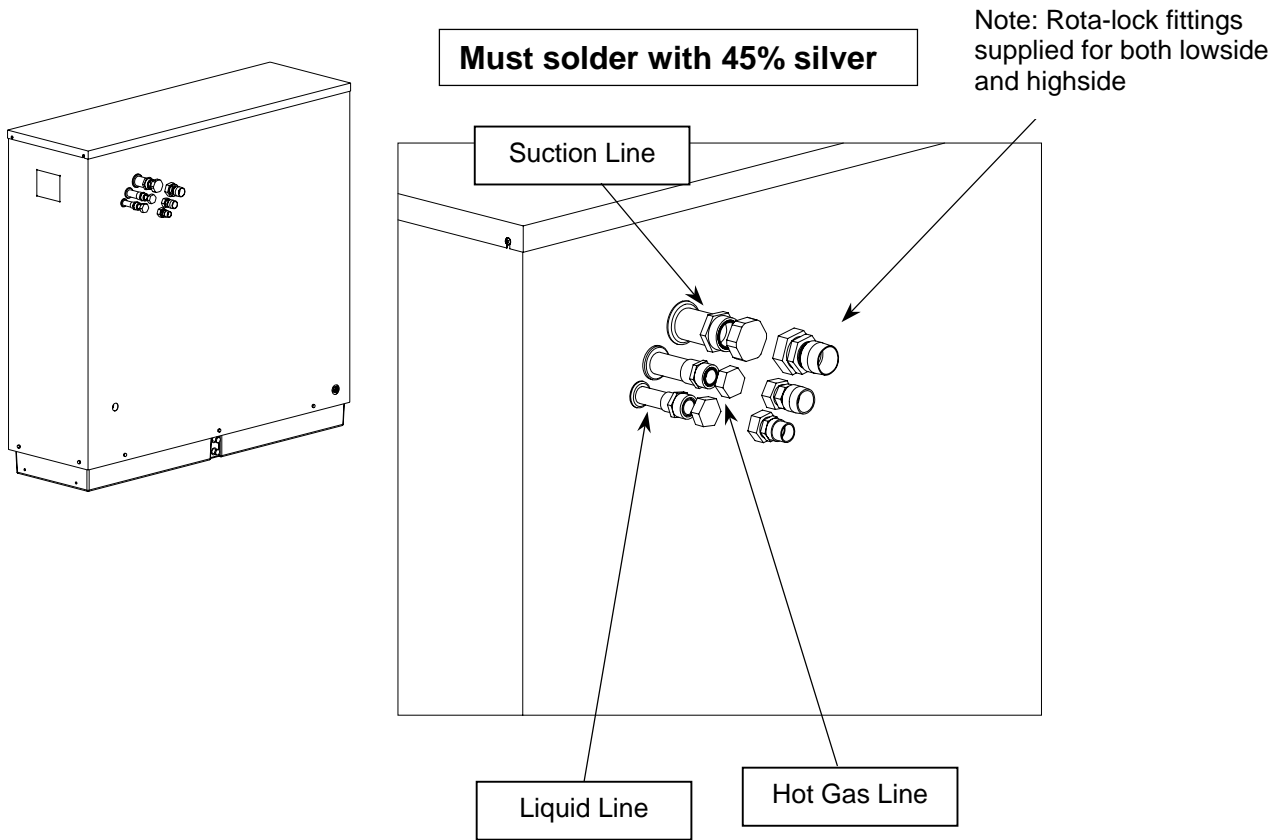
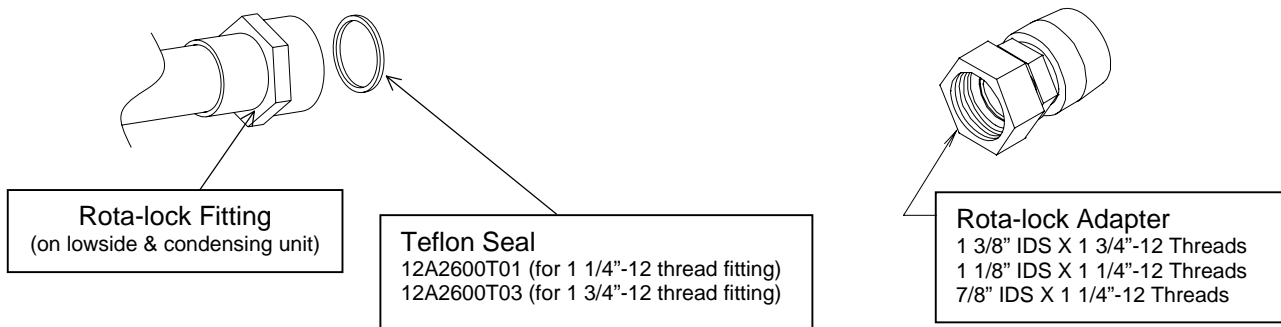

FIGURE 2-12
VT Lowside Connections



Rota-lock Adapter		Teflon Seal	Where Used	
Part #	Description	Part #	VT40	VT60
12A2396A0501	1 1/8" IDS X 1 1/4"-12Thrd	12A2600T01	N/A	Hot Gas Line
12A2396A0601	1 3/8" IDS X 1 3/4"-12Thrd	12A2600T03	Suction Line	Suction Line
12A2396A0701	7/8" IDS X 1 1/4"-12Thrd	12A2600T01	Liquid & Hot Gas line	Liquid Line

TABLE 2-5
Rota-lock Adapters

Note: See Refrigerant Line Size TABLE 2-3 for line sizes

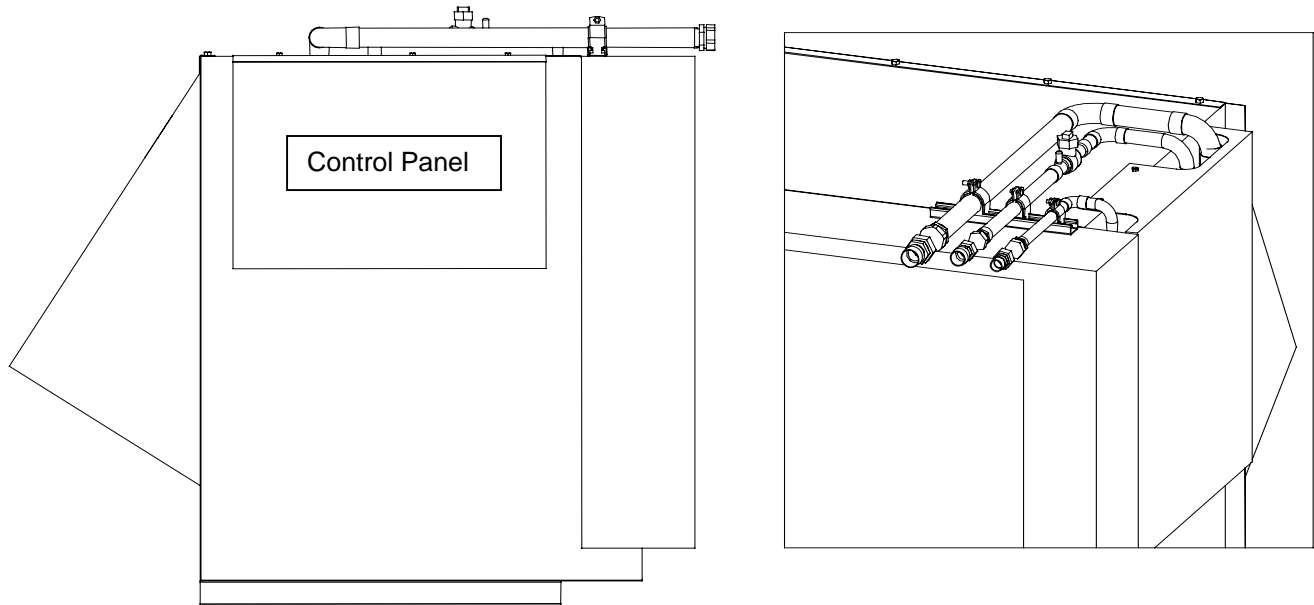

FIGURE 2-13
VT60 Condensing Unit Connections

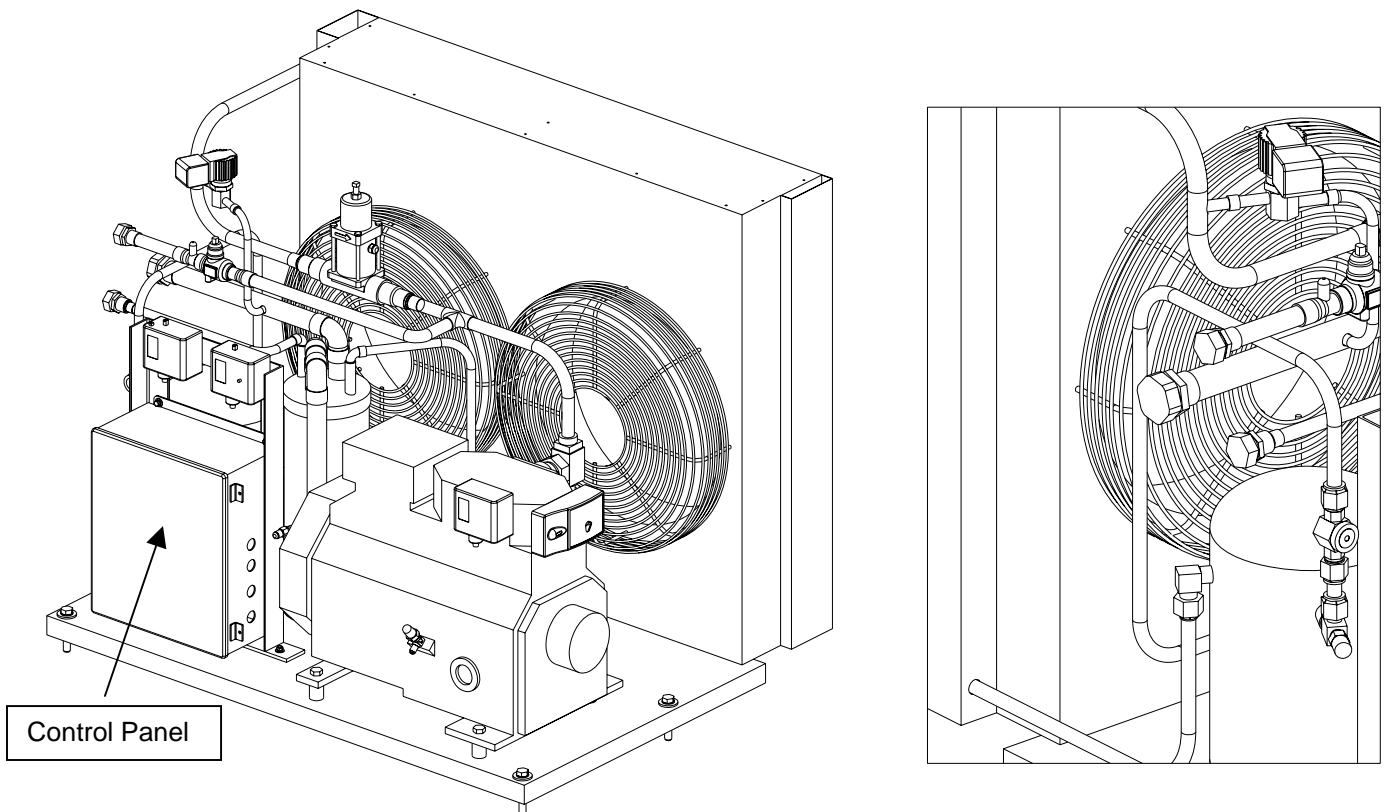

FIGURE 2-14
VT40 Condensing Unit Connections

Installation Instructions

Storing Ice. When storing ice in a bin, make sure the bin control sensors is mounted in the bin properly. The sensor should be mounted on the right side of the bin approximately 8" –12" from the top of the bin.

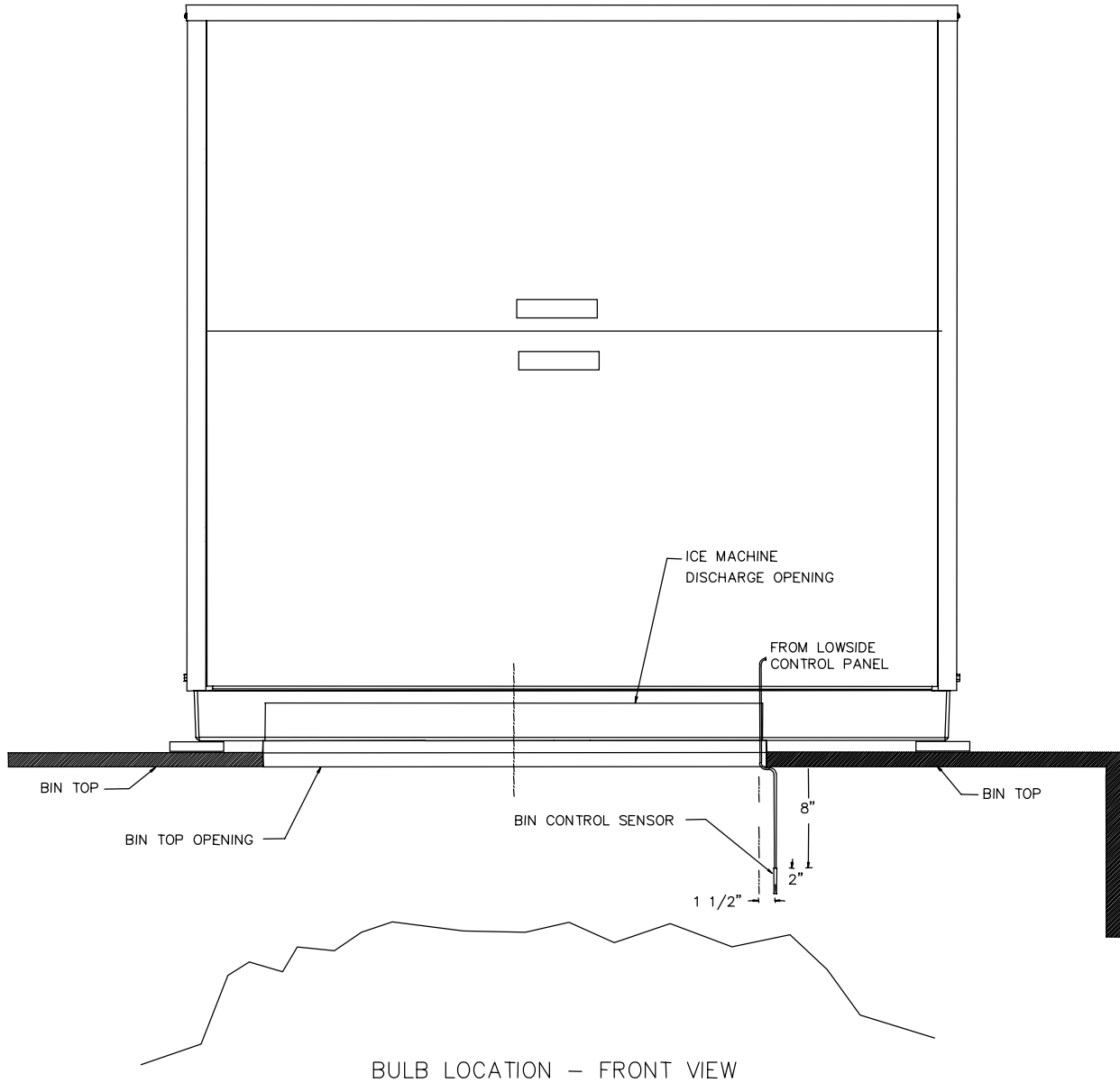
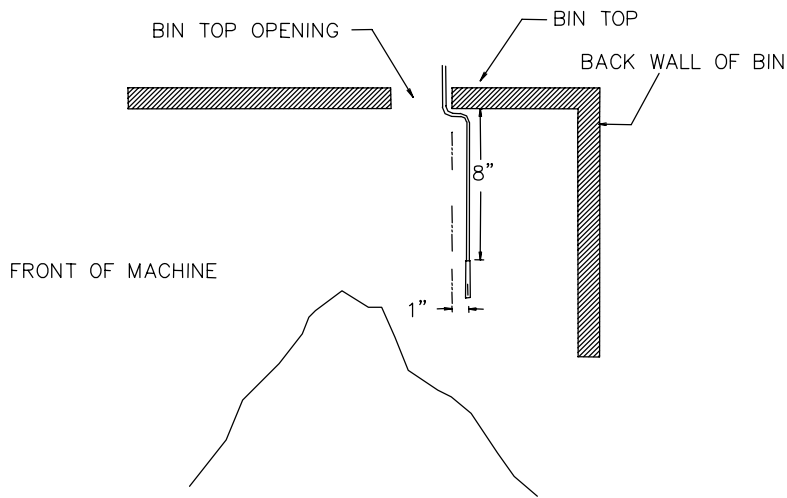

FIGURE 2-15A
Bin Control Sensor Installation



BULB LOCATION – SIDE VIEW

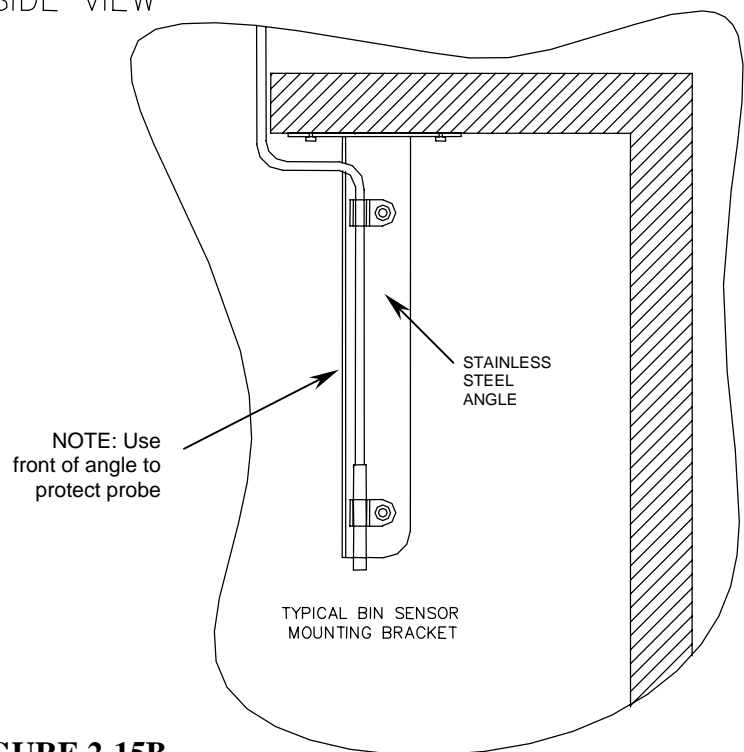

FIGURE 2-15B
Bin Control Sensor Installation

Ice Bin Capacity. Crushed ice weighs approximately 35 pounds per cubic ft. (35 lb/ft³). As ice drops into a bin, it will pile up and slope naturally at about a 45° angle. This natural slope should be taken into account when locating the bin thermostat bulb (or other bin level control) and when calculating the normal bin capacity. If the ice is spread out by hand in the bin for maximum storage capacity, make sure a hazard is not created by allowing ice to back up into the chute and jamming the cutter. Always allow enough room below the chute for at least one harvest.

- VT40 = 25-30 lbs. / cycle
- VT60 & VT80 = 35-40 lbs. / cycle
- VT100 = 47-52 lbs. / cycle

2-14

Installation Instructions

Vogt[®] VT Service Manual

Blank

3. Model Specifications

Electric	VT-40	VT-60	VT-80	VT-100
Volts/ Phase/ Hertz	208/230-3-60			
Total F.L.A. Rating	46.1	56.4	67.2	80.6
Minimum Circuit Ampacity	54.0	66.9	80.4	97.1
Maximum Circuit Breaker	90	110	135	165

Compressor (Copeland® Discus®)

Compressor	5.5 HP	7 HP	10 HP	12.5 HP
Voltage Range (208/230)	187-253			
Nameplate Rating (Amperes)	31.5	42.0	52.6	66
Locked Rotor Rating (Amperes)	161.0	215.0	278	374
Oil (Suniso) – Mineral (R22)	3GS			
Oil (Copeland) – Synthetic (R404A)	Ultra 32 – 3MAF or Mobil EAL Arctic 22 CC			
Oil – amount (Initial Charge / Recharge - oz)	125 / 115		135 / 125	

Chopper Motor (Marathon)

HP	1/2 HP
Voltage	230 V
FLA	3.7 A

Water Pump Motor (Hartell)

HP	1/12 HP
Voltage	208-230 V
FLA	1.0 A

Condenser Fan Motors

HP	2 @ 1/2 HP			
Voltage	208-230 V			
FLA (Total for both motors)	8.4 A	8.2 A	8.4 A	6.4 A

Field Connections (Remote Condensing Units Only)

Suction	1 3/8 ODS	1 3/8 ODS	N/A	N/A
Hot Gas	7/8 ODS	1 1/8 ODS	1 1/8 ODS	1 1/8 ODS
Liquid	5/8 ODS	7/8 ODS	7/8 ODS	7/8 ODS

General Info

Sight Glass (Sporlan)	SA 15U	SA 17S	SA 17S	SA 17S
Filter Drier (Sporlan)	C-415	RC-4864	RC-4864	RC-4864
Refrigerant Charge	16 lbs.	32 lbs.	35 lbs.	40 lbs.
Inlet Water Line	1/2" FPT			
Water Tank Drain & Water Tank Overflow	1/2" FPT			

Control Settings (approximate)

	R22		R404A	
	Cut-in	Cut-out	Cut-in	Cut-out
Fan Switch (PSIG)	220	200	250	230
Low Pressure Safety (PSIG)	20	10	20	10
Harvest Hold Pressure Control	45	60	65	80
High Pressure Safety (PSIG)	Manual	300	Manual	350
Oil Pressure Control (Differential)	9 PSIG (Manual Reset)			

Listed refrigerant charges are for close coupled and skid mounted machines as tested.

Remote installations of extended length will require additional refrigerant.

Note: Electrical data based on air cooled units

Vogt Ice Vertical Tube Model Number Structure

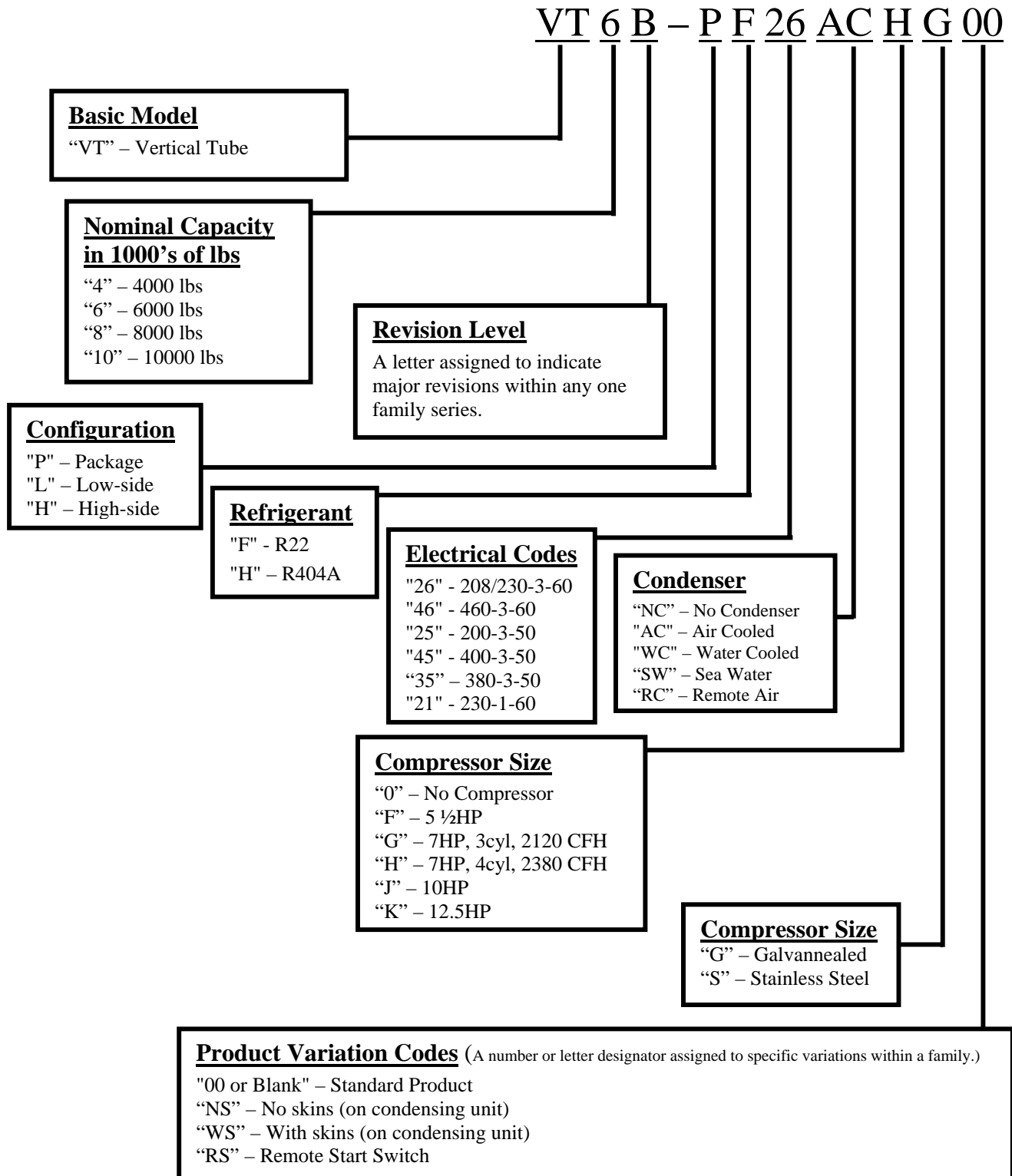

4. Initial Startup

START-UP PROCEDURE

Prior to start-up, the following items should be checked:

1. Make sure all packing has been removed from the lowside unit. To do this, you must remove the upper and lower evaporator housing covers. Remove to upper casing first, then the lower. (See Figure 4-1)

CAUTION !!! Make sure Lower Evaporator Housing Cover is put back on machine before power is applied.

2. Open all service and ball valves. (Figure 4-4 & 4-5)
3. Check that bin switch is installed correctly. (Figure 2-5)
4. Check voltage and verify with nameplate.
5. Verify adequate water supply and sump level of two (2") inches.
6. Verify Ice/Off/Clean selector switch on the lowside unit is in the "Off" position.
7. Energize unit two (2) hours prior to starting to energize crankcase heater.
8. Ensure that circuit breakers in condensing unit control panel are in the "on" position. (Figure 4-2)

Note: "Control Power" Light will be ON when power is supplied to Lowside

At completion of above eight (8) items, machine is ready to run. Place selector switch in "Clean" position and check water flow. (If the pump does not come on, press the green "Manual Harvest" button). Place selector switch in "Ice" position and press "Manual Harvest" button. The machine will start in a harvest mode then proceed to the Freeze mode. Observe machine operation. Make no changes to any settings on machine for six (6) cycles. Verify pressures settings conform to service manual information. Do not trust pressure control scales.

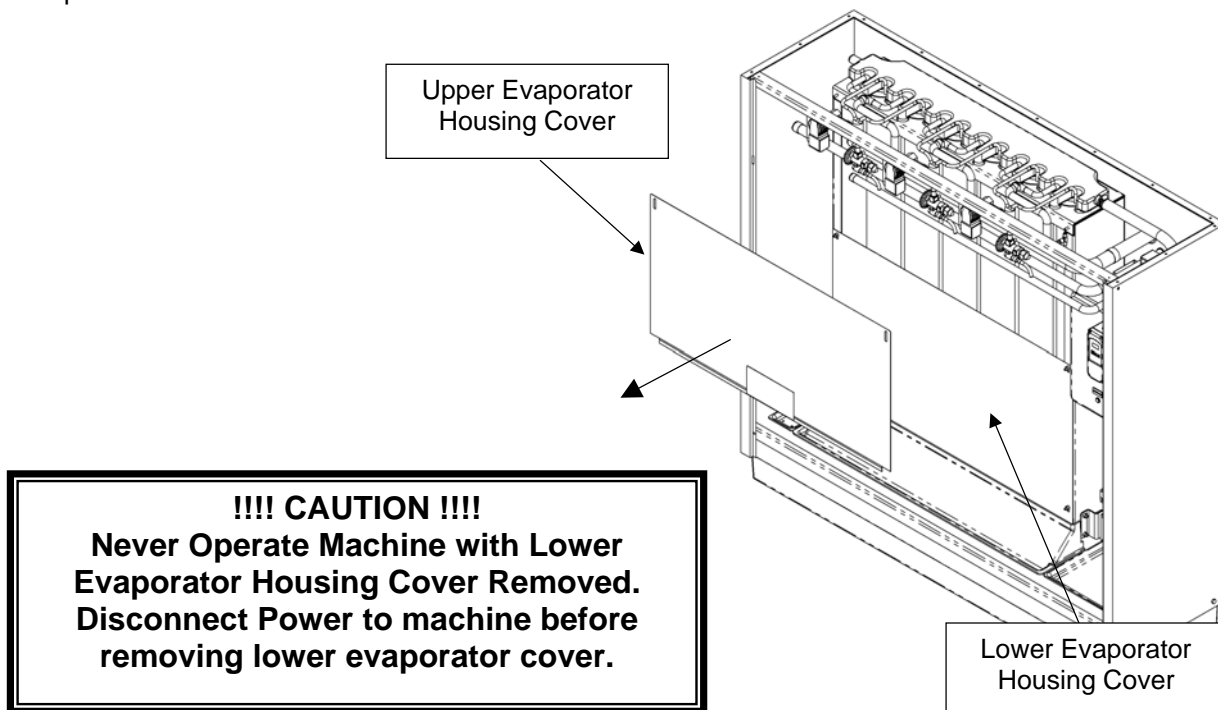

FIGURE 4-1
Evaporator Housing Covers (Upper & Lower)

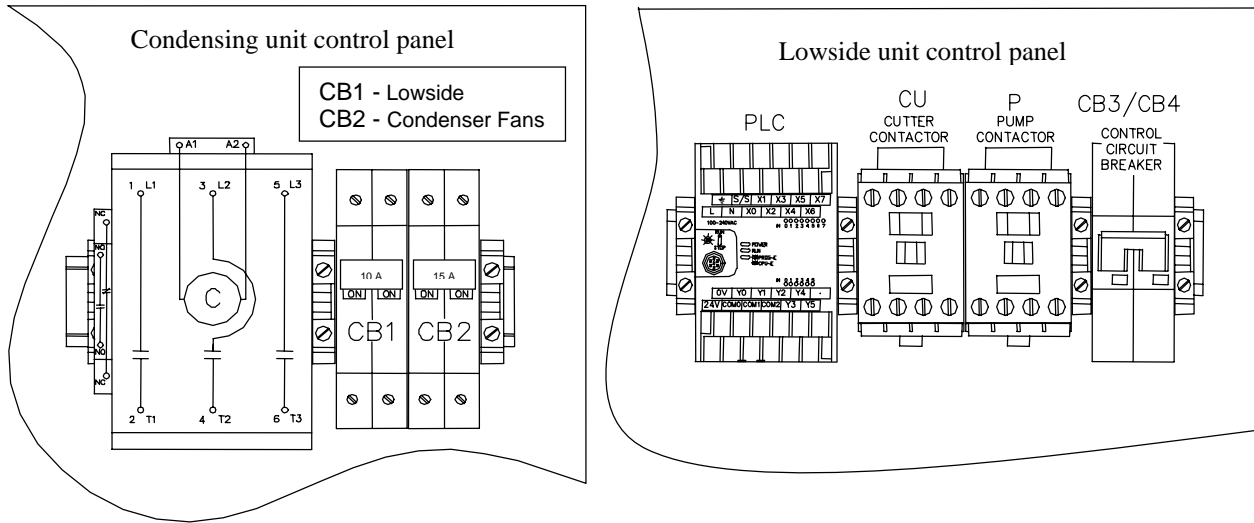

FIGURE 4-2
Circuit Breakers (200/230V machines)

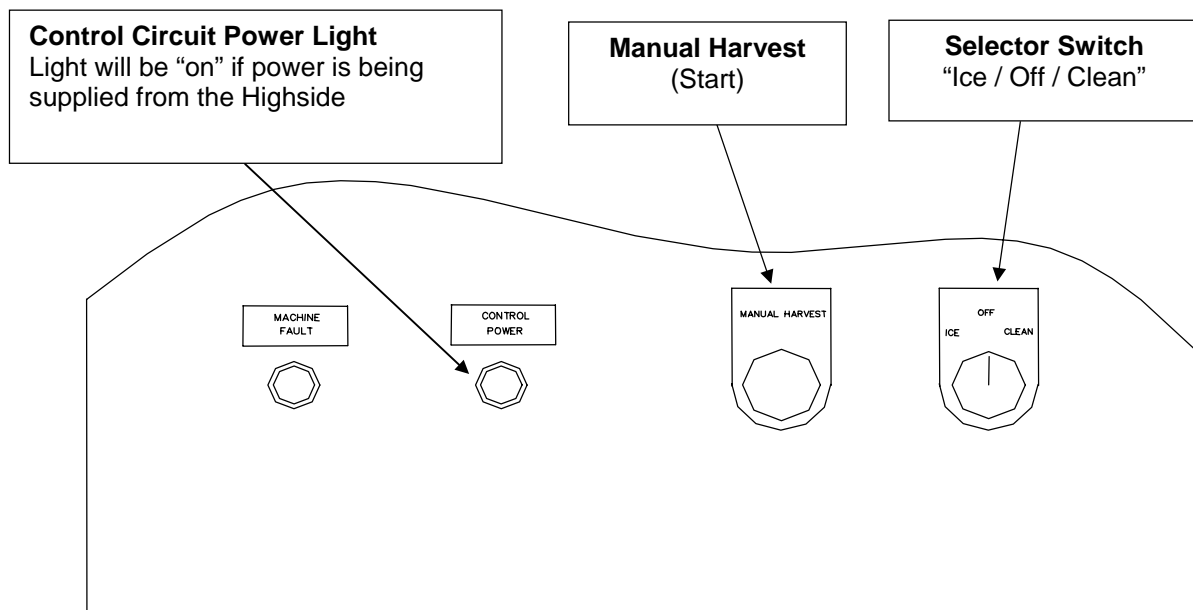

FIGURE 4-3
Lowside Control Panel Front

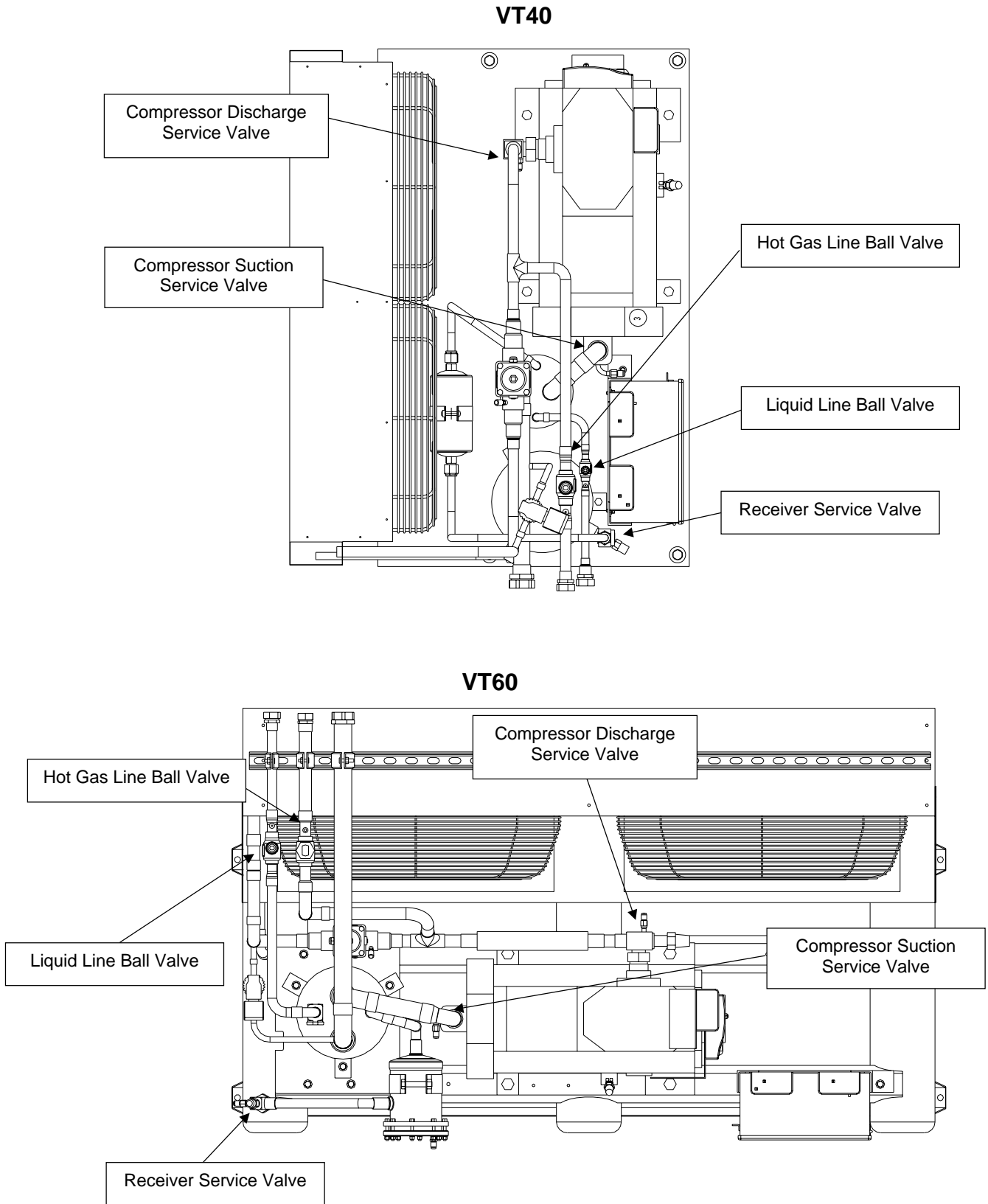

FIGURE 4-4
Service and Ball Valve Locations

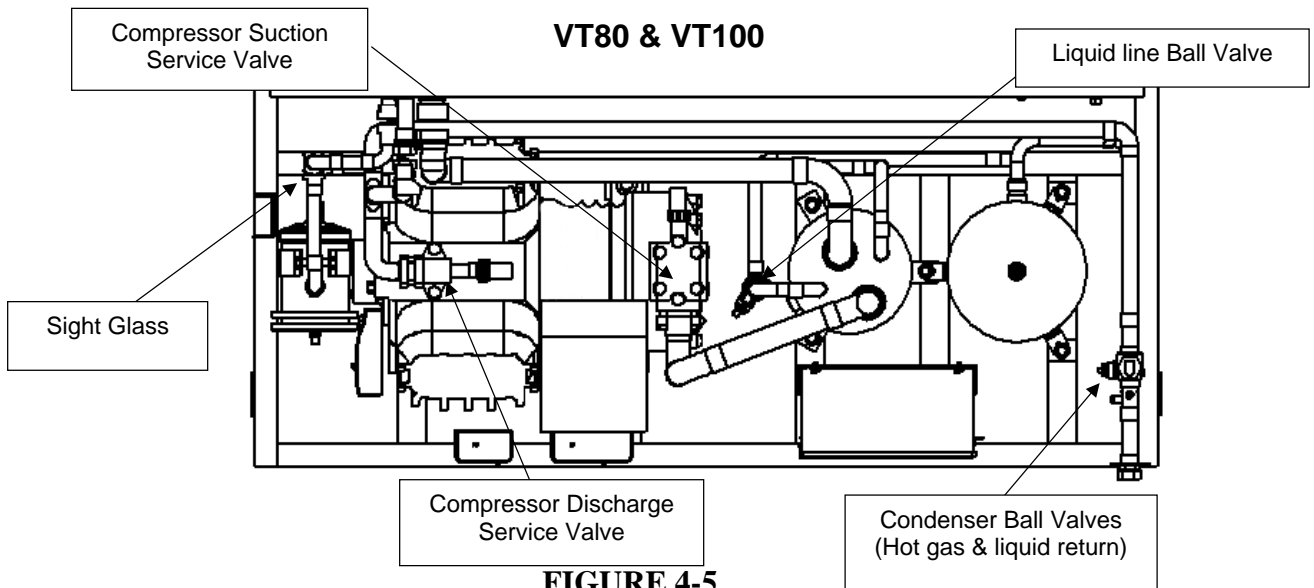

FIGURE 4-5
Service and Ball Valve Locations

Adding Refrigerant / System Charging: To charge the system with cycling fans, observe sight glass during the ice making cycle. When the fans cycle off, the sight glass should clear in 8 to 10 seconds.

- If it takes longer than 10 seconds to clear the glass, the unit is undercharge. Add refrigerant to system at compressor suction port or the 1/4" access fitting on suction line. (See Figure 4-6)
- If the glass clears in less than 8 seconds, the unit is overcharged. Remove refrigerant from system following EPA standards.

Note: *Do not charge to a full sightglass. Do not charge in a harvest cycle.*

If packaged unit is totally out of refrigerant, add amount specified on machines nameplate.

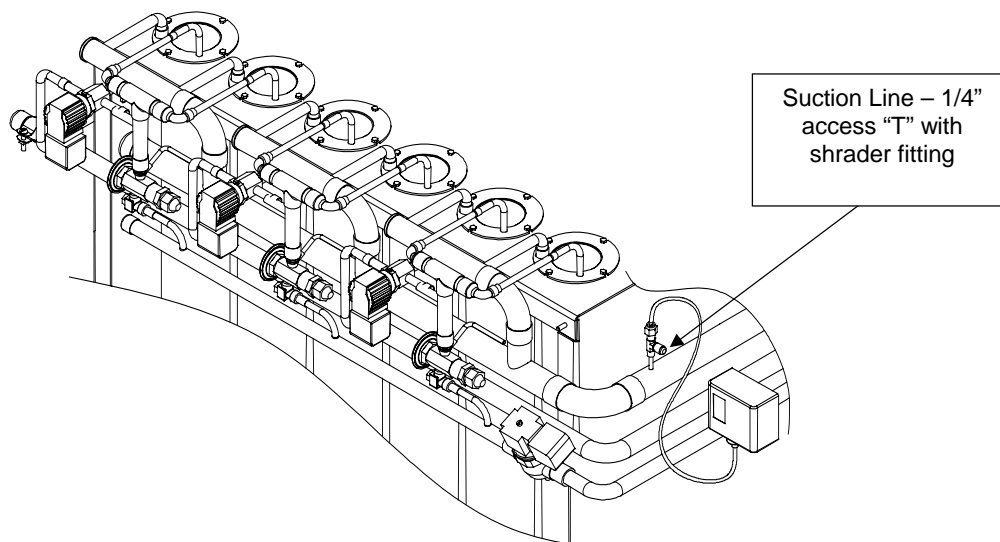

FIGURE 4-6
Access Fitting for Charging System

Removing Refrigerant: To remove refrigerant from an overcharged system, refrigerant gas may be removed from suction line ¼" access fitting (See Figure 4-7). For quicker removal, liquid refrigerant may be reclaimed from the liquid line.

VT80/VT100 – access fitting on liquid line ball valve

VT60 – access fitting on receiver rota-lock valve

VT40 – access fitting in liquid line

Note: Follow all EPA regulations and guidelines when handling refrigerant.

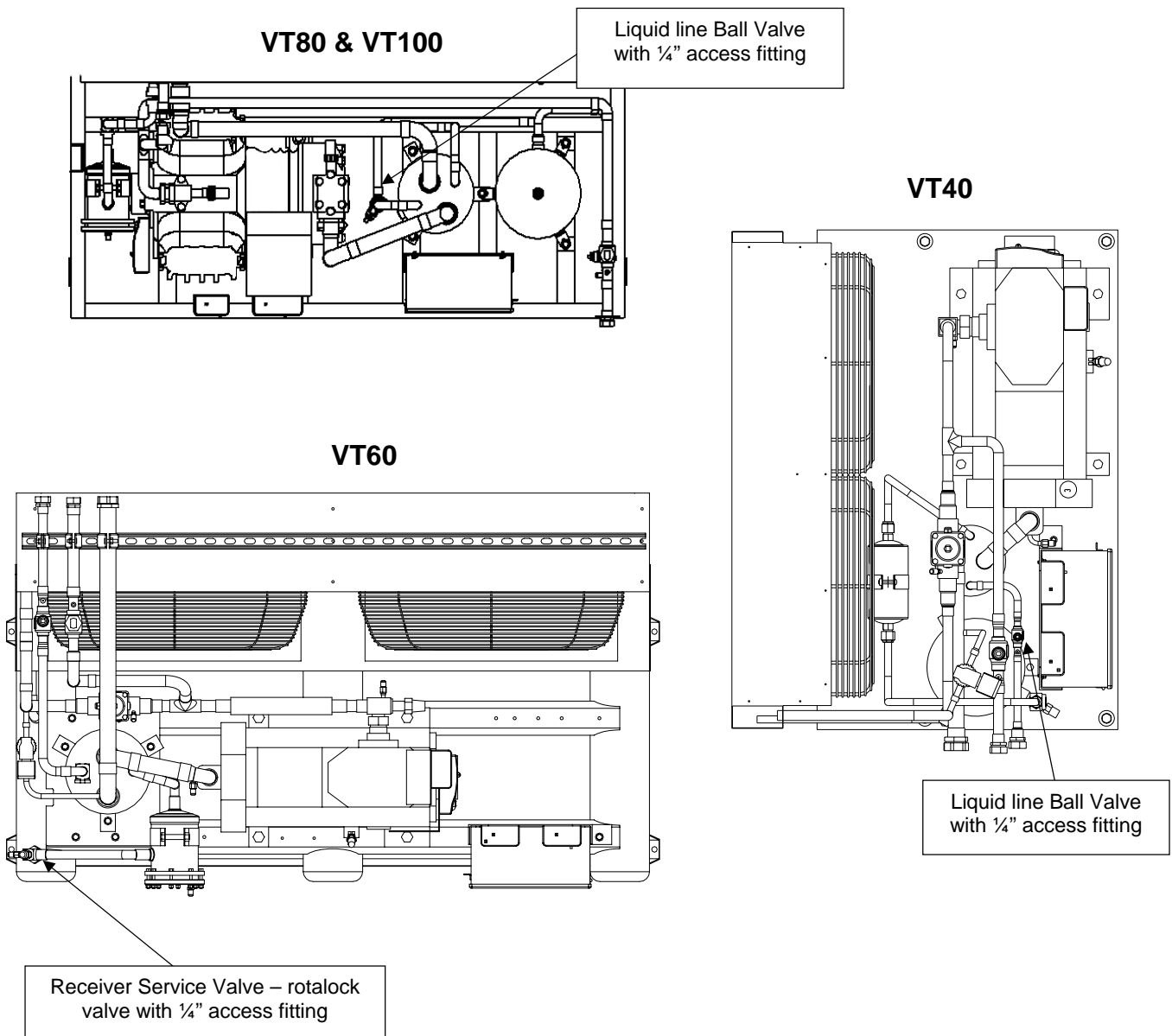

FIGURE 4-7
Access Fitting for Removing Refrigerant

5. Electrical Controls

CONTROLS

Explanation. The VT-Series ice machine is controlled by a PLC (Programmable Logic Controller). The PLC controls the sequence of events and monitors the ice machine functions. The operational sequences of the VT-Series ice machine can be described best as a series of six different modes. Each mode identifies and defines a sequence of events that occur while in that mode and thereby cause it to move to the next mode. Only one mode is active at a time.

Start-Up Mode. The start-up mode is a function which prevents the premature automatic starting of the machine at the time of installation, after a power interruption, or after a machine fault. During Start-up, the machine will not start for two hours. This gives the crankcase heater time to boil any refrigerant out of the compressor. The start-up mode may be bypassed at any time by pressing the “Manual Harvest” (Start) button to immediately advance to the standby mode.

NOTE: While the machine is in the Start-Up Mode, the Fault Indicator light will remain “on” (will not be blinking).

! CAUTION !

If the power has been turned off to the machine, make sure the compressor crankcase is warm and there is no liquid refrigerant in with the oil before restarting the unit.

! CAUTION !

Standby Mode. The standby mode is a decision making mode. It monitors the position of all the various switches in the control circuit and at the proper time decides which mode to advance to next.

Note: R404A machines are pumped down while in the Standby mode. If the pressure comes back up after 3 minutes, (the low pressure switch “closes”), the machine will go to the Pumpdown Mode.

Freeze Mode (Freeze Cycle). The freeze mode is active during the normal ice making cycle. During this time, liquid feed valve is energized (R404A machines only) and the circulating water pump and compressor are running. The freeze time is determined by the PLC analog timer (0-3.5 min) plus 5 minutes. (Minimum freeze cycle time = 5 minutes, maximum freeze cycle time = 8.5 minutes)

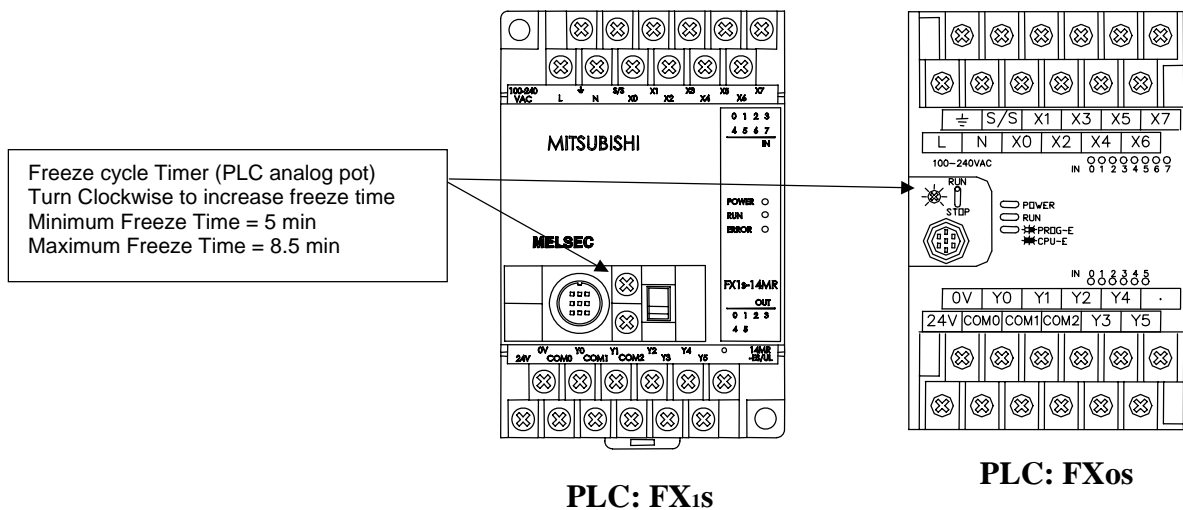

FIGURE 5-1
PLC – Programmable Logic Controllers

Electrical Controls

Harvest Mode (Thaw Cycle). The harvest mode is normally initiated at the termination of the freeze mode. At this time, the circulating water pump stops and the liquid feed valve closes (R404A machines only). After five seconds, the “D” (thaw gas) solenoid valves open and the chopper motor starts. On split VT40’s & VT60’s, the hot gas loop valve energizes and VT80 & VT100 the suction stop valve energizes when the chopper and thaw gas valves open. When the suction pressure reaches the set point on the Harvest Hold (HH) pressure switch (PLC input #2 light will turn “off”), the harvest timer will begin to time. The harvest timer is an internal timer in the PLC set for 45 seconds.

The harvest mode is terminated by the PLC thaw (harvest) timer at which time the machine will begin another freeze cycle. The harvest mode can also be terminated manually by pushing in the “Manual Harvest (Start)” button.

Increasing Harvest Time – To increase the harvest cycle time, raise the HH pressure switch cut-out setting. (See Figure 5-2) This will increase the time it takes for the suction pressure to reach the set-point on the switch, thereby increasing the harvest time.

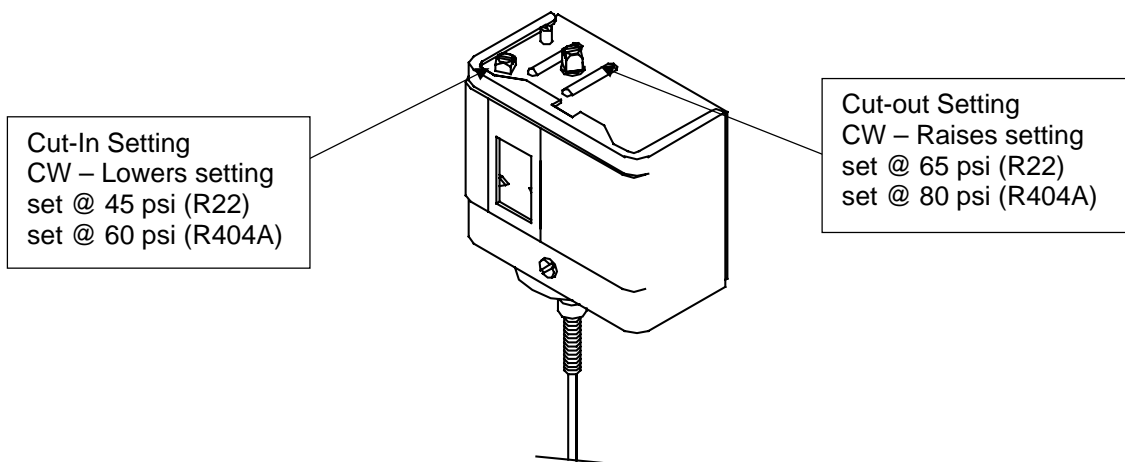

FIGURE 5-2
Harvest Hold Pressure Switch
 (located on top of lowside control panel)

Long Harvest Cycle Safety – The PLC monitors harvest cycle time. If the suction pressure does not reach the HH pressure switch set-point within **3 minutes**, the machine will shut down and go to the Fault Mode.

NOTE: If the “Selector Switch” switch is in the “Off” position or the bin control is satisfied the machine will complete the Freeze, Harvest and Pumpdown cycle before shutting off (standby mode). Machines with R22 do not go through a pumpdown cycle before shutting off.

Pumpdown Mode (R404A machines only). All R404A machines have a liquid feed solenoid valve and go through a Pumpdown cycle before shutting off. During the Pumpdown cycle the water pump and compressor are “on” and the liquid feed solenoid valve is “closed”. The machine will run in the Pumpdown mode until the Low pressure safety switch “opens”. After shutting off on low pressure, the machine will go to the Standby mode.

Note: If the suction pressure does not reach the cut-out point on the low pressure switch within 2 minutes, the machine will fault out on a “Pumpdown Fault”.

Continuous Pumpdown (R404A machines only). While in the Standby mode, the machine will remain pumped down. After a 3 minute delay, if the pressure comes up in the freezer and the low pressure safety switch “closes” (pressure gets above 20 psig), the compressor will come “on” and pump the machine down.

Clean Mode. The “Clean” mode is considered to be a maintenance or service function of the machine. During this mode only the water pump will run.

The water pump can be stopped by simply moving the “Selector Switch” from the “Clean” to the “Off” position. To restart the water pump, move the “Selector Switch” back to the “Clean” position and press the “Manual Harvest (Start)” button. Ice machine cleaning solution can be circulated through the tubes to accomplish the cleaning procedure. If the water pump is left to run in the clean mode for more than two hours, the PLC will shut the machine off. The clean mode can be resumed by pushing the “Manual Harvest” button.

NOTE: Running in Clean mode for extended period of time can cause excessive pressure to build up in the freezer.

At the termination of the clean mode, the machine can be returned to ice making mode by putting the “Selector Switch” in the “Ice” position and pressing the “Manual Harvest” button.

Fault Mode. The VT Series is equipped with a PLC (programmable logic controller) that controls all aspects of the operation. One of the functions of the PLC is to shut down the machine when a problem arises and send a signal to the fault indicator light located on the front of the electrical panel. (Figure 5-3) The red light will blink 1 to 6 times when a problem has caused the machine to shut down. See table below for the description of the fault modes.

#	Description	Switch Reset (Auto or Manual)
1	Low Suction Pressure	Auto
2	High Discharge Pressure	Manual
3	Low Oil Pressure	Manual
4	Long Harvest Cycle	N/A
5	Cutter Motor	Auto
6	Pumpdown Fault	Auto
Solid	Power Failure	N/A

TABLE 5-1
PLC Fault Codes

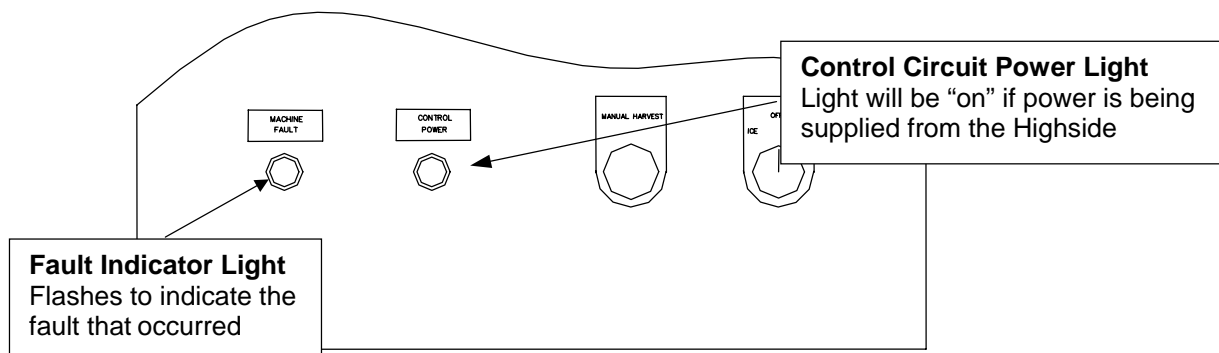
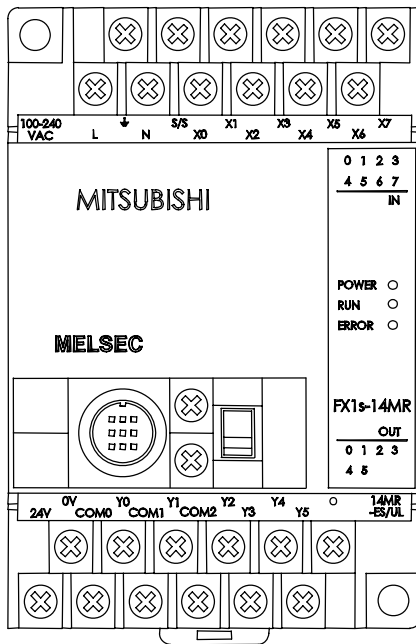
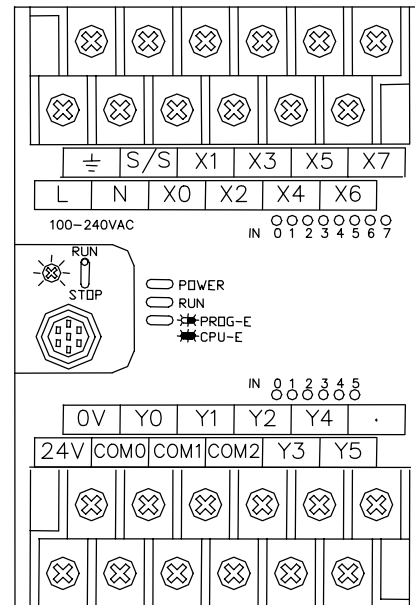

FIGURE 5-3
Lowside Control Panel Front



PLC: FX1s



PLC: FX0s

PLC Inputs

#	Description
0	Current Sensing Relay (CSR) for cutter motor
1	"On" Switch & Bin control (in series)
2	Harvest Hold (HH) Pressure Switch
3	Start / Manual Harvest Switch
4	"Clean" Switch
5	High Pressure safety ("off" when tripped)
6	Low Pressure safety ("off" when tripped)
7	Oil Safety / Compressor OL (VT80 & VT100)

PLC Outputs

#	Description
0	Machine Fault Indicator Light
1	Liquid Feed Solenoid (R404A machine only)
2	Compressor
3	N/A
4	Water Pump
5	Cutter / "D" valve / Defrost loop valve or Suction Stop valve (VT80 & VT100)

**FIGURE 5-4
PLC Inputs & Outputs**

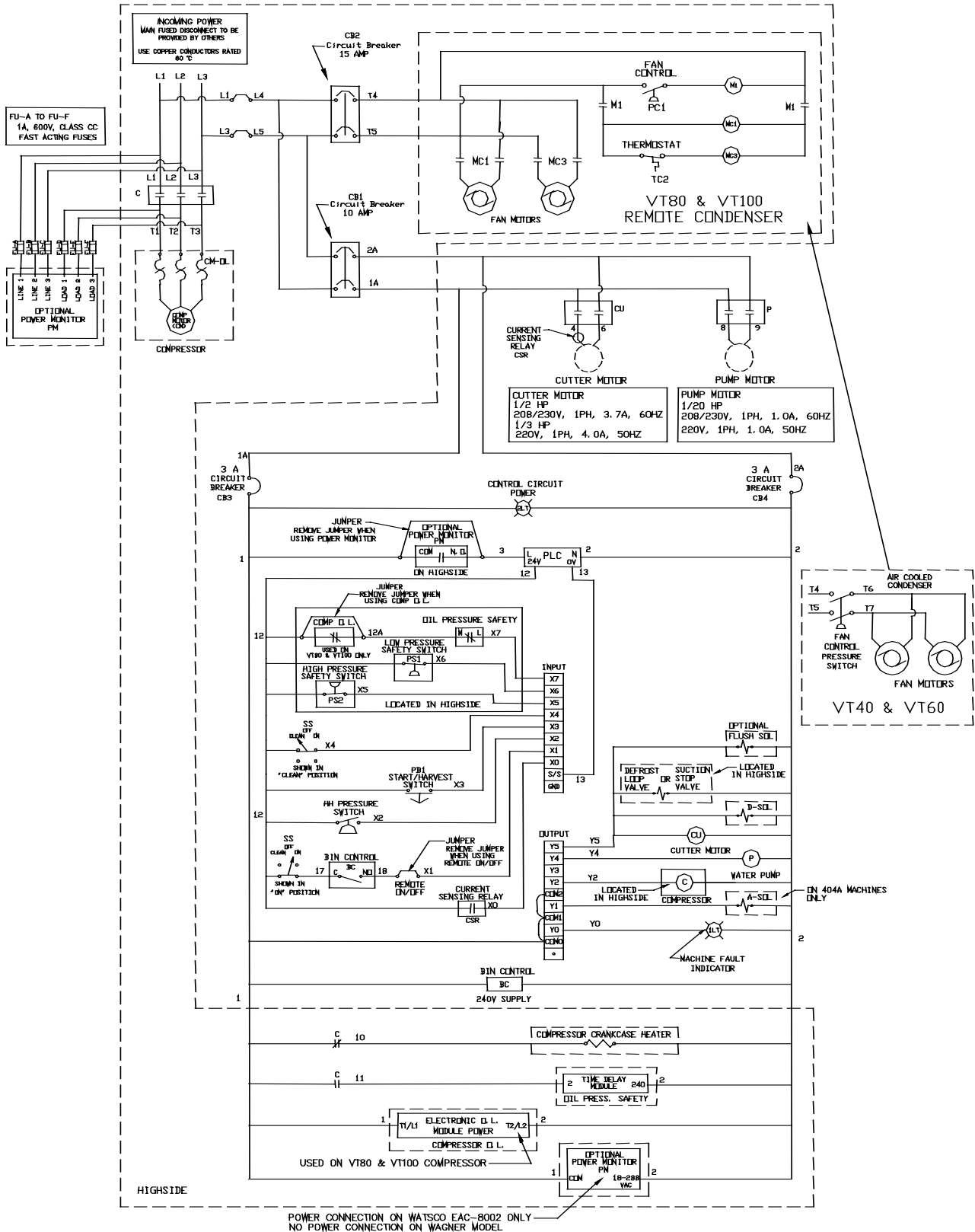

FIGURE 5-5
Complete Electrical Schematic - 208/230V (PLC)

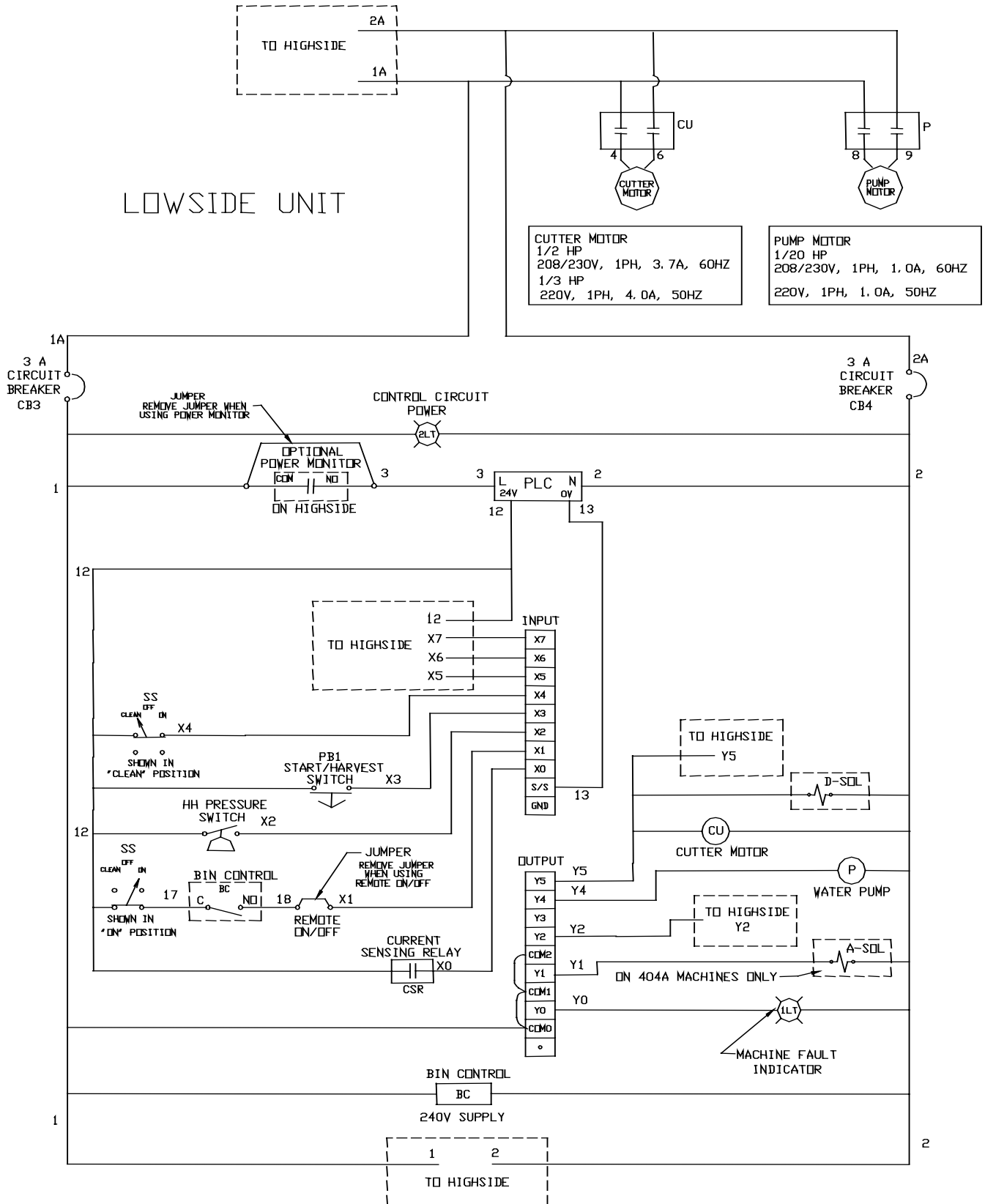

FIGURE 5-6
Lowside Unit (200/230V)

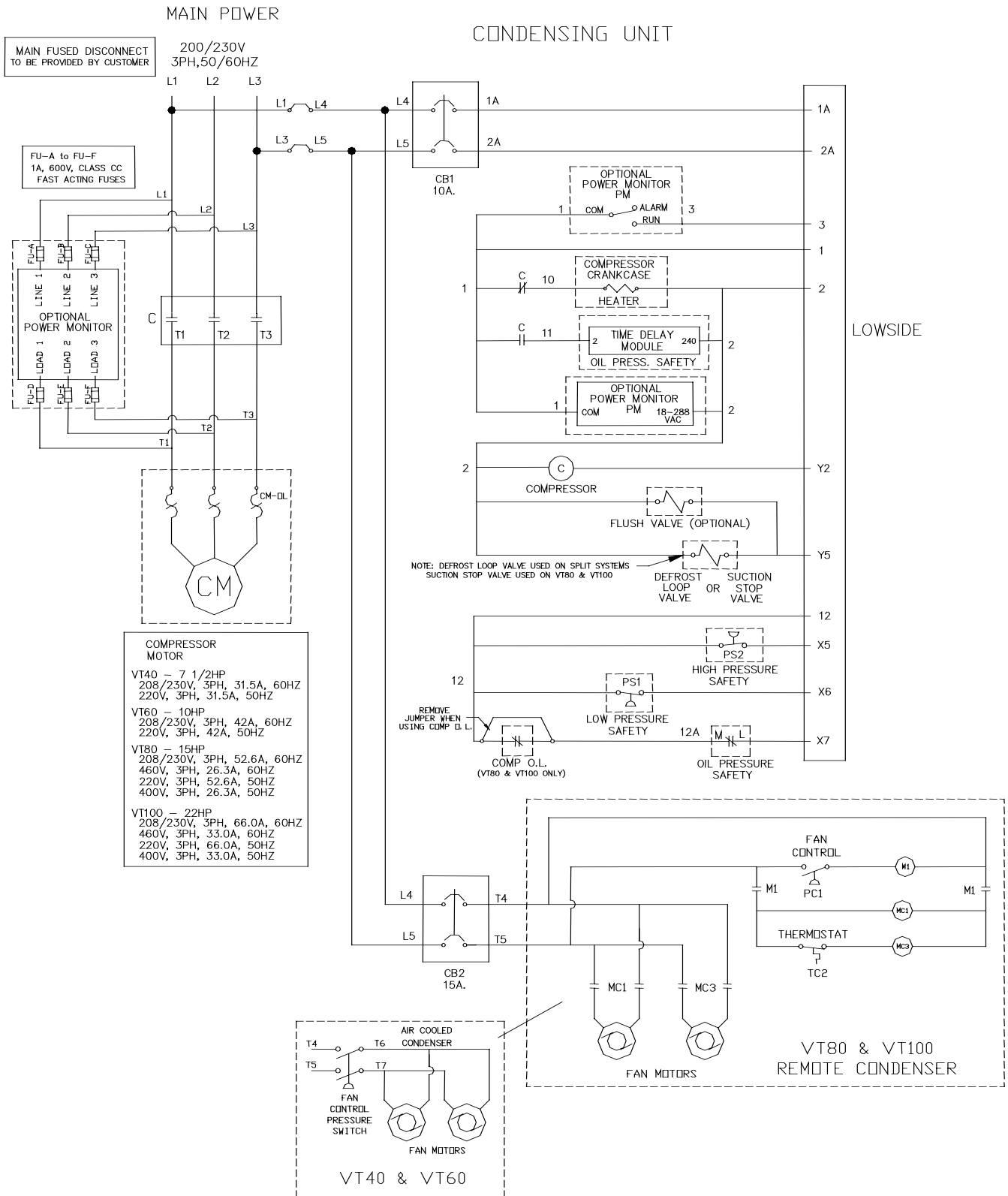
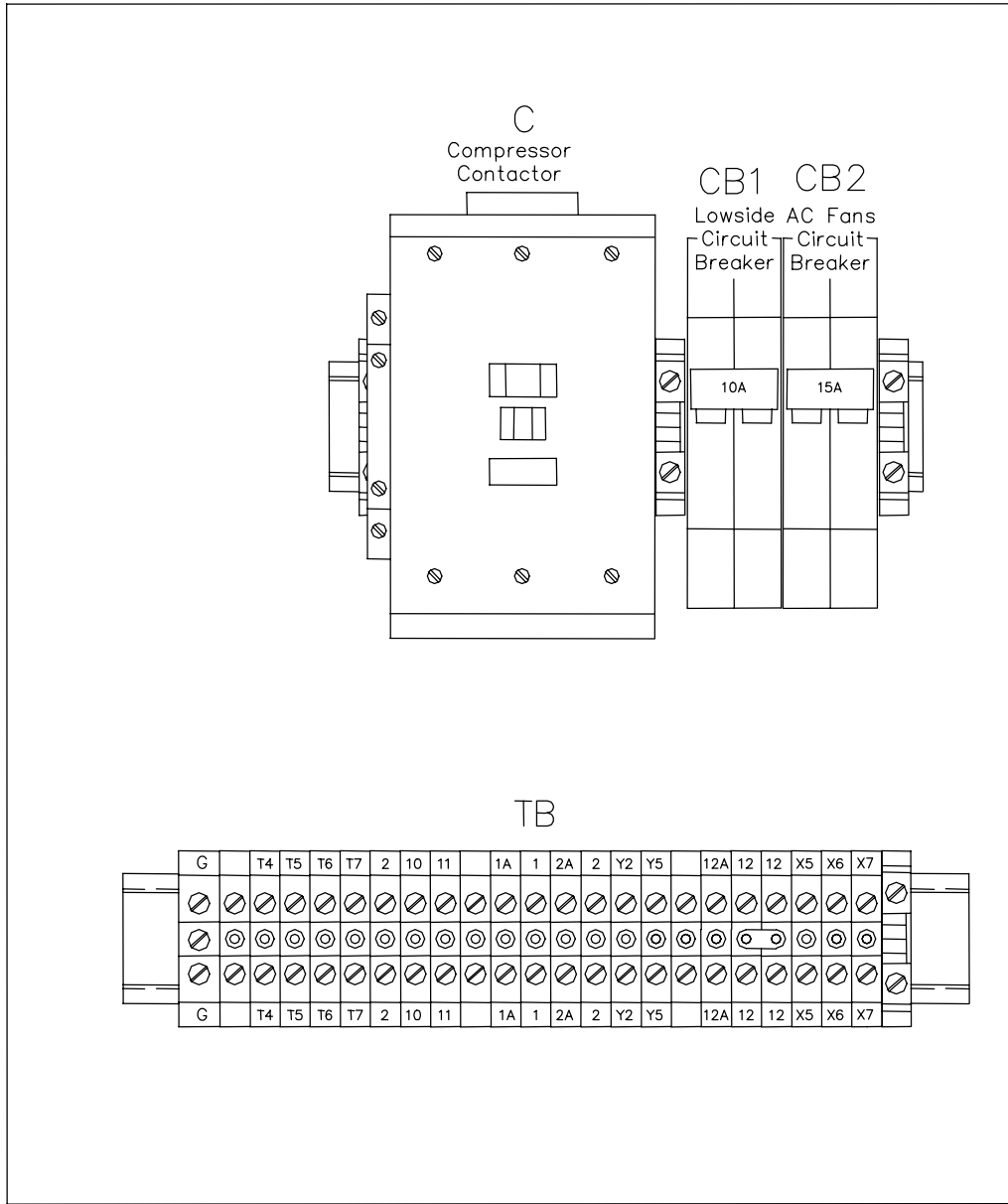

FIGURE 5-8
Condensing Unit Electrical Schematic – 208/230V (PLC)



Condensing Unit Control Panel Parts

C	12A7516E29	VT40 Compressor Contactor
	12A7516E30	VT60/80/100 Compressor Contactor
	12A7518E30	Auxiliary Contact, 1 N.O./1 N.C.
CB1	12A7515E18	Lowside Circuit Breaker, 2 pole (10Amp)
CB2	12A7515E19	AC Fan motors Circuit Breaker, 2 pole (15Amp)
TB	N/A	Terminal Block

FIGURE 5-9
Condensing Unit Control Panel (PLC)

Blank Page

6. Maintenance

Preventive Maintenance

For The Manager Who Depends Upon This Machine For Efficient Operation.

“Preventive Maintenance” simply means that you or a delegated employee makes a daily visual check of your Vogt Ice machine. Here is what to look for and why:

Daily checklist:

1. Is the machine running or is the bin full
2. Bin doors kept closed
3. Thermostat bulb in bracket
4. Does all ice discharge during harvest
5. Cleanliness
6. Unusual noises

Why? When you make these simple observations on a daily basis, you insure the smooth production of ice for your facility. When you are aware of the proper operating conditions and observe them on a daily basis, changes in these conditions can alert you to changes in the operation of the machine which may require maintenance--long before a service situation arises.

Note To Manager or Owner:

The following page is a complete Preventative Maintenance Schedule that should be performed each 90 days. The Preventative Maintenance page may be copied and given to your service person. It should be signed, dated, and returned to you for permanent record.

Preventive Maintenance Program

Model # _____ Serial # _____ Date _____

Customer/Address _____

Mgr. Name _____ Service Tech Name _____

The following service performed and checked:

- Last maintenance performed (approx. date) ___/___/___
- Scale condition of water tank & tubes (good - fair - poor)
- All drains freely draining (water tank, drip pan, ice bin)
- Ice machine cleaner circulated through system
- AC condenser clean (if applicable)
- Voltage at machine (actual reading) L1-L2 _____, L2-L3 _____, L1-L3 _____
- Compressor amps (halfway through the freeze cycle) L1 _____ L2 _____ L3 _____
- Cutter motor amps (cutting ice) _____
- Water pump amps _____
- AC condenser motor amps (if applicable) _____
- Crankcase heater heating
- Refrigerant charge (okay - high - low)
- Leak checked system _____ leaks found & repaired
- Compressor oil level (i.e, 1/4 - 1/2 - 3/4 - low - high)
- PSIG, low pressure switch set @ 10 psi
- PSIG, high pressure switch set @ 300 psi (R22) / 350 psi (R404A)
- Bin stat(s) installed and operate properly
- Make-up water float valve adjusted okay

_____ Suction PSIG at end of freeze
_____ Suction PSIG during harvest (high/low)
_____ PSIG, Discharge pressure regulator (Water cooled only)
_____ Discharge PSIG at end of freeze
_____ °F/°C at machine
_____ °F/°C outside ambient (at condenser if applicable)
_____ °F/°C make-up water temperature
_____ Freeze cycle time (minutes)
_____ Harvest cycle time (minutes)
_____ First ice out (seconds)
_____ All ice out (seconds)
_____ Pounds of ice per cycle

Capacity check: ice # per cycle X (1440 / total cycle time (min)) = lbs./24 hrs.

Remarks: _____

Air-Cooled Condenser Cleaning. Visual inspection will indicate if dirt is accumulating and clogging the fin face of the condenser. A vacuum cleaner, compressed air, or a brush may be used to remove any accumulation of loose dirt from the fin section of the condenser.

For the removal of more severe accumulations of dirt or foreign materials, a detergent-type cleaner can be used. This cleaning agent can be supplied by your local refrigeration supply house. Follow the manufacturer's instructions when using a liquid cleaner.

If fins have been damaged, they should be straightened with the proper fin comb.

Compressor Oil. In starting and charging the unit, the oil sight glass in the crankcase of the compressor should be watched carefully for the first hour to make certain the proper lubrication is being maintained. The oil may become low in the crankcase on an initial start-up if the electrical current has been interrupted to the machine, thus de-energizing the compressor crankcase heater.

Before starting the machine again, the heater should be energized for a time period of at least two hours to evaporate refrigerant that may have condensed in the crankcase during the shutdown period. If the oil level is low after start-up, it should begin to return after a short period of operation.

The oil level should be checked frequently, particularly during the start-up operation, to see that a sufficient amount of oil remains in the crankcase. While it is important to observe the oil splash during operation, the true level can be obtained only when the compressor is stopped. With the compressor idle, the oil level should be between 1/2 to 3/4 of the sight glass, but not above the top of the sightglass.

Although the machine was shipped with the oil charge, which was originally added for the test operation, it may be necessary to add some oil when or if new refrigerant is added to the system.

An oil pump should be used to force any oil that may be required into the system. Oil may be added to the compressor of all units through the compressor oil charging port. Air should be purged from the oil pump discharge line by forcing some oil through the line before tightening the charging port.

R22 - Dual Inhibited Sunisco 3GS (Viscosity 150) or equal.

R404A - Ultra 32 – 3MAF, Mobil EAL Arctic 22 CC or equal. See page 3-1 for amount.

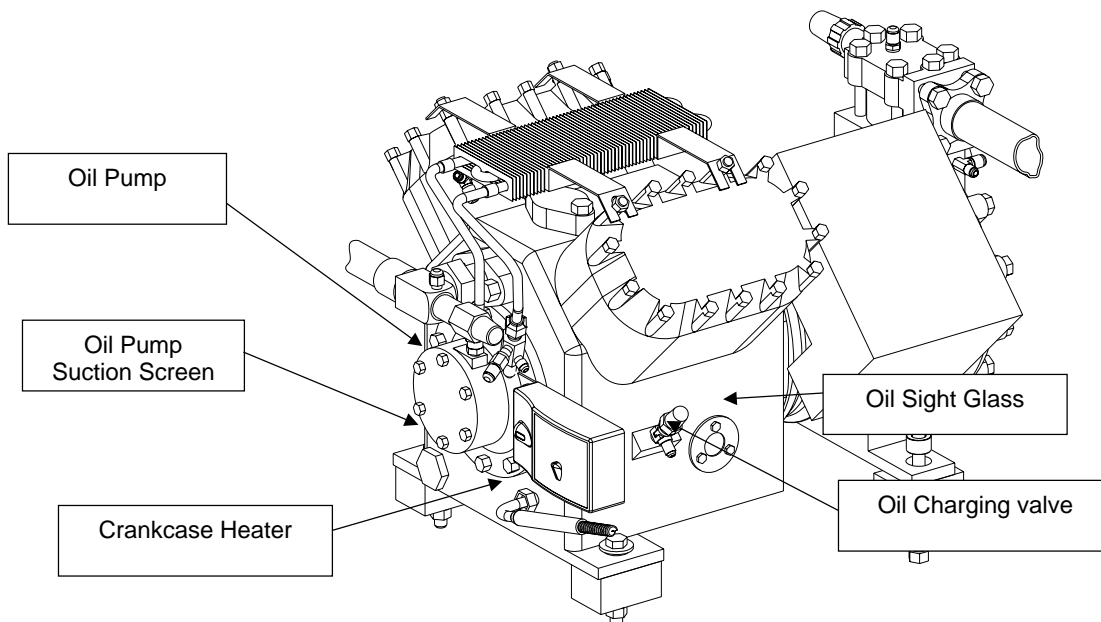

FIGURE 6-1
Copeland Discus Compressor (VT80)

Chopper Gear Reducer Oil. The oil level for the gear reducer should be checked if there is evidence of a leak. It should be level with the plugged opening in the side of the gear housing. Use Mobile 600W cylinder oil or equal.

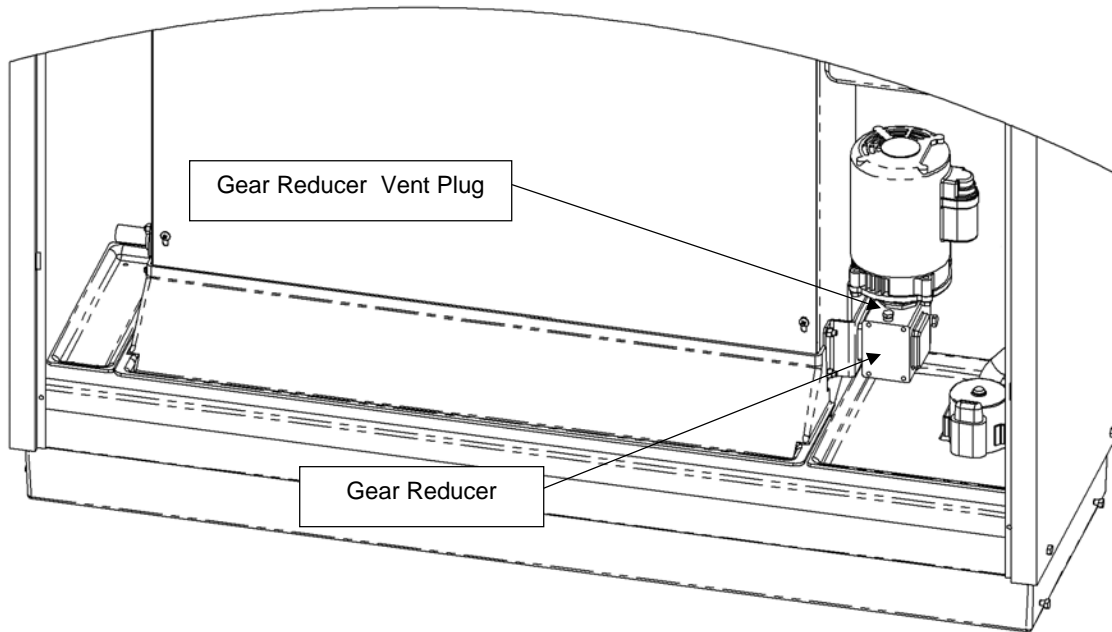

FIGURE 6-2
Gear Reducer

Water Distributor. At times it may be necessary to clean the plastic water distributor. Remove the water supply tube by removing the hose clamp. The water distributor may be soaked in ice machine cleaner. Make sure all holes are free of dirt and calcium buildup.

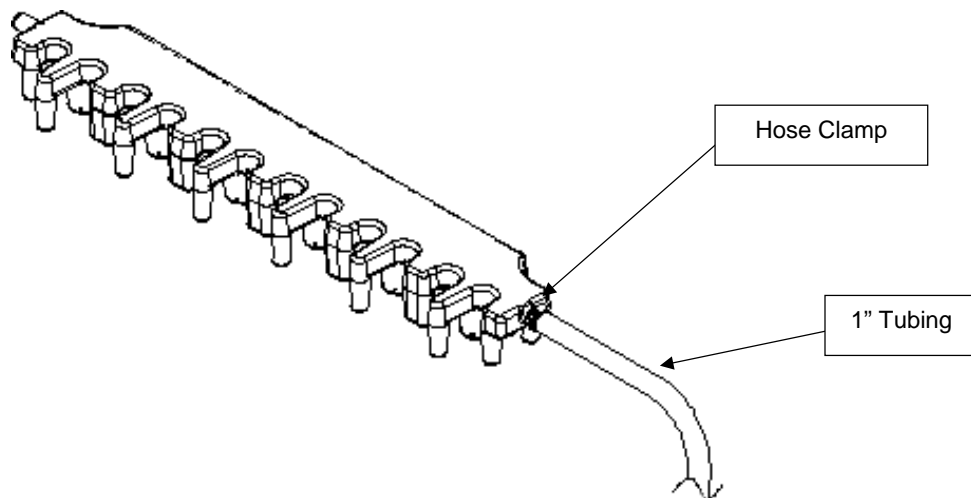

FIGURE 6-3
Water Distributor

7. Troubleshooting

The VT Series ice machine is equipped with a PLC (programmable logic controller) that controls all aspects of the machines operation. One function of the PLC is to shut down the machine when a machine fault occurs. By continuously monitoring the High and Low pressure safety switches, the harvest cycle time, and the oil pressure, the PLC can determine if a problem exists.

Machine Fault Light - if the machine shuts off due to a high pressure fault, low pressure fault, a "long harvest cycle" fault or an oil pressure fault, the machine will not automatically restart. When a "fault" occurs, the PLC sends a signal to the fault indicator light located on the control panel door.

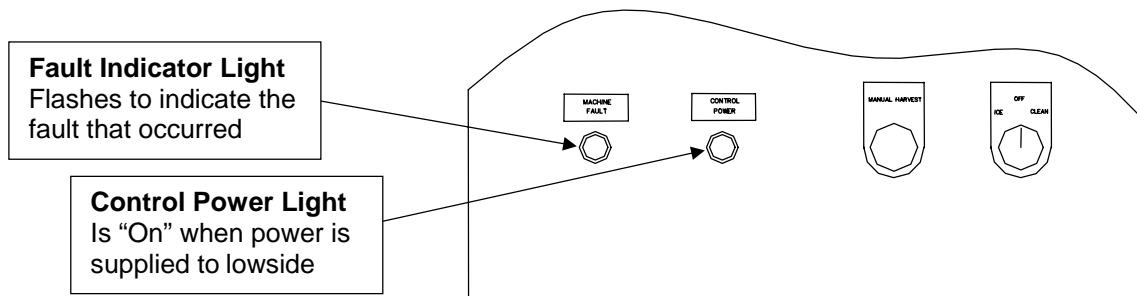

FIGURE 7-1
Lowside Control Panel Front

#	Description	Switch Reset (Auto or Manual)
1	Low Suction Pressure	Auto
2	High Discharge Pressure	Manual
3	Low Oil Pressure	Manual
4	Long Harvest Cycle	N/A
5	Chopper Motor Fault	N/A
6	Pumpdown Fault	Auto
Solid	Power Failure	N/A

TABLE 7-1
PLC Fault Codes

Control Power Light – if the machine is shut off and the “Control Power” light on the lowside unit is not “On”, check the 3A circuit breaker (CB3/CB4) in the lowside control panel. If after resetting the breaker, the control light still does not come on, check the 10A breaker (CB1) in the condensing unit control panel.

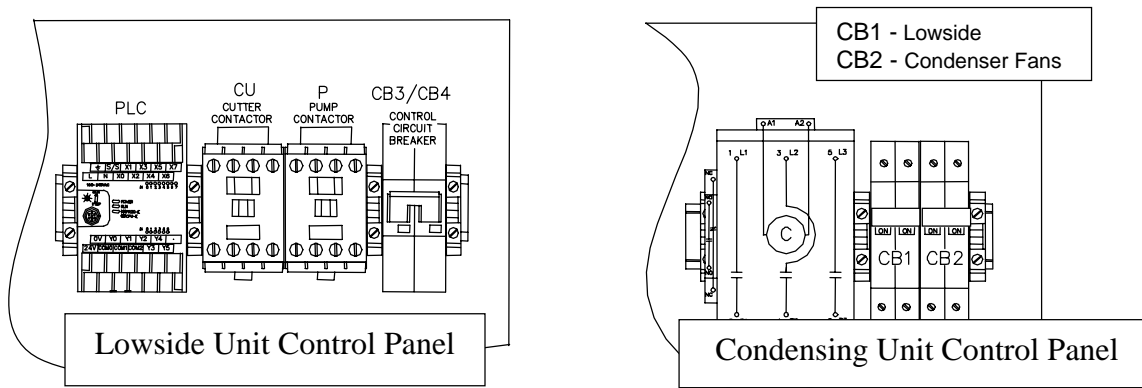

FIGURE 7-2
Control Panel

	#	Description		#	Description
Inputs	0	Current Sensing Relay (chopper)	Outputs	0	Fault Indicator light
	1	"On" Selector Switch/Bin Control		1	Liquid Feed Solenoid (R404A machines only)
	2	HH Pressure Switch		2	Compressor
	3	Manual Harvest (Start) Button		3	N/A
	4	Clean Switch		4	Water Pump
	5	High Pressure Safety Switch		5	Chopper/Hot Gas Valve/Defrost Loop or Suction Stop valve (VT80 & VT100)
	6	Low Pressure Safety Switch			
	7	Oil Safety / Compressor OL (VT80 & VT100)			

TABLE 7-2
PLC Inputs/Outputs

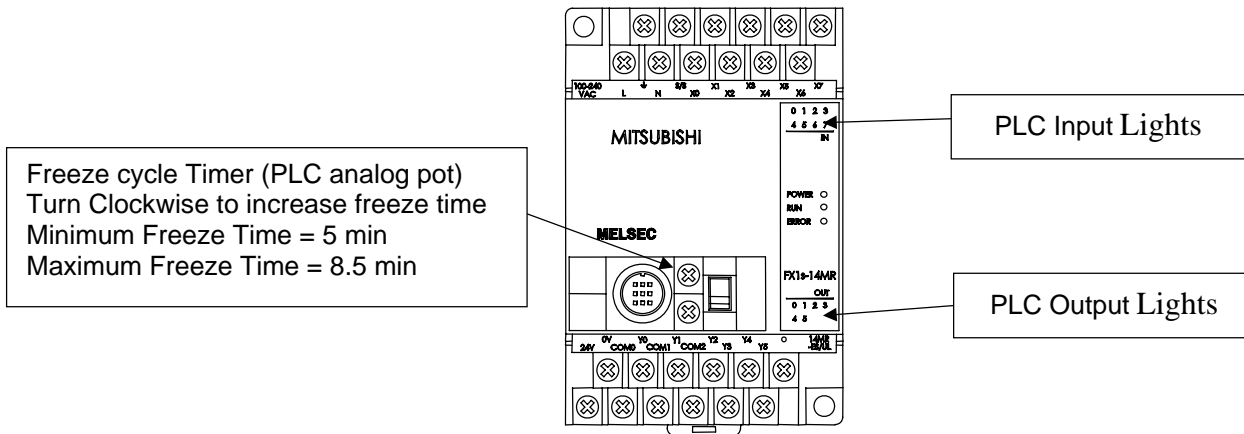

FIGURE 7-3
PLC (FX1S)

Damaged Bin Control Sensor – If the machine is not running and it uses the electronic temperature control to shut the machine off when the bin is full, one of the first things to check is the Bin Control sensor. If the sensor is bad or has been damaged, "EP" will be displayed. See 8-3 for more details.

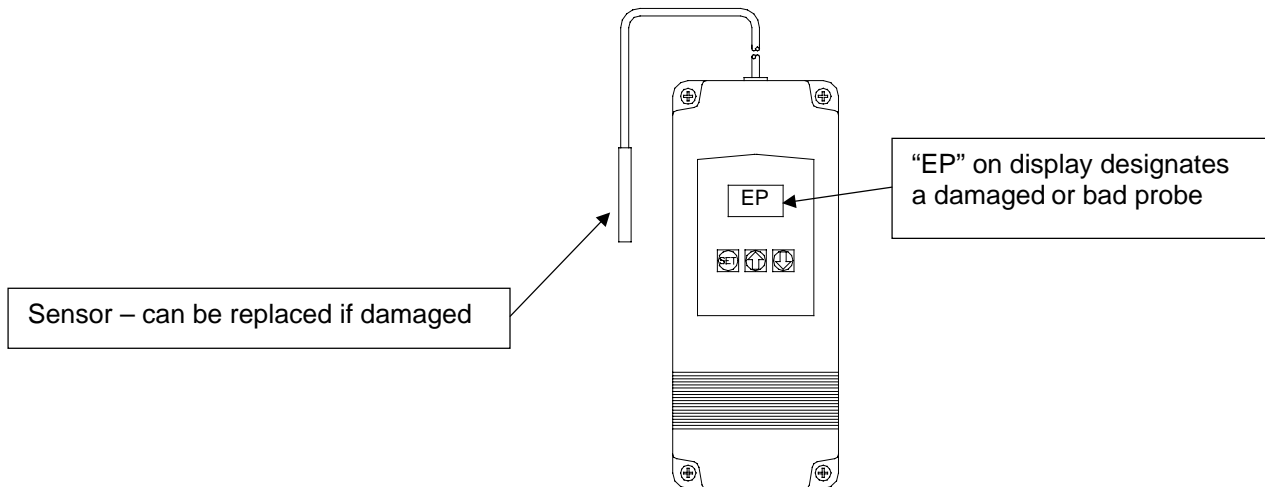

FIGURE 7-3
Electronic Bin Control

MACHINE INOPERATIVE

No Electrical Power: Check main electrical fused disconnect or circuit breaker. If power has been off, crankcase heater should be energized two (2) hours prior to starting.

Note: If no power to the lowside unit, check 10A breaker in condensing unit electrical enclosure.

High Pressure Safety: Reset high pressure control switch. If tripped, install gauges observe operating pressures to determine that compressor discharge pressure is within operating limits. If fans do not come "on", check circuit breaker in condensing unit control panel.

Low Pressure Safety: This switch will automatically reset when pressure comes up to the "cut-in" set point. If tripped, install gauges observe operating pressures to determine that compressor suction pressure is within operating limits. If suction pressure is low, check machine refrigerant charge.

Note: When the machine starts after a power failure or after the machine has cycled off on bin control or the "on/off/clean" selector switch, the PLC do not look at the low pressure switch for 90 seconds.

Compressor Motor Overload Protector (Klixon): Machines are equipped with a compressor protection device that opens in the event compressor temperature or amperage reaches an extreme that could damage compressor. The device automatically resets after compressor has cooled.

(Note: On VT80 & V100 Only). Note: This sensor is in series with the oil pressure safety switch. Fault #3 can be either compressor motor overload or oil pressure.

CAUTION: If machine is off on motor overload protector, control cycle timer and other components will continue to function although the compressor is off. The machine or any of its components can start without warning causing serious injury.

Bin Control Open: Adjust thermostat bin control as required. See page 8-3 for bin control error code.

Faulty Remote Off/On Switch: Replace if necessary.

Compressor Contactor Defective: Check wiring to line contactor to determine that "L" terminals are supplied with power. Check contactor coil for open winding.

Oil Failure Switch: Reset Sentronic oil pressure safety switch. Check compressor oil level. If oil level in sightglass, check oil pressure.

Note: Verify proper operation of crankcase heater. Cold starts can cause oil loss.

Chopper Failure: If the chopper motor fails to come on, the current sensing relay in the chopper motor circuit will detect the absence of motor current and shut the machine off. See Machine "Freeze-Up".

MACHINE “FREEZE-UP”

The following situations may cause machine “freeze-up”:

1. Harvest hold switch is improperly set
2. Improper fan control setting
3. Low head pressure limiting available gas for defrost
4. Dirty, scratched, or dented evaporator surface
5. Chopper motor or motor contactor defective
6. Interruption of electric service
7. Off on low pressure and reset without clearing tubes.
8. Low pressure safety switch improperly adjusted, causing termination prior to harvest.
9. Loss of water pressure.
10. Defective hot gas solenoid valve.
11. TXV not adjusted properly or functioning properly. Ice freezing too far up tube.

Note: If ice is freezing too high (onto the top flange holding the evaporator) the ice may not drop from the evaporator tubing. See page 8-6 for adjusting TXV.

Clearing a “freeze-up can be accomplished by placing “On/Off/Clean” selector switch in the “Clean” position and circulating water over the tubes.

CAUTION: Clearing “freeze-ups” should be done using only water. Use of any foreign objects (example: hammer or screw driver) may damage tube surface. If tube is dented or scratched, ice will not release properly. This will void the evaporator warranty.

ADDITIONAL TROUBLESHOOTING

Low Suction Pressure - Possible causes include:

1. Evaporators froze up
2. Plugged drier
3. Low refrigerant charge
4. Moisture causing freezing @ TXV
5. Low water circulation
6. Faulty TXV
7. Bad hot gas solenoid valve

High Head Pressure - Possible causes include:

1. Plugged condenser
2. Faulty fan motor
3. Faulty fan cycle switch
4. Faulty thermostat at condenser (allowing only one fan to run)
5. Refrigerant overcharge
6. Non condensable present.
7. Electric interruption to condenser (Remote condenser only)

Compressor Oil Pressure Fault - Possible causes include:

1. Faulty oil pressure sensor or module (Sentronic)
2. Clogged oil pump suction screen
3. Low compressor oil
4. Low compressor superheat

Compressor Runs But Condenser Fan Does Not:

1. Faulty fan cycle switch
2. Faulty fan motor
3. Blocked fan blade
4. Electric interruption to condenser (circuit breaker located in condensing unit control panel)

Compressor Will Not Run, Water Pump Runs:

1. Open compressor overload (on VT-40 & VT-60 only)
2. Defective compressor
3. Faulty compressor contactor

Water Pump Will Not Run, Compressor Runs:

1. Faulty pump
2. Electric service interrupted to pump - pump contactor

Pump and Compressor Run with Insufficient Water on the Evaporators:

1. Water system needs cleaning
2. Faulty pump
3. Inadequate water supply
4. Obstructed float assembly
5. Improper float adjustment

Chopper motor Fault:

1. Bad chopper motor
2. Bad chopper motor contactor
3. Machine Froze up

Blank Page

8. Service Operations

PRINCIPLE OF OPERATION

The Vogt® VT Series line of ice making machines from Vogt® Tube Ice®, LLC, combines state-of-the-art technology and efficiency with a reputation for quality and reliability developed over four decades of manufacturing.

In the Vogt® VT Series icemaker, ice is produced on both walls of vertically suspended cylindrical tubes with recirculating water. As ice is produced, makeup water is fed to the water tank via float valve. Freeze time and harvest time are controlled by a Programmable Logic Controller (PLC).

In freeze cycle, the liquid feed valve is “open” (R404A machines only) and the compressor and water pump are “on”. At the end of the Freeze cycle, the PLC initiates the Harvest cycle where the hot gas solenoid valves and chopper motor are energized, and the water pump is turned “off” and liquid feed valve “closed”.

Bin control or remote on/off switch will allow machine to complete a freeze and harvest cycle prior to interrupting operation. For R404A machines, the machine will go thru a Pumpdown before cycling off.

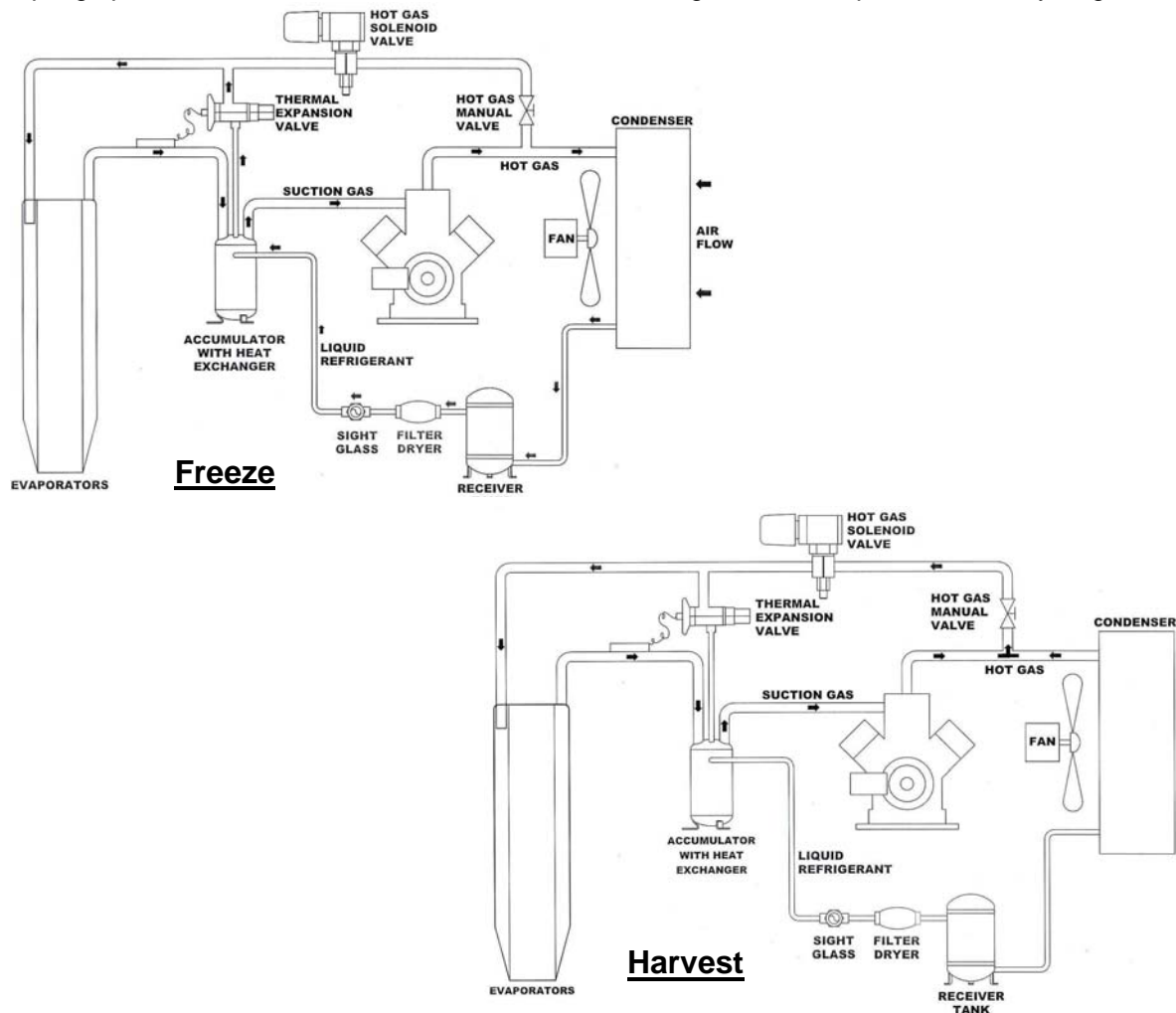

FIGURE 8-1
Piping Schematic

Service Operations

Pressure Switches

High Pressure Safety: 12A2117H01 (Penn) This switch terminates operation of machine when high compressor discharge pressure occurs.

Settings: Cut-Out ("Off") 300 PSIG (R22) / 350 PSIG (R404A). Manual Reset

Low Pressure Safety: 12A2117B08 (Penn) This switch terminates operation of machine when low suction pressure occurs.

Note: When the machine starts after a power failure or after the machine has cycled off on bin control or the "on/off/clean" selector switch, the plc do not look at the low pressure switch for 90 seconds.

Settings: Cut-out ("Off") 10 PSIG (R22 & R404A)

Cut-in ("On") 20 PSIG. (R22 & R404A)

Fan Control Switch: 12A2117F05 (Penn) This switch cycles the condenser fan motors to maintain proper discharge pressure.

Settings: Cut-in ("On") 220 PSIG (R22) / 250 PSIG (R404A)

Cut-out ("Off") 200 PSIG (R22) / 230 PSIG (R404A)

Harvest Hold Switch: 12A2117B03 (Penn) This switch stops harvest timer (holds machine in harvest) until the suction pressure comes up to the switch sets set point. Note: In low ambient conditions, the harvest time may be increased by raising the switch Cut-out setting to 70-75 psig.

Settings: Cut-In ("On") 45 PSIG (R22) / 60 PSIG (R404A)

Cut-out ("Off") 65 PSIG (R22) / 80 PSIG (R404A)

Oil Failure Switch: 12A2117A05 (Copeland Sentronic) This device monitors the compressor oil pump differential pressure. If oil pressure drops below 7-9 psig for a period of two minutes, the Sentronic module will open the control circuit contact and shut the machine off.

Factory set @ 7-9 psig (Manual reset)

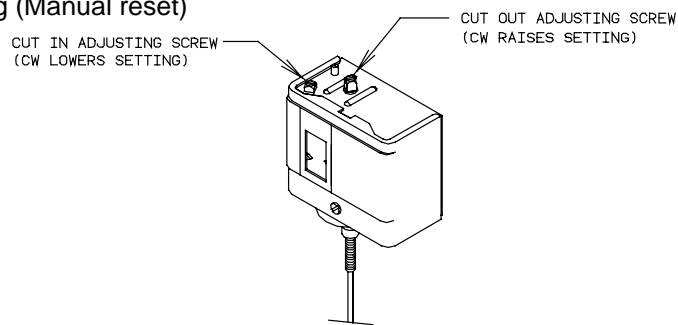

FIGURE 8-2

Condenser Fan Control Switch, Low Pressure Safety & Harvest Hold Switch

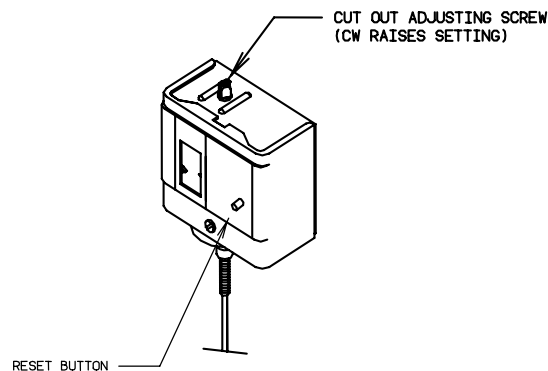

FIGURE 8-3

High Pressure Safety Switch

Bin Control (Ranco Electronic Temperature Control)

With the Ranco electronic temperature control the ice must come in contact with the sensor to shut the machine off. The sensor should be installed in the bin using the standard bin thermostat mounting bracket. Three quarters of the sensor (black part) should hang below the bottom of the bracket.

Programming the Sensor

- 1) Press the “SET” button to enter the sensors setup mode
- 2) Select between “C”- Celsius and “F” - Fahrenheit
Use the up ▲ or down ▼ key to select “F”
- 3) Press the “SET” button to set the Set point (S1 will be blinking)
Use the up ▲ or down ▼ key to set the temperature at 38°F
- 4) Press the “SET” button to set the Differential (DIF 1 will be blinking)
Use the up ▲ or down ▼ key to set the differential at 2°F
- 5) Select between “C1”- Cooling mode and “H1” - Heating mode
Use the up ▲ or down ▼ key to select “C1”

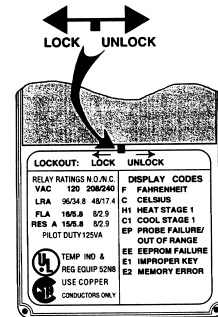

Machine will shut off when temperature drops to 38°F and come on when temperature reaches 40°F.

Note: The sensor will automatically exit the programming mode if no keys are depressed for a period of thirty seconds. Any settings that have been input to the control will be accepted at that point.

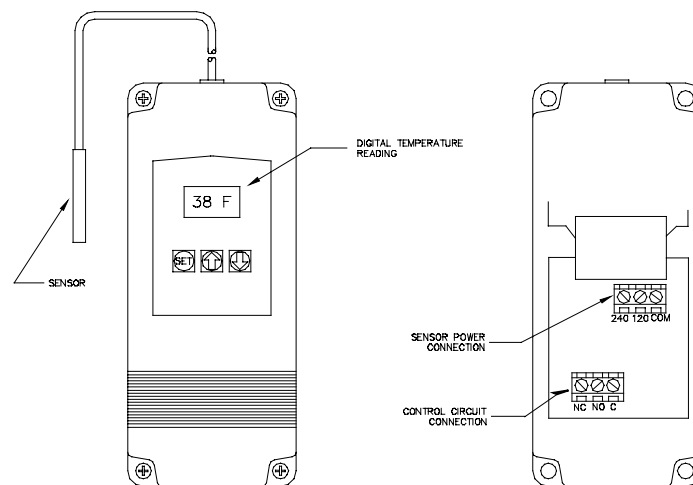

FIGURE 8-4
Electronic Temperature Control - Part # 12A 2117G09

Error Messages

- E1** – Appears when either the up ▲ or down ▼ key is pressed when not in the programming mode.
To correct: If the E1 message appears even when no keys are being pressed, replace the control.
- E2** – Appears if the control settings are not properly stored in memory.
To correct: Check all settings and correct if necessary.
- EP** – Appears when the probe is open, shorted or sensing a temperature that is out of range.
To correct: Check to see if the sensed temperature is out of range. If the sensor is subject to a known ambient temperature between -30°F and 220°F, and displays the EP code, replace the damaged probe.
- EE** – Appears if the EEPROM data has been corrupted.
To correct: This condition cannot be field repaired. Replace the control.

Note: Electronic Temperature Control #: 12A2117G09 / Replacement Sensor #: 12A2117G0901

PLC (Programmable Logic Controller). The VT-Series ice machine is controlled by a PLC (Programmable Logic Controller). The PLC controls the sequence of events and monitors the ice machine functions. The operational sequences of the VT-Series ice machine can be described best as a series of six different modes. Each mode identifies and defines a sequence of events that occur while in that mode and thereby cause it to move to the next mode. Only one mode is active at a time.

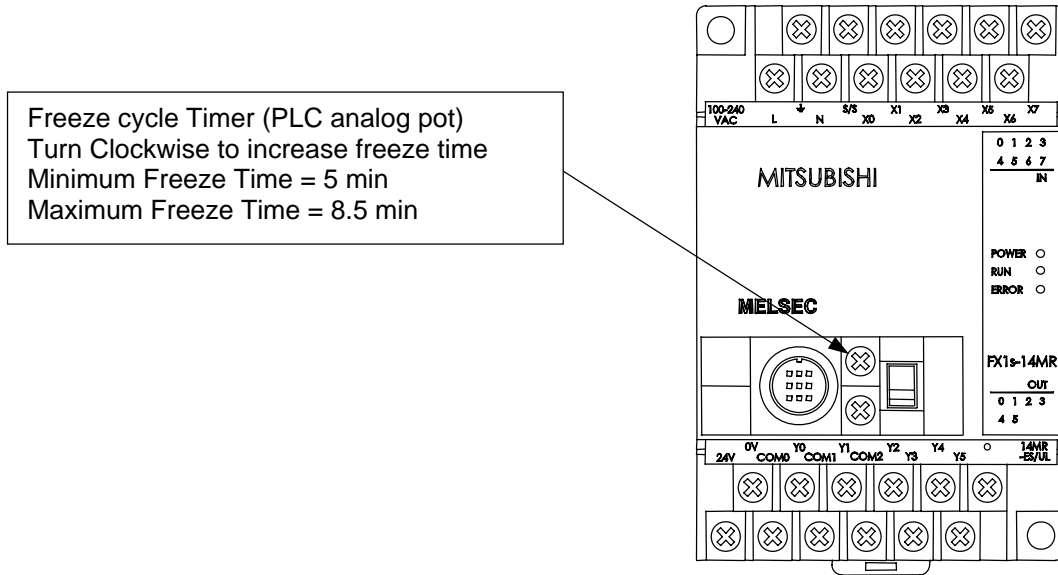

FIGURE 8-5
PLC (Programmable Logic Controller)

	#	Description		#	Description
Inputs	0	Current Sensing Relay (chopper)	Outputs	0	Fault Indicator light
	1	“On” Selector Switch/Bin Control		1	Liquid Feed Solenoid (R404A machines only)
	2	HH Pressure Switch		2	Compressor
	3	Manual Harvest (Start) Button		3	N/A
	4	Clean Switch		4	Water Pump
	5	High Pressure Safety Switch	5	Chopper/Hot Gas Valve/Defrost Loop valve or Suction Stop Valve (VT80 & VT100)	
	6	Low Pressure Safety Switch			
	7	Oil Pressure Safety Switch			

TABLE 8-1
PLC Inputs/Outputs

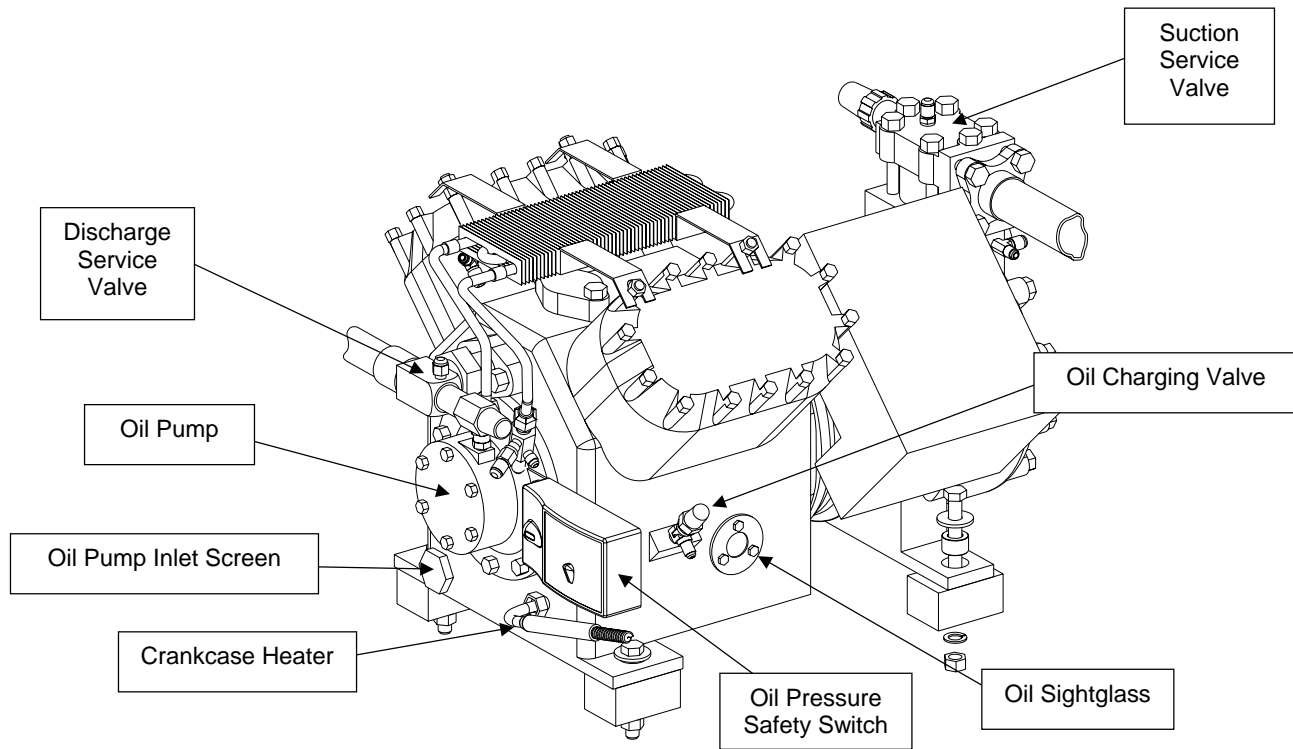
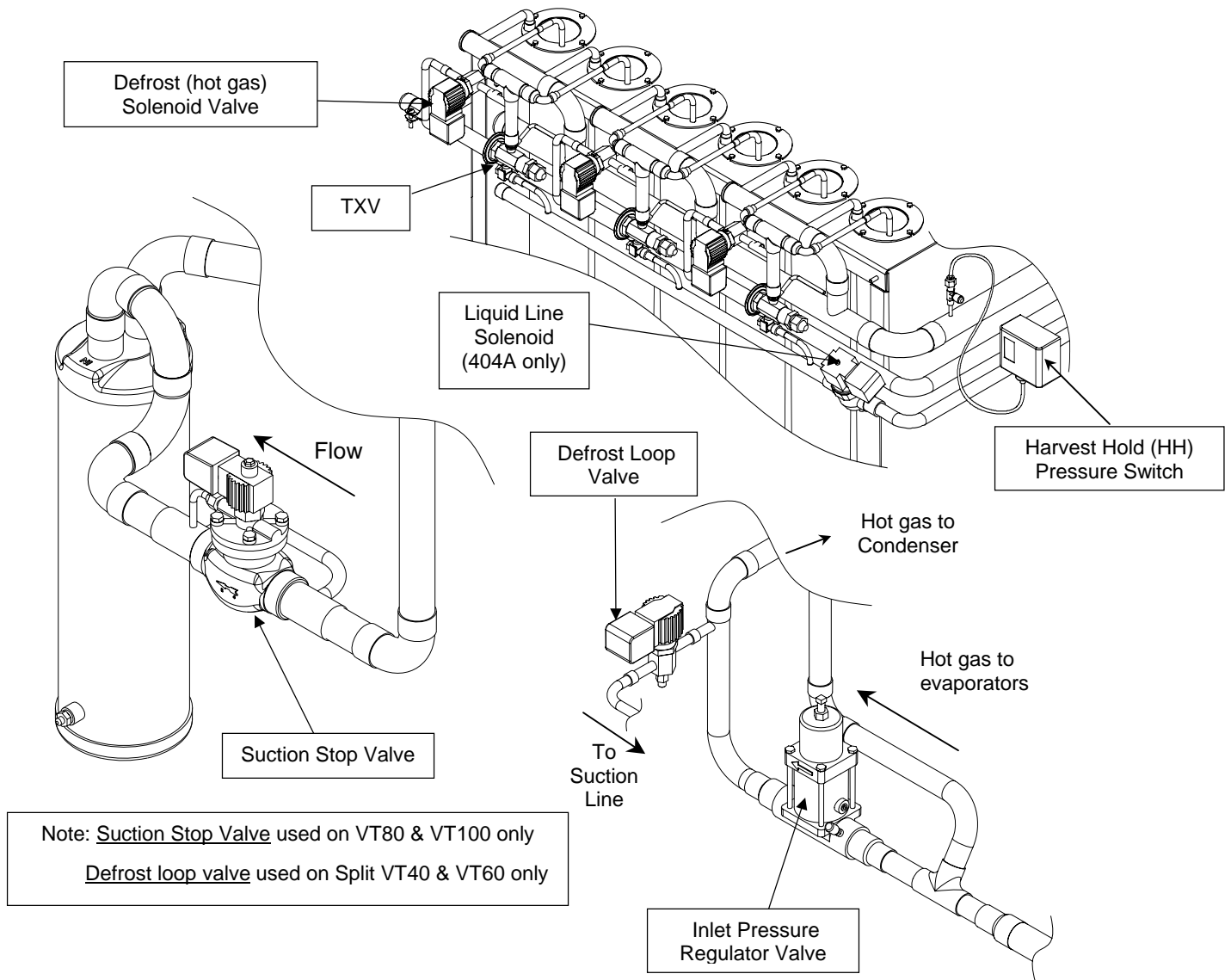

FIGURE 8-6
Copeland Discus Compressor (10HP Shown)

Description		Refrigerant	Vogt #	Copeland #
Compressor	VT-40 (5 1/2HP)	R22	12A2110A117	3DB3F33K0-TFC-100
		R404A	12A2110A130	3DB3F33KE-TFC-100
	VT-60 (7 HP)	R22	12A2110A110	3DS3F46K0-TFC-100
		R404A	12A2110A131	3DS3F46KE-TFC-100
	VT-80 (10 HP)	R22	12A2110A122	4DL3F63K0-TSK-253
		R404A	12A2110A128	4DL3F63KE-TSK-253
VT100 (12 1/2 HP)	R22	12A2110A125	4DT3F76K0-TSK-253	
	R404A	12A2110A129	4DT3F76KE-TSK-253	
Crankcase Heater	100 W (insert type)	R22/R404A	12A7509E12	518-0028-01
Oil Pressure safety switch	Sentronic		12A2117A05	585-1066-02

TABLE 8-2
Compressor / Compressor Parts

8-6 Service Operations



Description		Vogt #	Manufacture	
Defrost Solenoid Valve (Hot gas valve)	1/2" Solenoid valve	12A4200A406	Sporlan	
	Defrost Loop Valve (Split VT40 & VT60)	1/2" (N.C.) Rebuild Kit	12A4199V53	Sporlan
		Coil	12A2105C16	Sporlan
Suction Stop Valve - N.O. (VT80 & VT100)	1 5/8" Solenoid valve	12A4200A1104	Sporlan	
	1 5/8" (N.O.) Rebuild Kit	12A4199V47	Sporlan	
	Coil	12A2105C04	Sporlan	
Liquid Line Solenoid Valve (R404A machines only)	5/8" Extended End (VT40)	12A4200A0504	Sporlan	
	7/8" Standard length (VT60, 80 & 100)	12A4200A0707	Sporlan	
	5/8" (N.C.) Rebuild Kit	12A4199V38	Sporlan	
	7/8" (N.C.) Rebuild Kit	12A4199V39	Sporlan	
Inlet Pressure Regulator Valve	1 1/8" Regulator valve	12A4200N0903	Parker	
TXV	R22 Machines	12A4200C0305	Sporlan	
	R404A Machines	VT40, 60 & 80	12A4200C0320	Sporlan
		VT100	12A4200C0321	Sporlan

**TABLE 8-3
TXV, Regulator Valve & Solenoid Valves**

Adjusting TXV: Ice should start forming on the evaporator tubes approximately two inches from the top flange. Freezing too high on the evaporator may cause ice to hang up on tubes and not release properly. To lower ice level, the TXV can be closed by running the stem in. Do this by turning the TXV stem clockwise as shown below. (looking up at the valve stem)

Note: Close TXV ¼ turn at a time. Observe several cycles before making further changes.

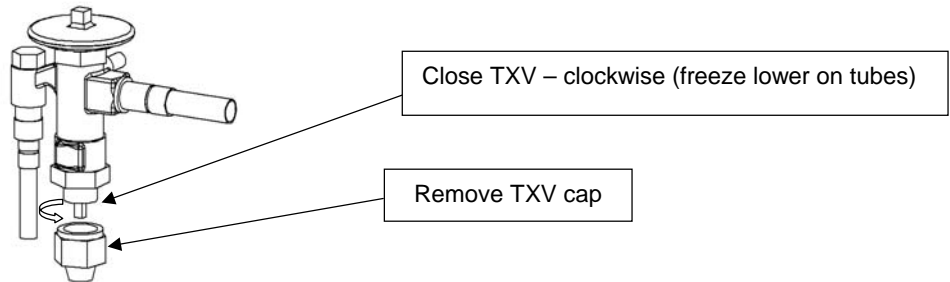

If ice is not freezing high enough on the evaporator tubes, the TXV can be opened by backing the stem out. Do this by turning the TXV stem counter-clockwise. (looking up at the valve stem)

Note: Check expansion valve inlet strainer before opening valve. Clean strainer if necessary. Open TXV ¼ turn at a time. Observe several cycles before making further changes.

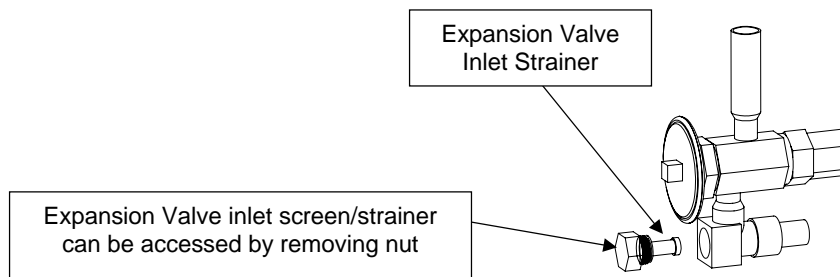

FIGURE 8-7
Adjusting TXV

Inlet Pressure Regulator: This regulator valve is used on the split VT40, split VT60, VT80 and VT100. The purpose of this valve is to maintain head pressure during the harvest cycle. (Set point = 160-170 psig)

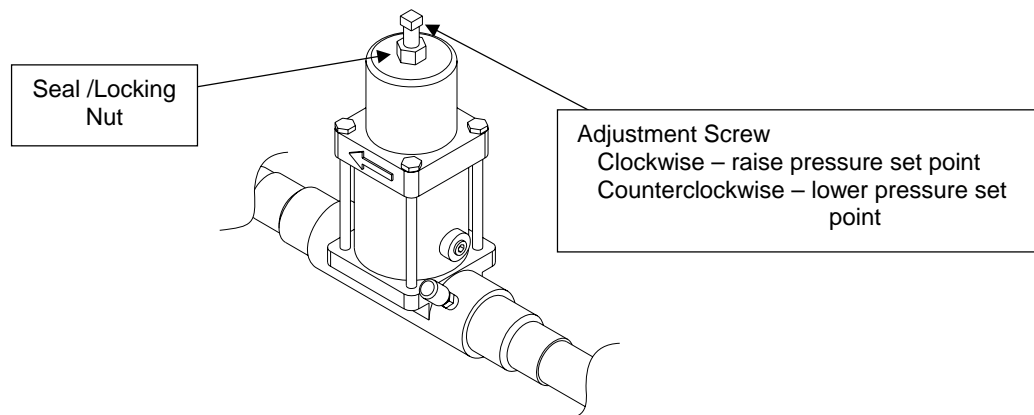

FIGURE 8-8
Inlet Pressure Regulator

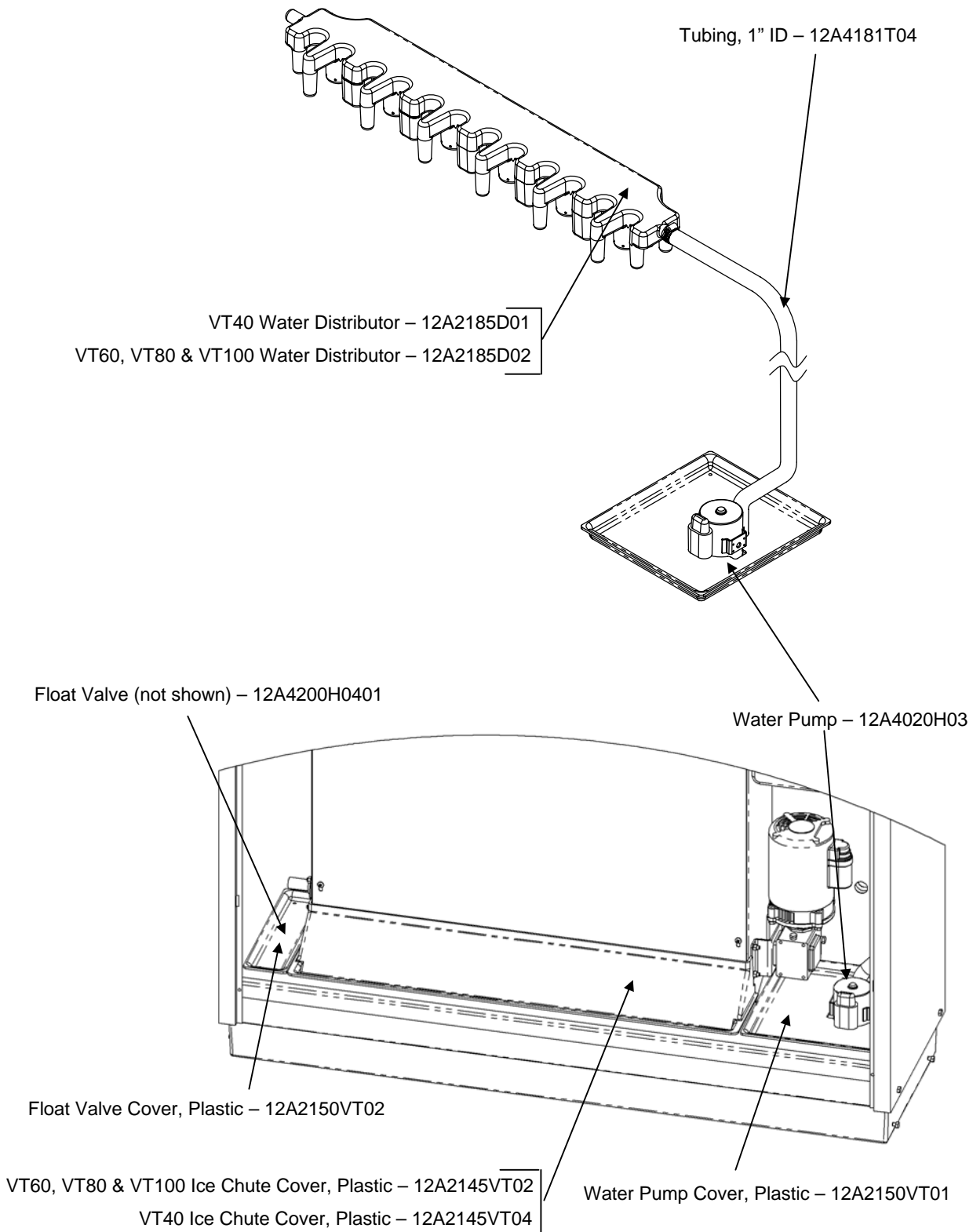
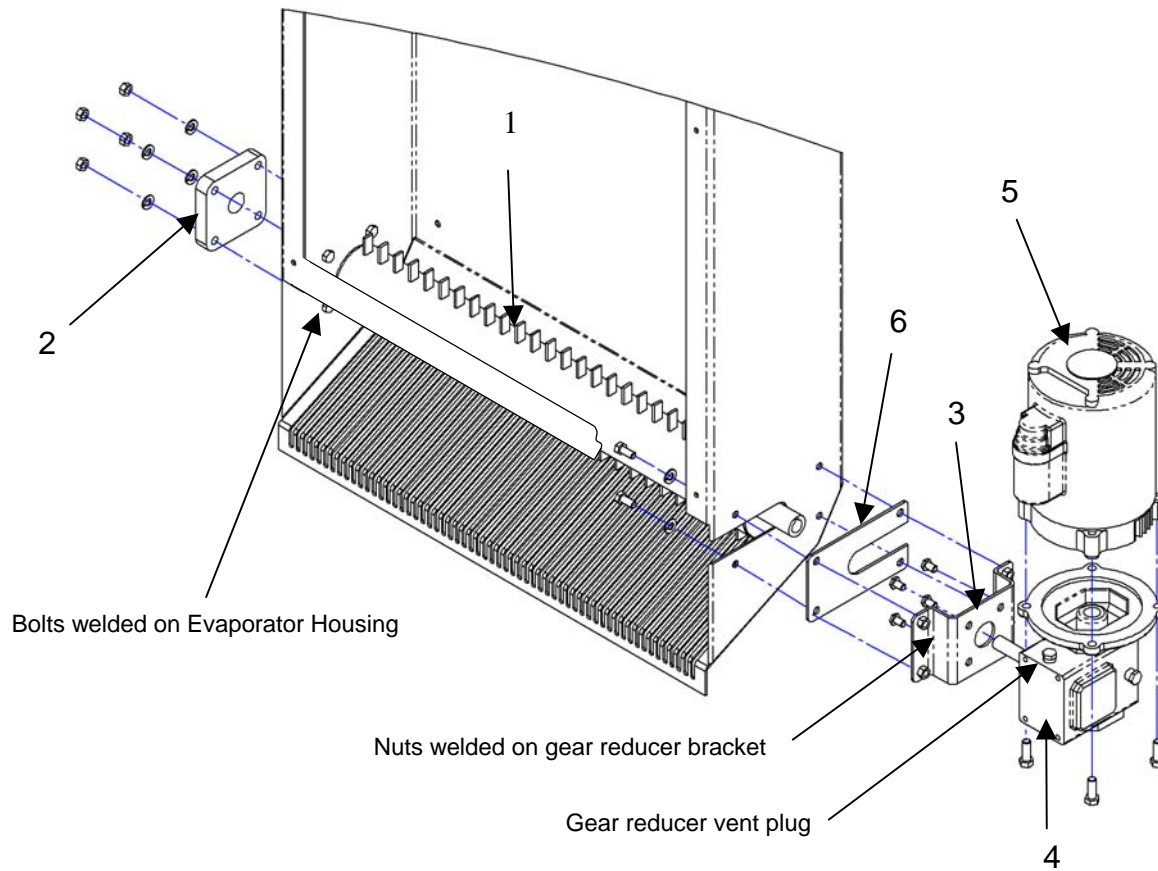
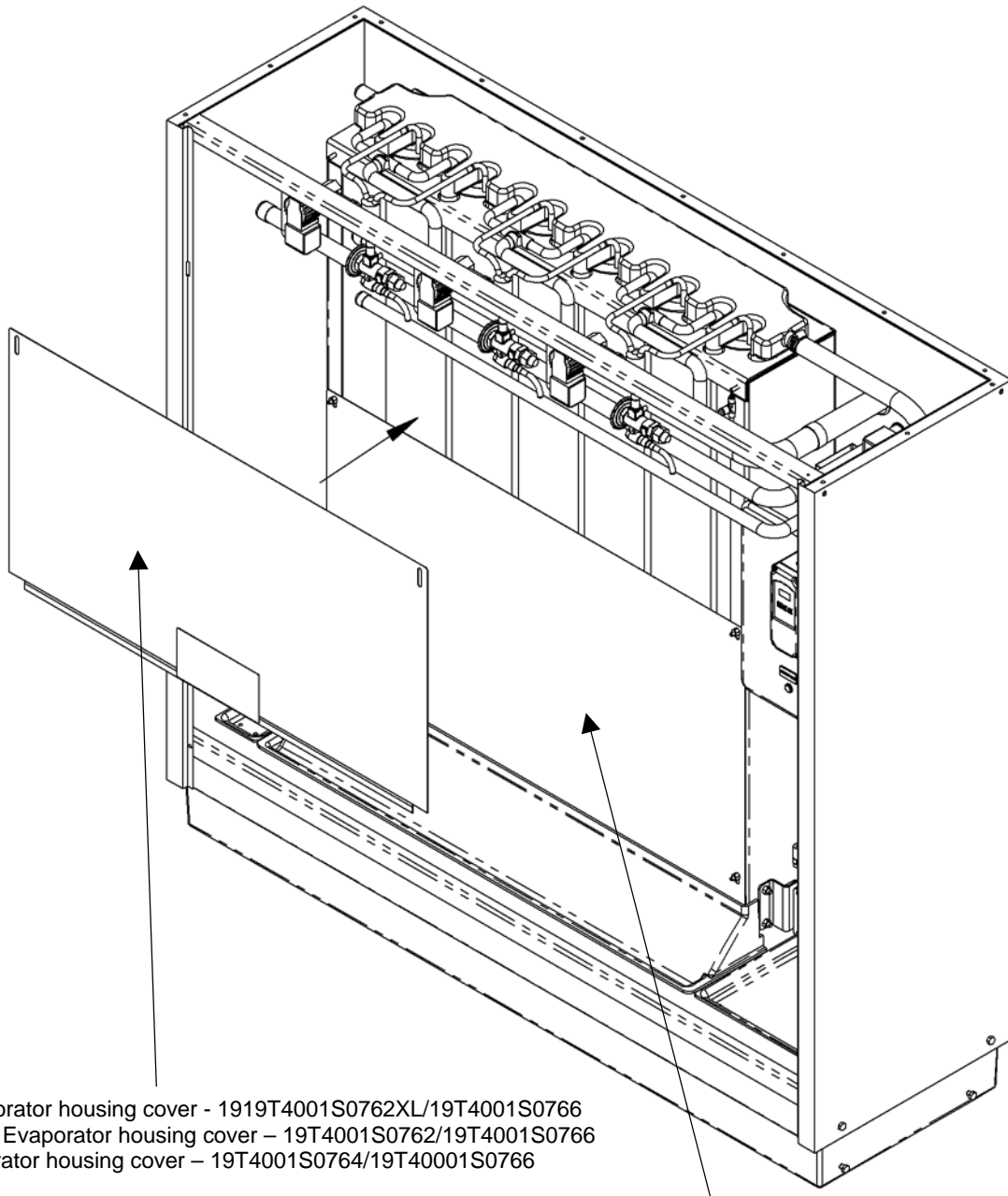

FIGURE 8-9
Water Tank Parts



	Description	Vogt #
1	Chopper assembly	19T2161C03 (VT60, VT80 &VT100) 19T2161C04 (VT40)
2	Bearing, Nylon/Stainless Ball Bearings	12A2020M19
3	Bracket, for Gear Reducer	19T4001S0740
4	Gear Reducer, 5:1	12A4030R14
5	Motor, ½ HP, 3600 RPM, 56C Face, 208-230V, 1 Phase, 50/60Hz	12A2900M0511
6	Plate, UHMW, for Gear Reducer Bracket	19T2150VT01

FIGURE 8-10
Chopper Assembly



VT100 Upper Evaporator housing cover - 1919T4001S0762XL/19T4001S0766
VT60 / VT80 Upper Evaporator housing cover - 19T4001S0762/19T4001S0766
VT40 Upper Evaporator housing cover - 19T4001S0764/19T4001S0766

VT60 / VT80 / VT100 Lower Evaporator housing cover - 19T4001S0763
VT40 Lower Evaporator housing cover - 19T4001S0765

!!!! CAUTION !!!!
Never Operate Machine with Lower Evaporator Housing Cover Removed. Disconnect Power to machine before removing lower evaporator cover.

FIGURE 8-11
Evaporator Covers

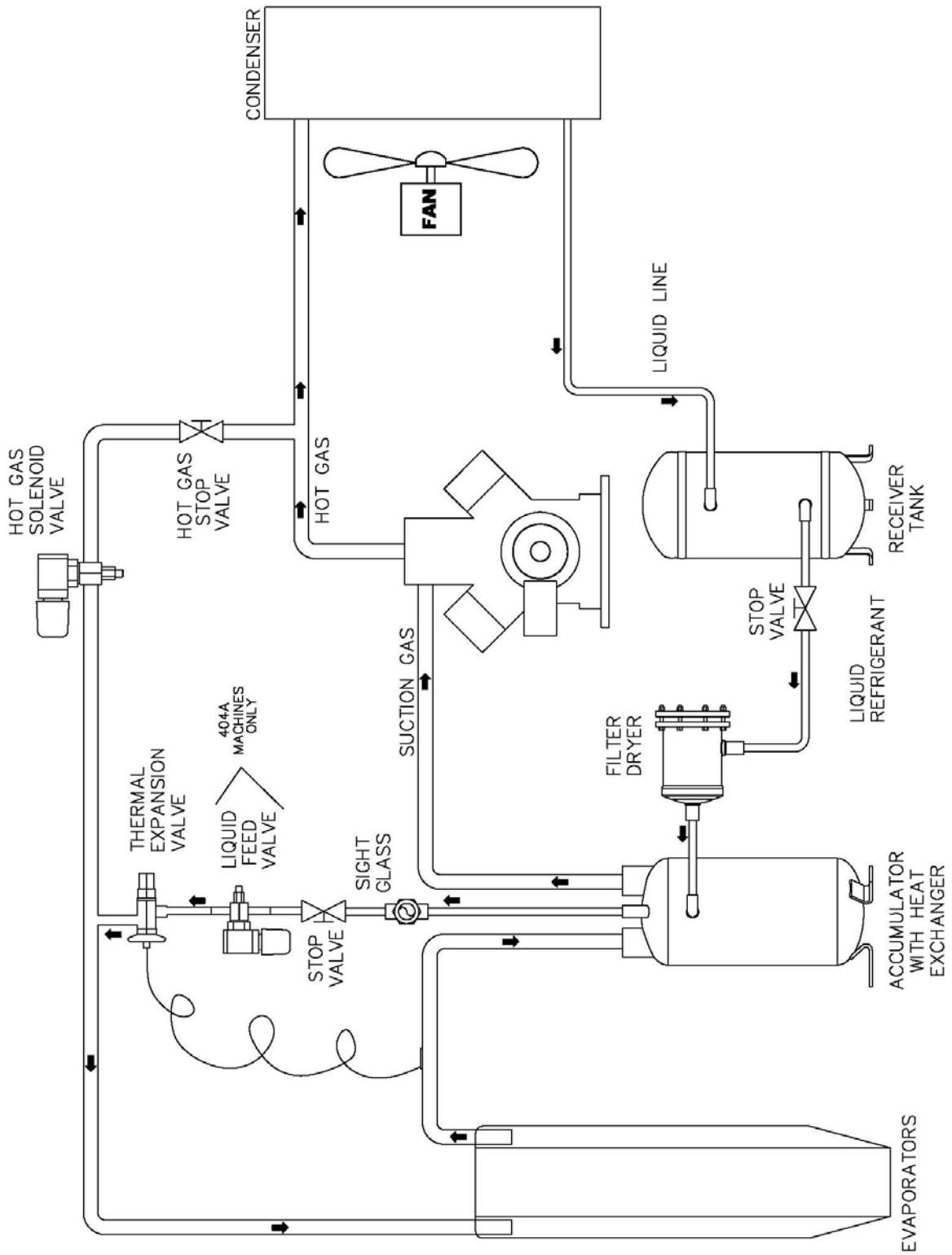

FIGURE 8-12
Freeze Cycle Schematic
Skid mounted (Package VT40 & VT60)

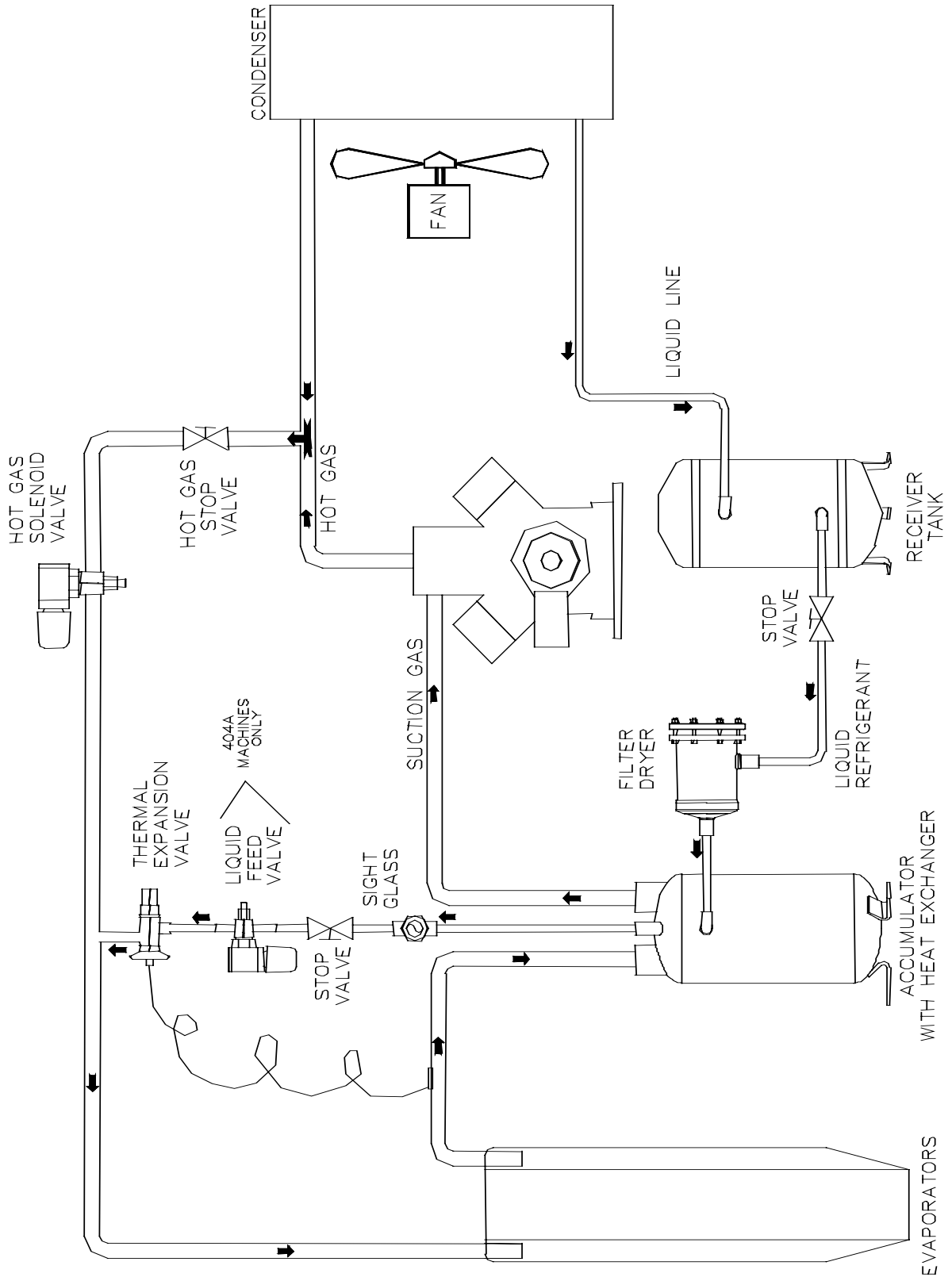

FIGURE 8-13
Harvest Cycle Schematic
Skid mounted (Package VT40 & VT60)

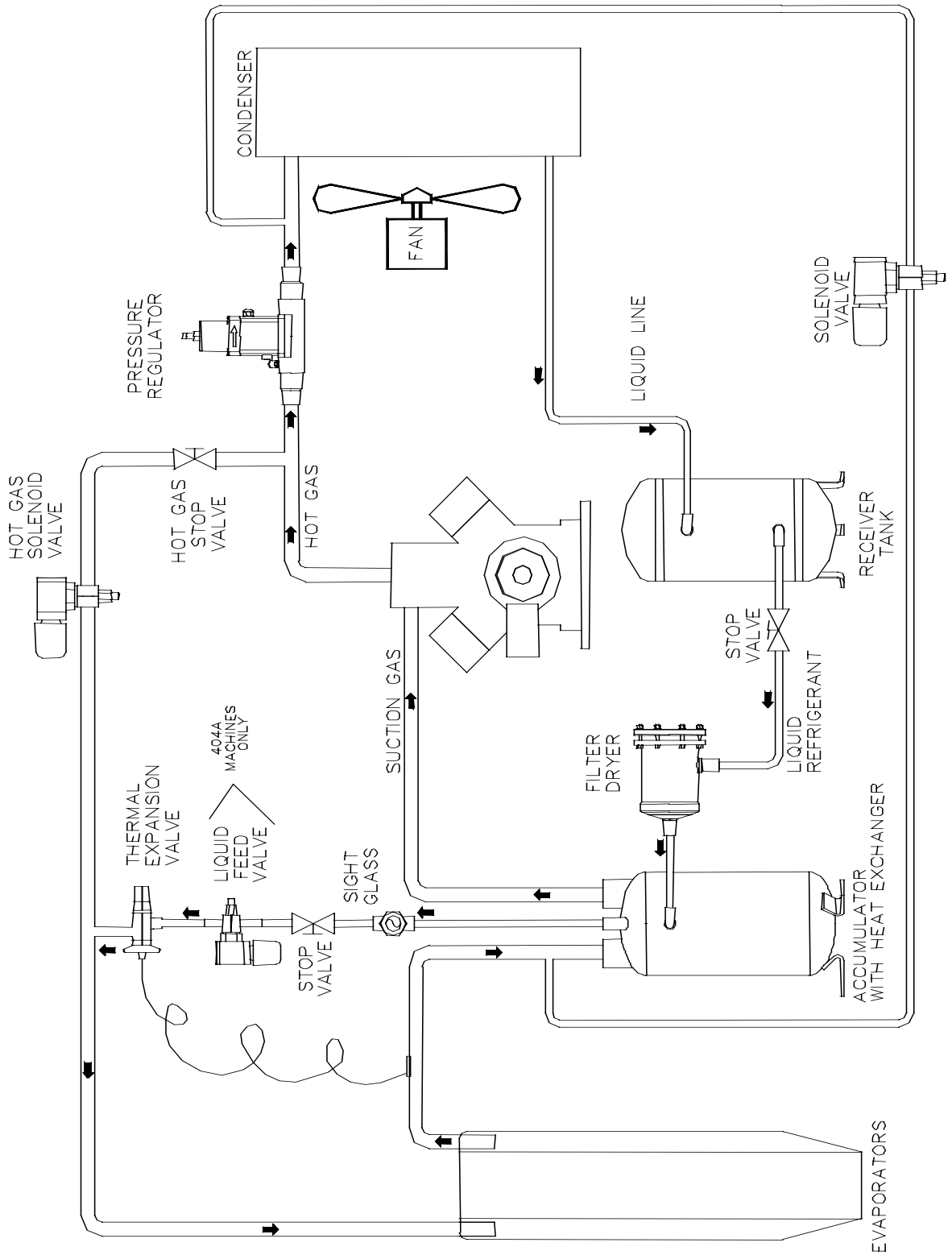

FIGURE 8-14
Freeze Cycle Schematic (w/Defrost Loop Valve)
Split System (VT40 & VT60)

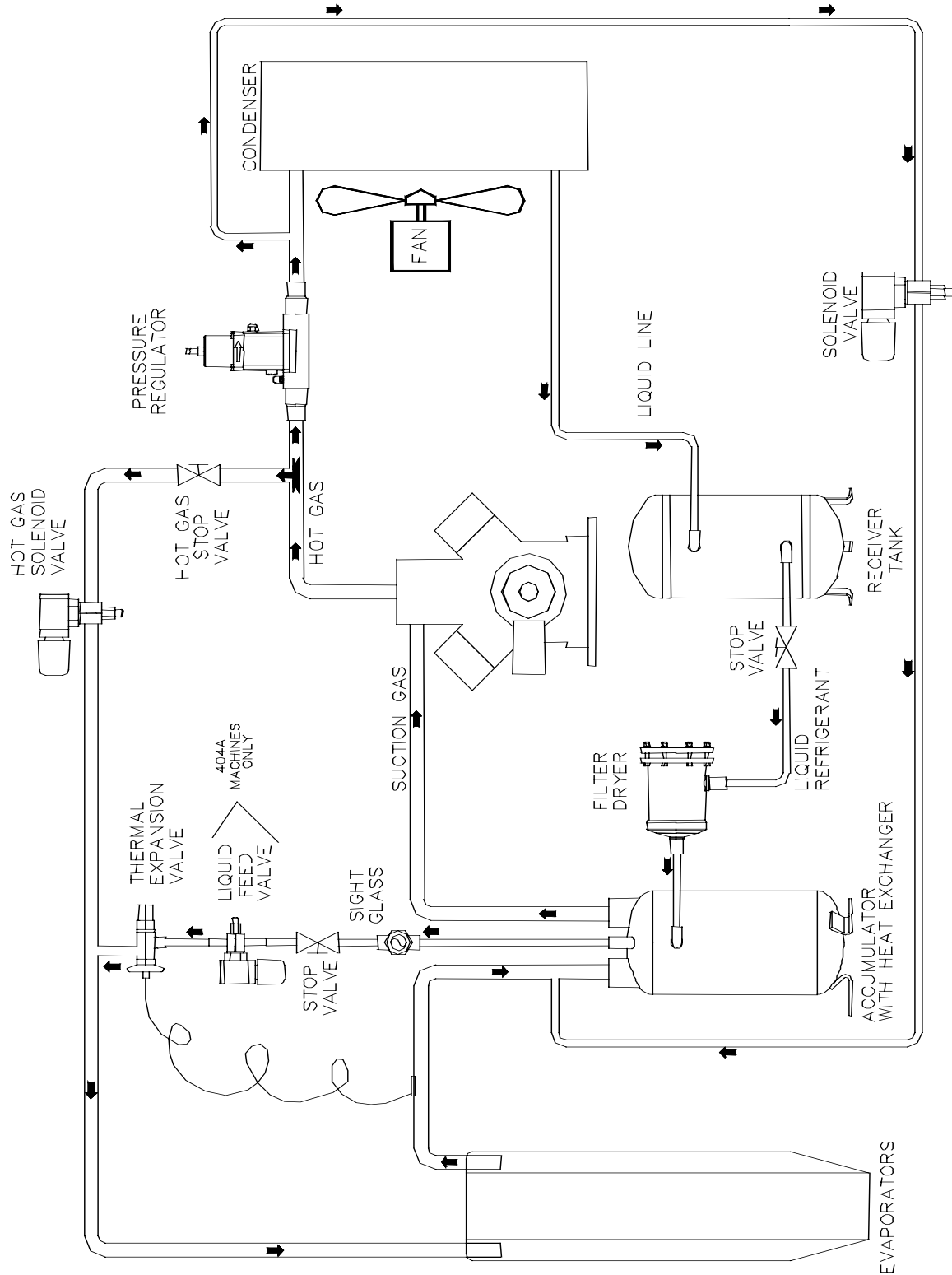

FIGURE 8-15
Harvest Cycle Schematic (w/Defrost Loop Valve)
Split System (VT40 & VT60)

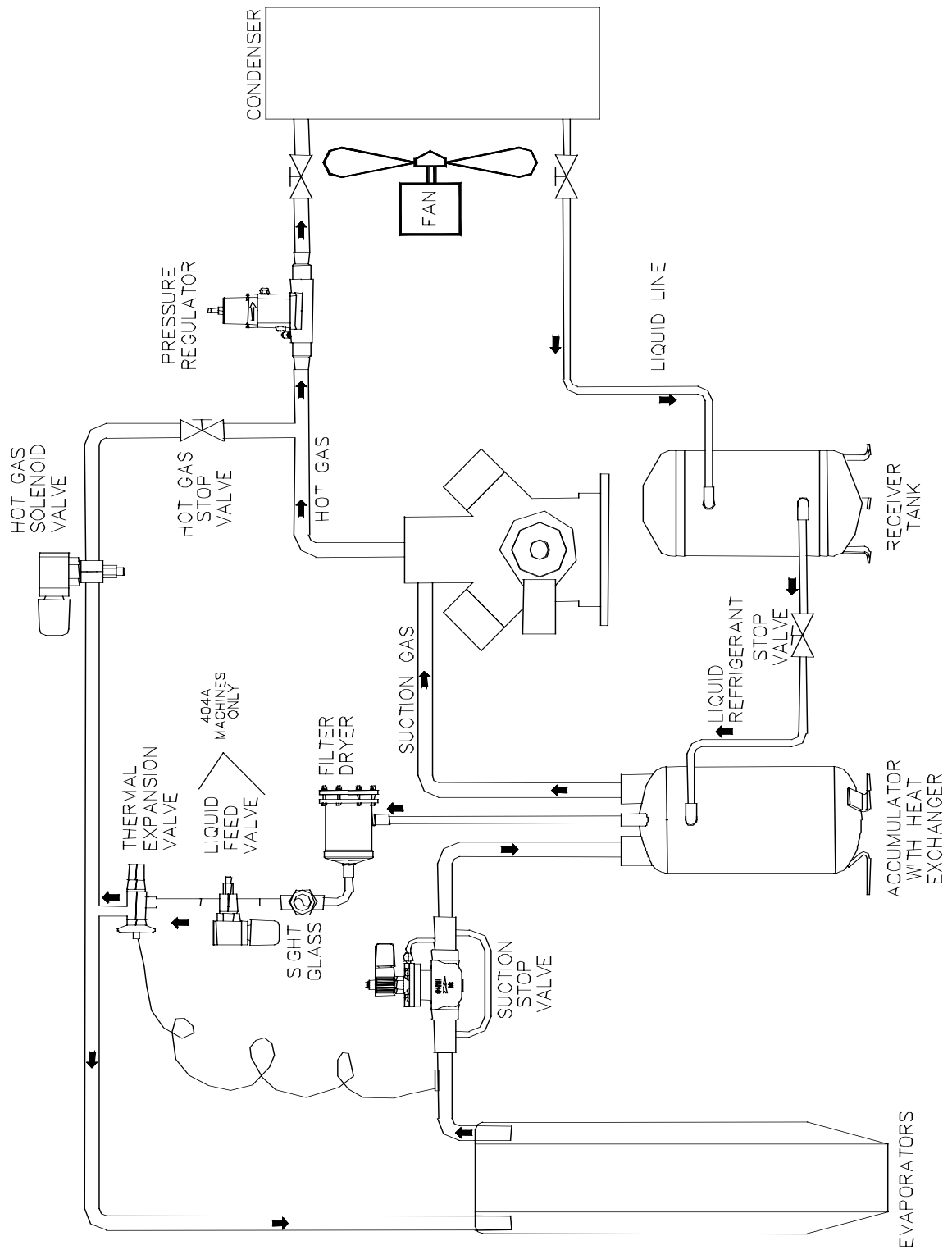

FIGURE 8-16
Freeze Cycle Schematic (w/Suction Stop Valve)
(VT80 & VT100)

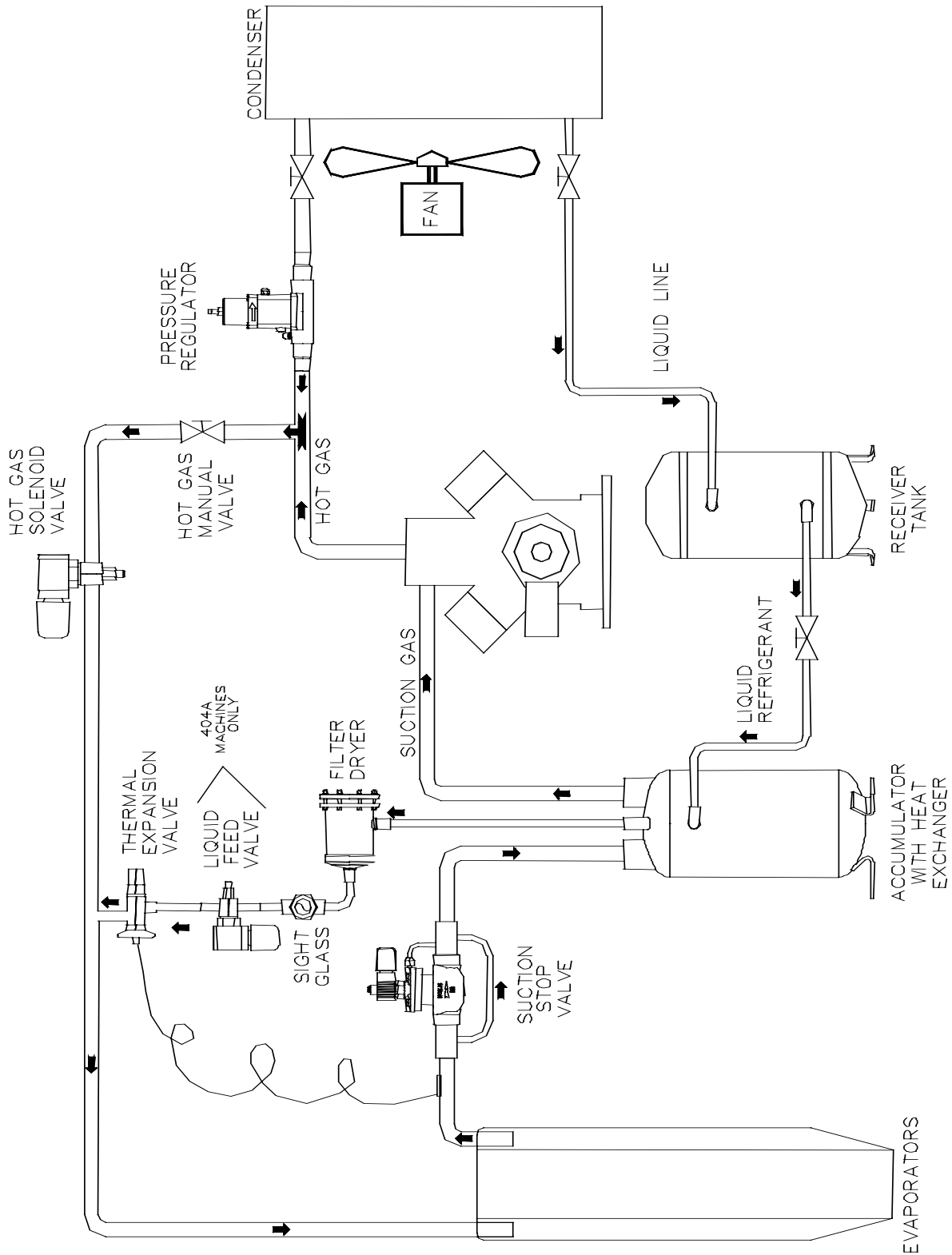

FIGURE 8-17
Harvest Cycle Schematic (w/Suction Stop Valve)
(VT80 & VT100)

Replacement Parts List

Control Panel Components (Low-Side)

Part Number	Req'd	Description
12A2117G09	1	ELECTRONIC BIN THERMOSTAT
12A2117G0901	1	ELECTRONIC THERMOSTAT PROBE
12A7500E61	1	A/B SELECTOR SWITCH, 3 POSITION <i>SS, Ice-Clean-Off Selector Switch</i>
12A7500E73	1	CONTACT BLOCK/MOUNTING LATCH, 2-NO <i>For Ice-Clean-Off Switch</i>
12A7500E56	1	A/B PUSH BUTTON SWITCH (GREEN) <i>PB1-Manual Harvest/Start Switch</i>
12A7500E75	1	CONTACT BLOCK/MOUNTING LATCH, 1-NO <i>For Manual Harvest/Start Switch</i>
12A7536M01	1	PROGRAMMABLE CONTROLLER (PLC)
12A7516E23	2	A/B CONTACTOR, 9-AMP, 3-POLE, 208/240V W/1-NO AUX <i>Cutter or Pump Contactor (CU or P)</i>
12A7515E21	1	CONTROL CIRCUIT BREAKER, 3 AMP, 2-POLE <i>CB3/CB4</i>
12A2117B03	1	THAWING GAS PRESSURE SWITCH <i>HH-Harvest Hold Pressure Switch</i>
12A7520E33	1	INDICATOR LIGHT, 250V RED LENSE <i>1LT-Fault Indicator Light</i>
12A7520E34		INDICATOR LIGHT, 250V AMBER LENSE <i>2LT-Control Power Indicator Light</i>
12A7537S07	1	CURRENT SENSING RELAY

Control Panel Components (Condensing Unit)

12A7516E29	1	A/B CONTACTOR, 43-AMP, 3-POLE, 208/240V W/1-NO AUX <i>C-Compressor Motor Contactor for VT40</i>
12A7516E30	1	A/B CONTACTOR, 72AMP, 3-POLE, 208/240V COIL <i>C-Compressor Motor Contactor for VT60, VT80 & VT100</i>
12A7518E30	1	A/B AUX. CONTACT, 3A, 1 NO/1 NC, (SIDE MOUNT) <i>Auxiliary Contact for Compressor Contactor, VT60, VT80 & VT100</i>
12A7515E18	1	PUMP/CUTTER MOTOR CIRCUIT BREAKER, 2-POLE, 10 AMP <i>CB1-Control Circuit (Low-Side)</i>
12A7515E19	1	CONDENSER FAN CIRCUIT BREAKER, 2-POLE, 15 AMP <i>CB2-Control Circuit (Condensing Unit)</i>
12A2117A05	1	SENTRONIC OIL PRESSURE SAFETY CONTROL
12A2117B08	1	LOW PRESSURE CONTROL 20"-100#, 1/4"SAE, 36" CAP TUBE
12A2117H01	1	HIGH PRESSURE CONTROL, 50-450#, 1/4"SAE, 36" CAP TUBE
12A2117F05	1	CONDENSER FAN CONTROL SWITCH
12A2117G09	1	ELECTRONIC BIN THERMOSTAT – Remote condenser for VT80 & VT100 only <i>(Condenser Fan Cold Weather Thermostat)</i>

Chopper Assembly

19T2161C03	1	CHOPPER ASSEMBLY FOR VT60, VT80 & VT100 (B-SERIES)
19T2161C04	1	CHOPPER ASSEMBLY FOR VT40 (B-SERIES)
12A2020M19	1	BEARING, NYLON/STAINLESS STEEL BALL BEARING 1" BORE
12A4030R14	1	GEAR REDUCER, GROVE 5:1 RATIO
12A2900M0511	1	CHOPPER MOTOR, 1/2 HP, 3600 RPM, 115/230V-1PHASE

Circulating Water

12A4200H0401	1	FLOAT VALVE, ½" ROBERTS #RM214
12A4020H03	1	PUMP, HARTELL, 1/12HP, 208-230V, 50/60HZ <i>Replaces Beckett, Pump #12A4020B01</i>
12A4181T04	6	TUBING, TYGON B-44-3, 1-1/4" OD x 1" ID <i>Circulating Water Tubing (Priced per Ft.)</i>
12A2185D01	1	WATER DISTRIBUTOR FOR VT40
12A2185D02	1	WATER DISTRIBUTOR FOR VT60, VT80 & VT100
12A2150VT01	1	WATER PUMP COVER FOR VT (B-SERIES)
12A2150VT02	1	WATER FLOAT VALVE COVER FOR VT (B-SERIES)
12A2145VT02	1	ICE CHUTE COVER FOR VT60, VT80 & VT100 (B-SERIES)
12A2145VT04	1	ICE CHUTE COVER FOR VT40 (B-SERIES)

Liquid Line

<u>Part Number</u>	<u>Req'd</u>	<u>Description</u>
12A4200C0305	2 or 3	R22 - EXPANSION VALVE, SPORLAN 2 for VT40, 3 for VT60, VT80 & VT100
12A4200C0320	2 or 3	R404A - EXPANSION VALVE, SPORLAN 2 for VT40, 3 for VT60 & VT80
12A4200C0321	3	R404A - EXPANSION VALVE, SPORLAN VT100
12A4200A0504	1	SOLENOID VALVE, 5/8" ODC, Normally Closed, Sporlan, 208/230V COIL (Liquid Feed) VT40 (R404A only)
12A4199V38		REPAIR KIT FOR 5/8" SPORLAN Solenoid Valve, B14S2 OR E10S2
12A4200A0707	1	SOLENOID VALVE, 7/8" ODC, Normally Closed, Sporlan, 208/230V COIL (Liquid Feed) VT60, VT80 & VT100 (R404A only)
12A4199V39		REPAIR KIT FOR 7/8" SPORLAN Solenoid Valve, B25S2 OR E25S2
12A2625S02	1	LIQUID INDICATOR, 7/8" ODC VT60, VT80 & VT100
12A2625S03	1	LIQUID INDICATOR, 5/8" SAE VT40
12A2140C01	1	FILTER DRIER CORE VT60, VT80 & VT100
12A2195D28	1	DRIER, FILTER, SPORLAN, VT40
12A2000A07	1	SUCTION ACCUMULATOR, 1-5/8" x 3/4" (After 5/2005)
12A2000A12	1	SUCTION ACCUMULATOR, 2-1/8" x 7/8"

Thawing Gas Line

12A4200A0406	1	SOLENOID VALVE, 1/2" ODC, Normally Closed SPORLAN, 208/230V COIL (Hot Gas valve)
12A4199V53	1	REPAIR KIT FOR 1/2" SPORLAN ME10S2 OR E10S2
12A2105C16	1	COIL, #MKC-2 FOR SPORLAN 208/240V-50/60HZ

Condensing Unit

12A2110A117	1	VT40 – COMPRESSOR	(R22), 3DB3F33K0-TFC-100, 208/230-3-60, 5.5HP
12A2110A130			(R404A), 3DB3F33KE-TFC-100, 208/230-3-60, 5.5HP
12A2110A110	1	VT60 – COMPRESSOR	(R22), 3DS3F46K0-TFC-100, 208/230-3-60, 7HP
12A2110A131			(R404A), 3DS3F46KE-TFC-100, 208/230-3-60, 7HP
12A2110A122	1	VT80 – COMPRESSOR	(R22), 4DL3F63K0-TSK-253, 208/230/400/460, 10HP
12A2110A128			(R404A), 4DL3F63KE-TSK-253, 208/230/400/460, 10HP
12A2110A125	1	VT100 – COMPRESSOR	(R22) 4DT3F76K0-TSK-200, 208/230/400/460, 12.5HP
12A2110A129			(R404A) 4DT3F76K0-TSK-200, 208/230/400/460, 12.5HP
12A7509E12	1	CRANKCASE HEATER, 100 WATT INSERTION Replaces Bolt-on Heater	
12A2117A05	1	SENTRONIC OIL PRESSURE SAFETY CONTROL	
12A2117A0501	1	SENTRONIC OIL PRESSURE SENSOR	
12A4200N0903	1	INLET PRESSURE REGULATOR, 1 1/8" (VT80's & VT100's or VT40 & VT60 split system) Hot gas loop valve	
12A4200A0406	1	SOLENOID VALVE, 1/2" ODC, Normally Closed, SPORLAN, 208/230V COIL (Defrost Loop valve) Split VT40 & VT60	
12A4199V53	1	REPAIR KIT FOR 1/2" SPORLAN ME10S2 OR E10S2	
12A2105C16	1	COIL, #MKC-2 FOR SPORLAN 208/240V-50/60HZ	
12A4200A1104	1	SOLENOID VALVE, 1 5/8" ODC, Normally Open, SPORLAN, 208/230V COIL (Suction Stop valve) VT80 & VT100	
12A4199V47	1	REPAIR KIT FOR 1 5/8" SPORLAN Normally Open valve	

TABLE 8-4
Replacement Parts List

9. Additional Product Information

Power Monitor

Wagner Model #: DTP-3

All Vogt Tube-Ice machine models are available from the factory with a three phase line voltage power monitor with LCD display. The units are also available for after market or retrofit installation. These units monitor line voltage inputs from 190 to 610 volts and provide protection against line voltage variances which can damage or destroy the compressor motor. Features include automatic system shutdown and restart based on current line conditions, a voltmeter, and a non-volatile system memory so settings are retained even if power is lost. If machine is ordered with this option the power monitor can be factory set to customer specifications. The Vogt Part number for a power monitor retrofit kit is 12A7700K01.

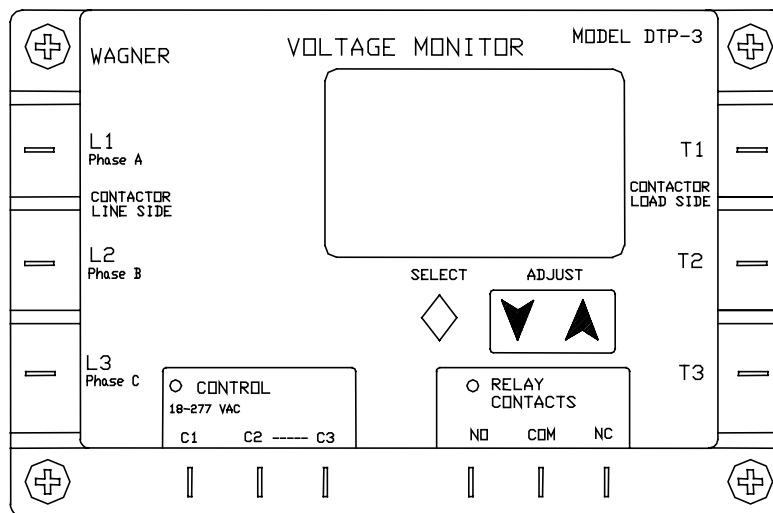

The Display

The display normally shows the AB BC CA line voltages.

If the unit is waiting on a timer, that timer will be displayed. The timer display may be switched off by pressing SELECT. The LCD will then display the normal AB BC CA line voltage pairs.

Pressing the SELECT button once shows the contactor load side voltages (if the load side option is connected). The display automatically returns to the display of line side voltage after a few seconds.

Press the Select button to step through the parameters. As you step through the parameters, the selected parameter will flash. Use the up and down arrow keys to adjust to the desired operating value.

Parameter limits

Parameter	Minimum	Maximum	Default	Recommended Settings	Unit
Line Side Voltage (Nominal Voltage)	90	650	208	Supply voltage	Volts
Over Voltage (tolerance)	6	18	12	10	%
Under Voltage (tolerance)	6	18	12	10	%
Phase Unbalance	2	25	6	5	%
Lockout Time (Delay on Break)	0.1	25	0.5	2	Minutes
Delay Time (Delay on Make)	0	30	0	0	Seconds
Response Time (Delay on Fault)	0.1	20	2	2	Seconds
Contactur Test	OFF	5	OFF	OFF	Volt Diff
Control	Off / Auto / On		Auto	On	N/A

Additional Product Information

Parameters adjustment (in order of display)

Active display of Line Voltage (this is the default normal display)

Active display of Load Side Voltage (if connected)

Voltage Set Point

(VAC Flashes) The value may be adjusted by pressing the up and down arrows. This may be set to the normal operating voltage of the device being protected in one volt increments.

Under/over Voltage Tolerance in %

(UNDERVOLTAGE/OVERVOLTAGE flashes)

The value may be adjusted by pressing the up and down arrows.

Imbalance Voltage Tolerance in %

(% IMBALANCE flashes) The value may be adjusted by pressing the up and down arrows.

Lockout Time in seconds

(SECONDS flashes) The value may be adjusted by pressing the up and down arrows. (This is the delay on break timer value)

Delay time in seconds and tenths of seconds

(RESP. SECONDS flashes) The value may be adjusted by pressing the up and down arrows. This is the time that a fault is allowed before shutdown occurs.

Control mode

(ON OFF AUTO flashes) The value may be adjusted to OFF (load will not turn on), ON (load will turn on whenever there are not faults and timers are finished) and AUTO (Load will turn on when there is a control input).

Contactor fault monitor mode

(CONTACTOR FAULT flashes) This option allows you to monitor the contactor and lock it out if the line voltage and load side varies by more than 5 volts. Pressing the up and down arrows selects off (default) or on. The load side of the contactor must be connected to the load terminals of the DTP-3 to use this option.

Display of fault memories

(MEM flashes) Pressing up or down displays the last fault conditions that took the unit off line. The first 25 faults are recorded. The top number displayed represents the fault memory. The middle number represents the total number of faults that have occurred since the fault memory was cleared.

To clear the memory, press and hold the up and down keys until the display is cleared.

Notes

If you press SELECT and do not change a parameter by pressing the up or down arrow keys, the DTP-3 automatically returns to displaying the line voltage in a few seconds.

The new settings are saved in permanent memory when the display returns to displaying the line voltage. The new settings may be verified by pressing the select button to sequence through the various parameters.

To prevent tripping on a 1 volt change, the DTP-3 automatically calculates cut-in voltages for the return from undervoltage conditions. The cut-out voltage is always based on user voltage and tolerance settings, while the cut-in voltage is 3% closer to the nominal voltage setting. This quality is sometimes referred to as hysteresis. This is to help reduce oscillation that may occur on weak power distribution system. When the load is switched off due to undervoltage, the line voltage will increase. Without the hysteresis, the monitor would switch the load back on, the line voltage would again drop, and cause a continuous on-off-on cycling.

Remote Switch Box

VT Remote Switch Box (Optional)

This small control panel (box) consists of Ice/Off/Clean selector switch, a Manual Harvest/Start button and two indicator lights (power & fault) and can be added to any VT machine. This panel will contain both 208/230VAC and 24VDC.

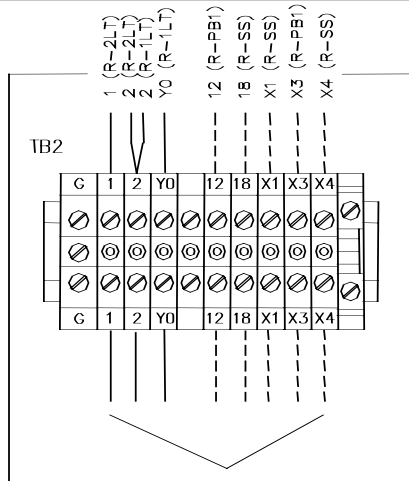
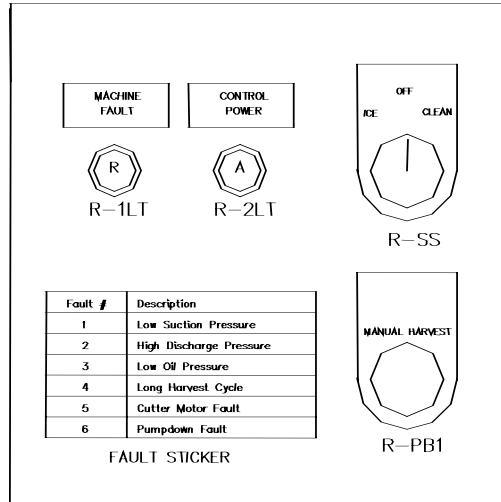

TO LOWSIDE
CONTROL PANEL

----- 16 AWG Blue Wire (24VDC Control Voltage)
 _____ 16 AWG Red Wire (208/240VAC Control Voltage)

Remote Switch Box Parts

R-PB1	12A7500E56	PUSH BUTTON, MOMENTARY, GREEN
	12A7500E75	CONTACT BLOCK, 1 NO, W/MOUNTING LATCH
R-SS	12A7500E81	3 POS. SELECTOR SWITCH OPERATOR
	12A7500E73	CONTACT BLOCK, 2 NO, W/MOUNTING LATCH
R-1LT	12A7520E33	INDICATOR LIGHT, 250V, RED LENSE
R-2LT	12A7520E34	INDICATOR LIGHT, 250V, AMBER LENSE

FIGURE 9-1
Remote Switch Box Layout

Additional Product Information

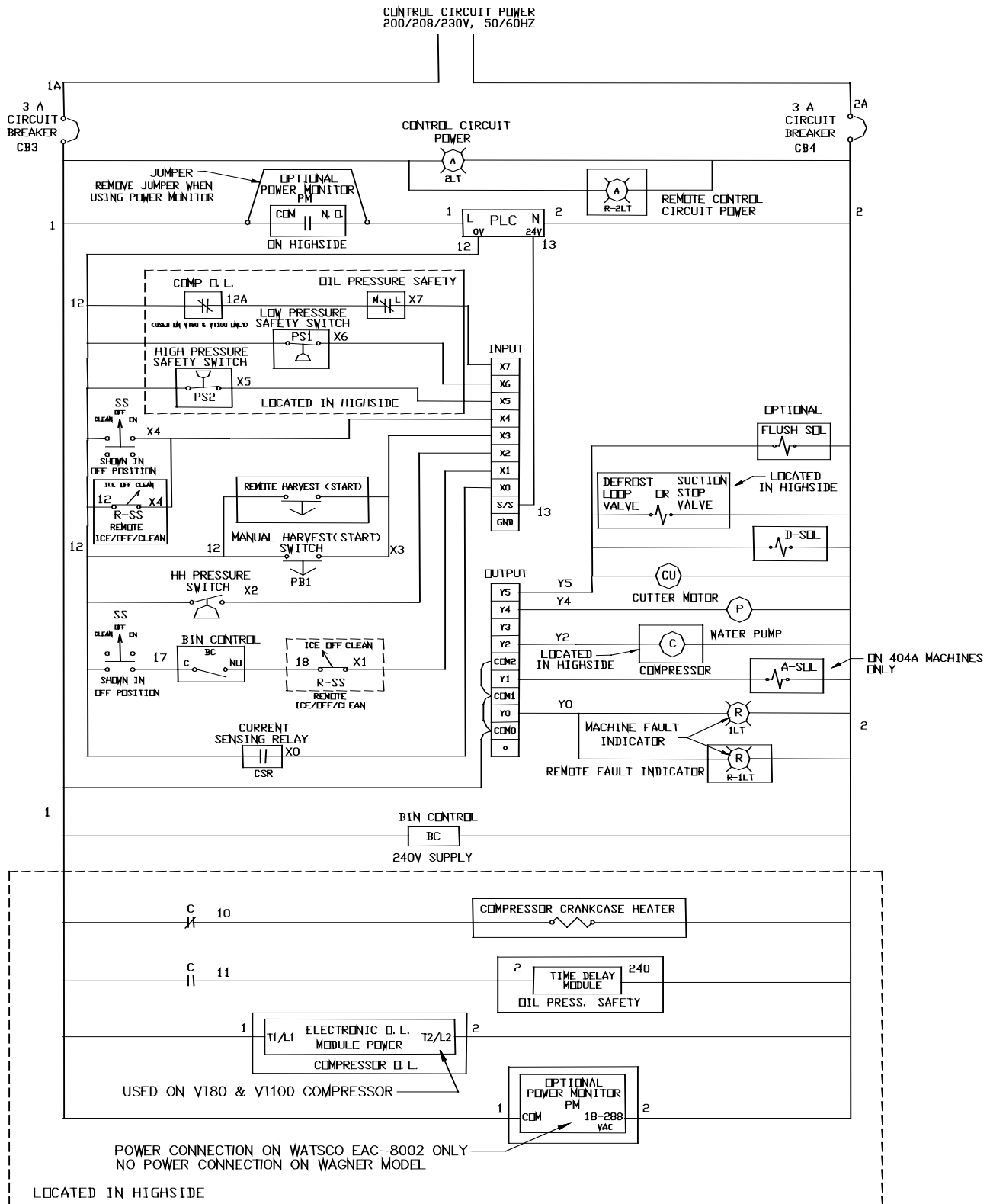

FIGURE 9-2
Complete Electrical Schematic - 208/230V (With Remote Switch Box)

VOGT® VT MACHINE BASIC PRODUCT WARRANTY

Vogt Tube-Ice, LLC. hereinafter referred to as SELLER, warrants every **Vogt® VT Machine Model VT40, VT60, VT80 and VT100** to be free from defects in material and workmanship, if properly installed, maintained and operated under normal use for a period of 24 months from date of original installation or 24 months from date of shipment from SELLER'S plant if the SELLER does not have an accepted start-up form on file. The obligation of the SELLER under this warranty is limited to the repair or replacement of parts or assemblies that in the SELLER'S opinion are defective, F.O.B. the factory.

In addition to the component warranty explained above, the SELLER will pay straight time labor to repair or replace a defective component when failure occurs within 12 months from the date of original installation provided form on file. Such service can only be performed by a SELLER ap that the SELLER does has an accepted start-up proved service representative or a refrigeration service agency as qualified and authorized by the SELLER'S distributor. The date of installation for both the component and labor warranties will be determined by the SELLER from an accepted machine start-up form. To secure prompt and continuing warranty service, the start-up form must be fully completed and sent to the SELLER within thirty (30) days from the installation date. The above labor warranty applies only to the original end user and for machines installed in the **UNITED STATES OF AMERICA** and is not applicable to remote air cooled condensers or ice spreader kits.

The component and labor warranties are not applicable to installation related components such as remote air-cooled condenser lines, bins, external electrical components and external water and drain lines.

Time and hourly rate schedules, as published by the SELLER, apply to all service procedures. Additional expense including, but not limited to, overtime premium, travel time, material cost, accessing of the Tube-Ice® machine, is the responsibility of the owner, along with all maintenance, adjustments, cleaning and ice purchases.

Any alteration in material or design of SELLER'S product or component parts thereof by PURCHASER or others without written authorization by SELLER, problems with the electrical supply, water supply, flood, storm or other acts of God will void all obligations of SELLER regarding the product and any associated warranty herein stated or implied.

SELLER'S sole liability shall be exclusively as set forth herein, and SELLER shall not be liable for any incidental or consequential damages due to its breach of any warranty herein contained, or otherwise. Without limitation to the foregoing, in no event shall SELLER be liable for the loss of the product or for the loss of use of any other product, process, plant, equipment, or facilities of the PURCHASER whether partially or wholly due to

defects in material and/or workmanship and/or design of SELLER'S product, and in no event shall SELLER be liable for removal of appurtenances or

incidentals such as connections, pipework and similar items of obstruction or for any cost brought about by the necessity of removing the product from its point of installation.

SELLER makes no warranty of any kind whatsoever, express or implied, other than as specifically stated herein; and there are no warranties of merchantability and/or fitness for a particular purpose which exceed the obligations and warranties specifically stated herein.

FIVE-YEAR EXTENDED WARRANTY

At the termination of the two year component warranty period above, SELLER hereby extends this warranty for three years to cover **COMPRESSORS**. The five year compressor parts warranty shall not apply when the Vogt® VT Ice machine is installed or modified with a condenser or a heat reclaim device other than those sold by SELLER unless SELLER has accepted modifications for specific installations in writing. *The extended warranty, as it applies to the COMPRESSOR covers only those machines installed in THE UNITED STATES OF AMERICA AND IT'S TERRITORIES.*

TEN-YEAR EXTENDED WARRANTY

At the termination of the two year component warranty period above, SELLER hereby extends this warranty for eight years to cover **EVAPORATOR ASSEMBLIES**. *The extended warranty, as it applies to the EVAPORATOR covers only those machines installed in THE UNITED STATES OF AMERICA AND IT'S TERRITORIES.*

Damage to evaporator tubes as a result of expansion caused by re-freezing of ice, dents or scratches caused by abuse or corrosion damage due to water quality is specifically excluded.

These extensions of warranty and the labor warranty apply only to **VOGT® VT MACHINE MODELS VT-40, VT-60,VT-80 and VT-100** for the exclusive use of the PURCHASER or original end user, as defined above. All other obligations, terms and conditions of the Basic Product Warranty apply to the Extended Warranty.

Vogt® and Tube-Ice® are registered trademarks of Vogt Tube-Ice, LLC, 1000 West Ormsby Ave., Louisville, Kentucky 40210